

PTAX 1-M

Introduction to Mapping for Assessors

April 2023



Printed by the authority of the state of Illinois
PO# 2230316, 15 copies

Table of Contents

Glossary	5
Where to get Assistance	11
Unit 1 Basic Types and Uses of Maps	13
Unit 1 Summary.....	30
Unit 1 Review Questions	31
Unit 2 Measurements and Math for Mapping	33
Unit 2 Summary.....	46
Unit 2 Review Questions	47
Unit 3 The U.S. Rectangular Land Survey	49
Unit 3 Summary.....	60
Unit 3 Review Questions	61
Unit 4 Legal Descriptions	63
Unit 4 Summary.....	90
Unit 4 Review Questions	91
Practice Pages	94
Unit 5 Metes and Bounds Legal Descriptions	97
Unit 5 Summary.....	128
Unit 5 Review	129
Unit 6 Assigning a Property Index Number (PIN)	131
Unit 6 Summary.....	147
Unit 6 Review Questions	148
Unit 7 GIS and Mapping	151
Unit 7 Summary.....	158
Unit 7 Review Questions	159
Examination Information and Prep	160
Course Answer Key	161

Glossary

Acre – A unit of land area in England and the U.S. equal to 43,560 square feet.

Ad Valorem – “According to Value”. Our property tax system is based on assessing property according to value.

Aerial Mosaic - An assembly of aerial photographs to form a continuous photographic representation of a portion of the earth's surface.

Aerial Photograph - Any photograph taken from the air.

Backsight- Surveying sight taken backward; a sight or reading taken by a surveyor back toward a position from which a previous sight has been made.

Base Line, Sectionalized Land - Base line is a parallel of latitude, or approximately a parallel of latitude, running through an arbitrary point chosen as the starting point for all sectionalized land within a given area.

Bearing - Direction of a line measured as the acute angle from a reference meridian usually expressed in the form "S 30° E" or "N 58° W".

Boundary - A line that marks the outermost extent of an area, or a subdivision between areas.

Cadastral map - A map that shows the size, shape and extent of each land parcel in a prescribed geographical area, for purposes of describing and recording ownership.

Call – Specific directions to a point.

Cardinal Directions – The directions North, South, East and West and the directions in-between (Northeast, Northwest, Southeast, Southwest, etc.)

Cartography - The science and art of making maps.

Chain - A land surveyor's measure – 66 feet, or 100 links.

Commencing - Informative term of beginning and/or origin.

Degree - One/360th of the circumference of a circle.

Description - The exact location of a piece of property stated in terms of lot, block, and tract, or by metes and bounds.

Exception – A division of an existing or previously defined area of land, and then excepting out, or removing, an area. The exception can be any exempt area. This type of description always creates a remainder or other area that must be described as well.

Furlong – A unit of measure equal to 1/8 of a mile; 660 feet; 220 yards; 40 rods; or 10 chains.

Geodetic Coordinate – Marks a specific point on the earth's surface.

Geographic Information System (GIS) – A system developed for spatial analysis needs, such as planning, natural resources, and land records management.

Global Positioning System (GPS) – A satellite-based navigation system made up of at least 24 satellites owned and operated by the U.S. government.

Grantee - One to whom a grant is made (buyer).

Grantor - The person by whom a grant is made (seller).

Index Maps - (1) A map of smaller scale on which are depicted the location (with accompanying designations) of specific data, such as larger-scale topographic quadrangles or geodetic control. (2) A map showing the location and numbers of flight strips and photographs, made by assembling individual photographs into their proper relative positions and copying the assembly photographically at a reduced scale.

Latitude - Angular arc distance north or south of the Equator along a meridian of longitude. Latitude lines are horizontal circles around the Earth and measure degrees north or south of the Equator.

Line - Boundary, course, or extension between points; may consist of straight or curvilinear segments.

Link - Linear measurement equivalent to 7.92 inches or .66 feet. A chain is made up of 100 links.

Longitude - Angular arc distance east or west of the Prime Meridian along a parallel of latitude. Vertical circles around the Earth measuring degrees east or west.

Lot and Block – A survey system to locate and identify land, especially in densely populated areas, based on the division of sectionalized land into quarters.

Map - A representation (usually on a flat medium) of all or a portion of the earth, showing the relative size and position of features to some given scale or projection. A map may emphasize, generalize, or omit the representation of certain features to satisfy specific requirements. Maps are frequently categorized and referred to according to the type of information which they are designed primarily to convey, to distinguish them from maps of other types.

Map projection - Involves the transformation of a 3-dimensional form into a 2-dimensional plane; they record the curved surface of the Earth on a flat display. They may be cylindrical, conical or planar. This is the field of cartography.

Meridian Line - A meridian line is any line running due north and south. Since meridian lines converge at the North Pole, no two meridians are parallel. Practically within the limits of a property survey, all lines shown as north, or south are considered parallel.

Metes and Bounds - Precise description of the boundary lines of parcel of land. Not described by reference to a lot or block shown on a map but described by starting at a known point and describing the bearings and distances of the lines forming the boundaries of the property.

Monuments - Monuments are tangible landmarks indicating boundaries.

1. Physical Monument - A physical monument is an existing feature such as a stone or stake but not the line of an adjoining property.
2. Natural Monuments - A natural monument is a naturally occurring object such as a lake, river, tree, boulder, or hill.
3. Artificial Monument - An artificial monument is a man-made object such as a stake, fence, set stone, etc.
4. Record Monument - A record monument is an adjoining property called for in a deed such as a street or a parcel of land.
5. Legal Monument - A legal monument is any monument referenced in a legal description for the purposes of identifying property.

More or Less - The words "more or less" in their ordinary use are to be taken as words of caution, denoting some uncertainty in the mind of one using them and a desire not to misrepresent. When used in connection with quantity and distance, "more or less" are words of safety and precaution, intended merely to cover some slight or unimportant inaccuracy.

Natural Boundary - Any existing boundary that can be readily identified and located, e.g., the boundary line of an adjacent parcel of land, a river boundary, ditch, wall, bluff, etc. Courses and distances, as a rule, give way to a call for a natural boundary, because a natural boundary, if fixed, is unchangeable, and more likely to be the true call than courses and distances.

Parallel Lines - Lines extending in the same direction and at the same distance apart at every point so as never to meet.

Parcel - In land ownership mapping for assessment purposes, a parcel is usually held to be a tract of land under one identical ownership. It may be a combination of two or more tracts acquired by separate deeds.

Patent - A document granting right to land.

Planimetric map - A map representing only the 2-dimensional, horizontal position of features measured on plane surfaces.

Plat Map - Usually a survey drawing of an individual parcel of land showing special characteristics and the locations of any buildings thereon.

Point - "Point" in a boundary is the extremity of a line; spatial location without defined dimensions.

Point of Beginning (POB) - The reference point at the beginning location of a surveyed piece of land.

Point of Commencement (POC) - A remote established point from which the true point of beginning can be identified.

Pole (or rod) – A unit of measure equal to 16.5 feet. Four poles make up a chain.

Political Township - Township units set up by government agencies. They can be changed at any time and do not necessarily correspond with congressional township boundaries.

Prime Meridian (Principal Meridian) - Zero Longitude at Greenwich, England. It is the line from which all other lines of longitude are measured. This includes the line that runs 180° away from Greenwich also known as the International Date Line.

Property Index Number (PIN) - A series of groupings of numbers that describe the geographic location and use of a specific tax parcel.

Public Lands Surveys, or Public Land Survey System (PLSS) - In general, the survey of Federal or State lands or the lands of any other public body. The term, however, is commonly used to designate the cadastral survey of the public lands of the U.S.; originally the Government Land Office (G.L.O.) surveys; the present surveys executed by the Bureau of Land Management (B.L.M.). Synonymous with rectangular surveys of the U.S. lands; or the rectangular survey system.

Quarter Section - A 160-acre block of land, 1/4 of a section.

Range - A vertical column of townships in the rectangular survey system.

Rod (or pole) - A surveyor's lineal measure of 16.5 feet, or 1/4 of a chain.

Scale - Relative ratio of map to ground distances.

Section - A one-mile square block of land containing 640 acres, or one thirty-sixth of a township.

Soil Survey – The systematic description, classification, and mapping of soils in an area. These are published by the USDA and can be used to predict the productivity of soil to grow crops.

Section Number - These are numbers assigned to the one-mile square units within a survey township. A standard survey township will contain 36 sections.

Standard Parallels - Standard parallels, or correction lines, are parallels of latitude at intervals of 24 miles north or south of the base line.

Subdivision - A tract of land divided, by means of a map, into lots, or lots and blocks, for the purpose of resale, generally for residential or agricultural purposes.

Survey - The act or operation of making measurements for determining the relative position of points, on, above, or beneath the earth's surface; also, the results of such operations. Photogrammetric survey - A method of surveying that uses either ground photographs or aerial photographs. Aerial survey - A survey using aerial photographs. Ground survey - A survey made by ground methods. A ground survey may or may not include the use of photographs.

Tax Map - A picture of one or more parcels of land showing the boundaries of subdivisions of land, with the length thereof, and the areas of individual tracts for the purpose of describing and recording ownership. It is a graphical representation on a flat surface of some portion of the earth's surface. It shows the relative size and position of the land with respect to the other properties, roads, highways and major topographic features relating to the value and use of the land.

Topographic map - A map which represents the horizontal and vertical positions of the land features; distinguished from a planimetric map by the addition of relief in measurable form.

Township (congressional township) - Township is a nearly square area of land containing 36 sections.

Traverse - A method of surveying in which a sequence of lengths and directions of lines between points are measured.

U.S. Rectangular Land Survey (Government Survey) - In 1785 the U.S. Congress authorized the first land survey of the United States. It specified that this survey should divide the land into portions approximately 36 miles square. These portions are referred to as townships. The townships are surveyed from an east-west base line and from north-south principal meridians. Townships are laid off from the base lines and meridians. To identify the townships, each is given an identification in which it was referred to by its relation to the base line and meridian. Horizontal tiers of townships are laid off north and south from the base line and numbered consecutively. Vertical columns of townships, called ranges, are laid off to the east and west of the principal meridians and numbered accordingly. The townships can be identified by listing the township tier number and the range number, such as Township 2 North, Range 2 West. Each township is usually divided into 36 sections, each approximately one mile square and containing approximately 360 acres. This may vary considerably at rivers or where base lines or meridians converge, etc., but generally holds true.

Vector Data – A representation of the world using points, lines, and polygons. These data are created by digitizing the base data. They store information in x, y coordinates. Vectors models are used to store data, which have discrete boundaries like county borders, land parcels and roads.

Where to get Assistance

Web Links

- Property Tax Division: <https://tax.illinois.gov/localgovernments/property.html>
- Property Tax Code (35ILCS 200): ilga.gov
- Illinois Property Tax Appeal Board: ptab.illinois.gov/

Publications

- PTAX-1004 The Illinois Property Tax System
<https://tax.illinois.gov/content/dam/soi/en/web/tax/research/publications/documents/localgovernment/ptax-1004.pdf>

Unit 1 Basic Types and Uses of Maps

The purpose of this unit is to provide a basic understanding of the different types of maps and what they are used for. Emphasis will be placed on maps that county officials will commonly work with.

Learning Objectives

After completing the assigned readings, you should be able to

- identify the different types of maps and their functions.
- locate sources for maps.
- understand the limitations of maps.

Terms and Concepts

Aerial Mosaic
Aerial Photograph
Boundary
Cadastral Map
Index Map
Large Scale
Map
Map Scale
Plat Map
Small Scale
Tax Map
Topographic Map

Basic Maps

A map is a two-dimensional representation of the surface of the earth. It depicts spatial relationships between defined features—roads, buildings, mountains, countries, oceans, etc. It has been said that “a picture is worth a thousand words”. If that is true, then a map is worth a thousand pictures. A map can illustrate a vast amount of information, and that information can be very helpful to an assessor.

The basic functions of maps are to provide:







- **Location** - where it is.
- **Identification** - what it is.
- **Inventory** - how is it categorized.

Maps are usually smaller representations of larger areas. To accurately describe the difference in size, a map scale is often used. The scale of the map is the linear measurement on the map described as a ratio to the actual linear physical area of the subject (the Earth, for instance). Sometimes the measuring tool itself is called a scale, vs. a ruler or straight-edge, because the tool has multiple scales indicated on the tool itself, for instance 1:100, 1:200, 1:400, 1:500, 1:600 or even 1:660.

So, a map with a scale of 1” to 100’ means that each 1-inch segment on the map is equal to 100 feet on the ground. This measurement can be abbreviated as 1:100 or 1” = 100’ or 1 inch = 100 ft. One must pay attention to map scale when trying to measure distances. The scale is often indicated on the map legend.

Map Legends

A map legend, or key, is included as part of a map to provide the user with information on the symbols present on the map. The key is often contained in a box or outline near the map corner and could contain information on color-codes, cardinal directions, year of the map, scale and other features. Different types of boundary lines are indicated on the following example:

LAND SURVEY SYSTEMS	
<i>U.S. Public Land Survey System</i>	
Township or range line	
Section Line	
Found section corner; found closing corner	
Witness corner; meander corner	
<i>Other land surveys</i>	
Township or range line	
Section line	

The legend displayed on a GIS map might indicate the Layers of the map.

Small-Scale vs. Large-Scale Maps

Sometimes maps are called **small-scale** or **large-scale maps**. A **small-scale map** represents a small amount of detail over a wide area (or a larger area with less detail). An example would be a map of the state of Illinois.



Small Scale Map = Small detail
Large area

A **large-scale map** represents a large amount of detail over a smaller area with more detail. An example might be a parcel map.

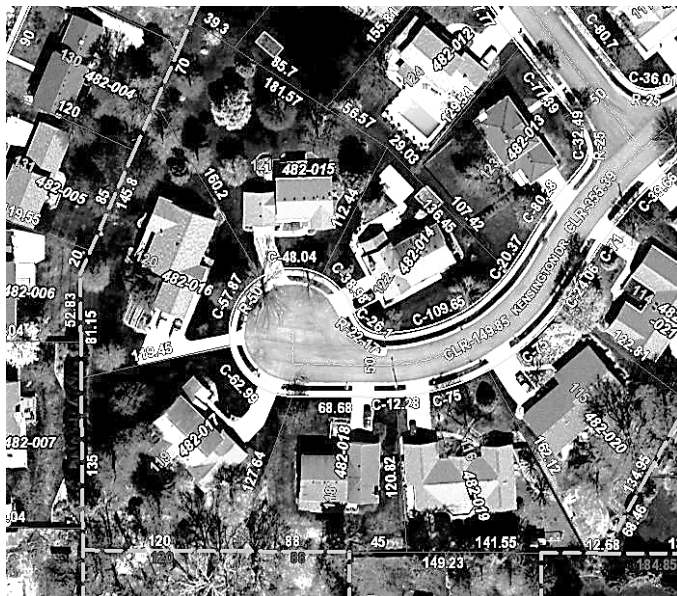

Large Scale Map = Large detail
Small area

No map is completely accurate because it is impossible to accurately represent the curved surface of the Earth on a flat piece of paper. A map of a small area usually has less distortion because there is only a slight curvature of the Earth that affects a small area. A map of a large area, like a map of the world, is significantly distorted because the curvature of the Earth over such a large area is substantial.

How is the Earth's surface like an orange peel? Please refer to the following picture.

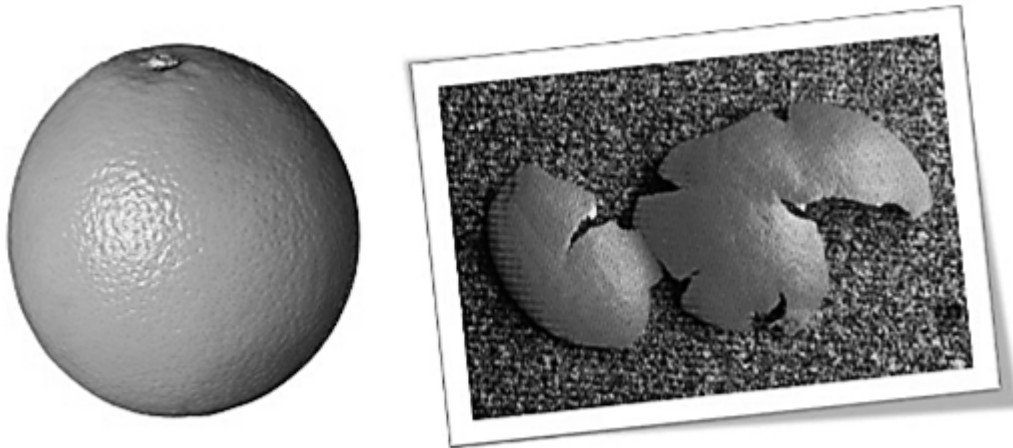

An orange peel demonstrates distortion in maps. If one tries to look at the entire surface on a flat plane, the surface of the orange cannot be completely flattened unless compressed, stretched or torn apart.

Types of Maps

Topographic Maps are usually constructed on a planimetric base, which is a base representing only the 2-dimensional, horizontal positions of features measured on a plane surface, but are distinguished by the fact that changes in elevation (relief) are shown. It represents the horizontal and vertical positions of the land features.

Topographic maps have historically been created by the US Geological Survey (USGS) and are typically available online or from any public library.

Relief, or elevation changes, are represented by contour lines denoting the ground elevation as measured from mean sea level, usually in ten-foot increments.

The following map is a topographic map of a part of Jo Daviess County in northwest Illinois.

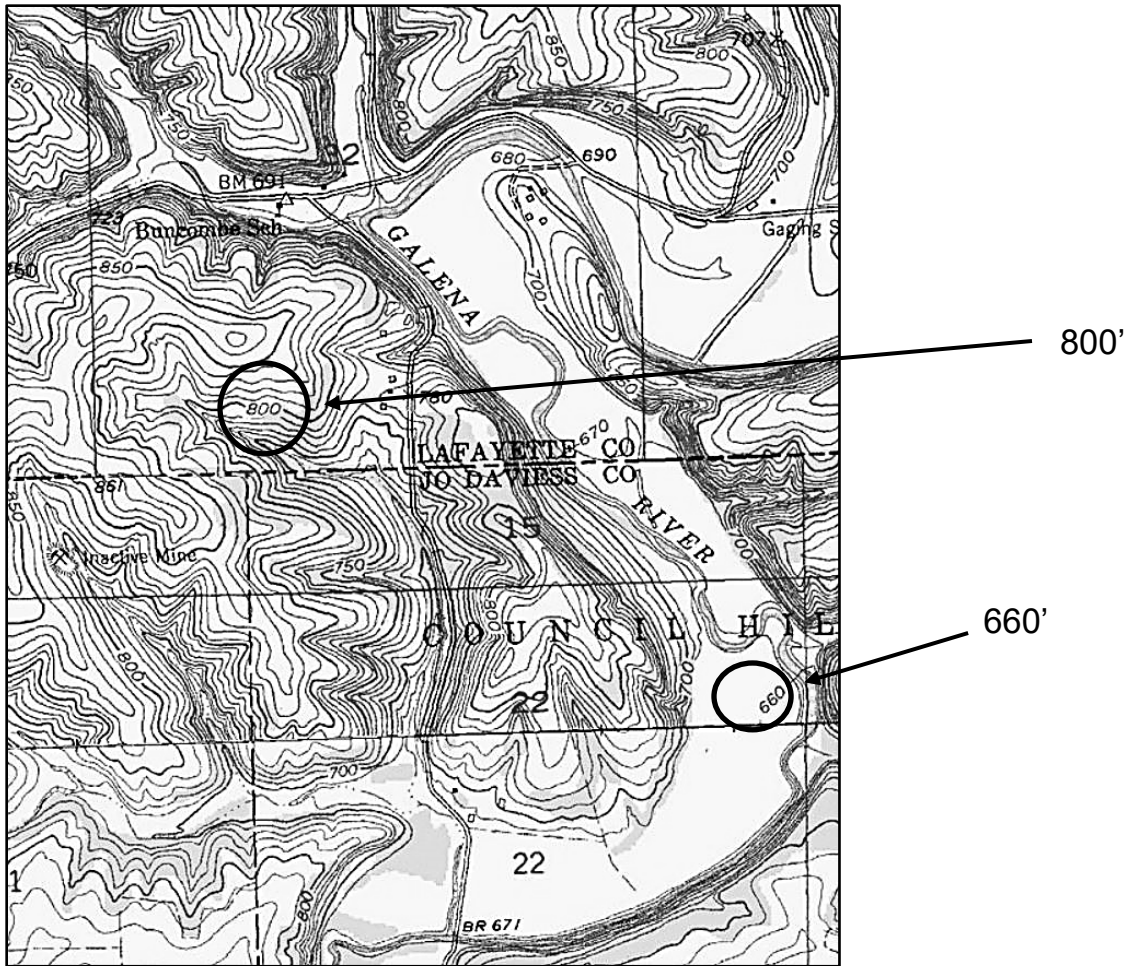

The curvy lines represent changing areas of elevation as measured above sea level. The closer together that the curvy lines are, the steeper the terrain. A county and township overlay have been applied here. As you can see, different elevations are indicated throughout the map. Notice the 660' indicated by the arrow. It lies next to the Galena River. The 800' indicates a much higher elevation.

The highest elevation in Illinois is in Northwest Illinois in the Driftless area. It is located at Charles Mound, and the elevation is 1,235 feet above sea level.

The lowest elevation is at the southernmost city of Illinois at Cairo, with an elevation of 315 feet above sea level.

Highway maps are prepared on virtually every kind of base, but do not generally have highly accurate photographic or planimetric characteristics and are available mostly in small-scale, wide-area formats.

These maps are typically made available through the Illinois Department of Transportation (IDOT) and illustrate all publicly funded roadways (federal, state, county, or township).

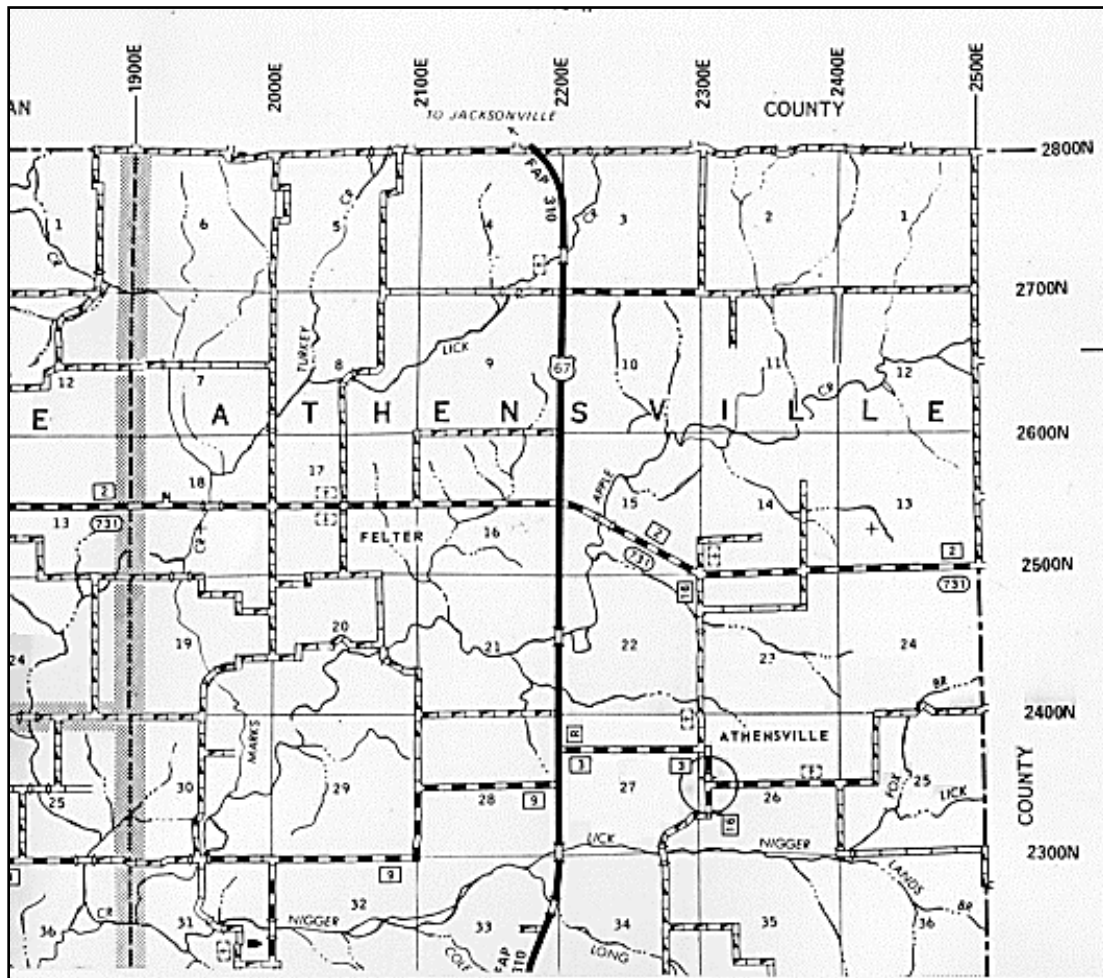

Boundary Maps are usually prepared in combination with one of the previously mentioned types; the key feature being that some type of boundary information is provided. A boundary is “a line that marks the outermost extent of an area”. Examples of boundary maps include maps used for zoning, voting districts, or taxing districts. Most maps used in the assessment process would be of this type.

Illinois District 4 (political boundary)

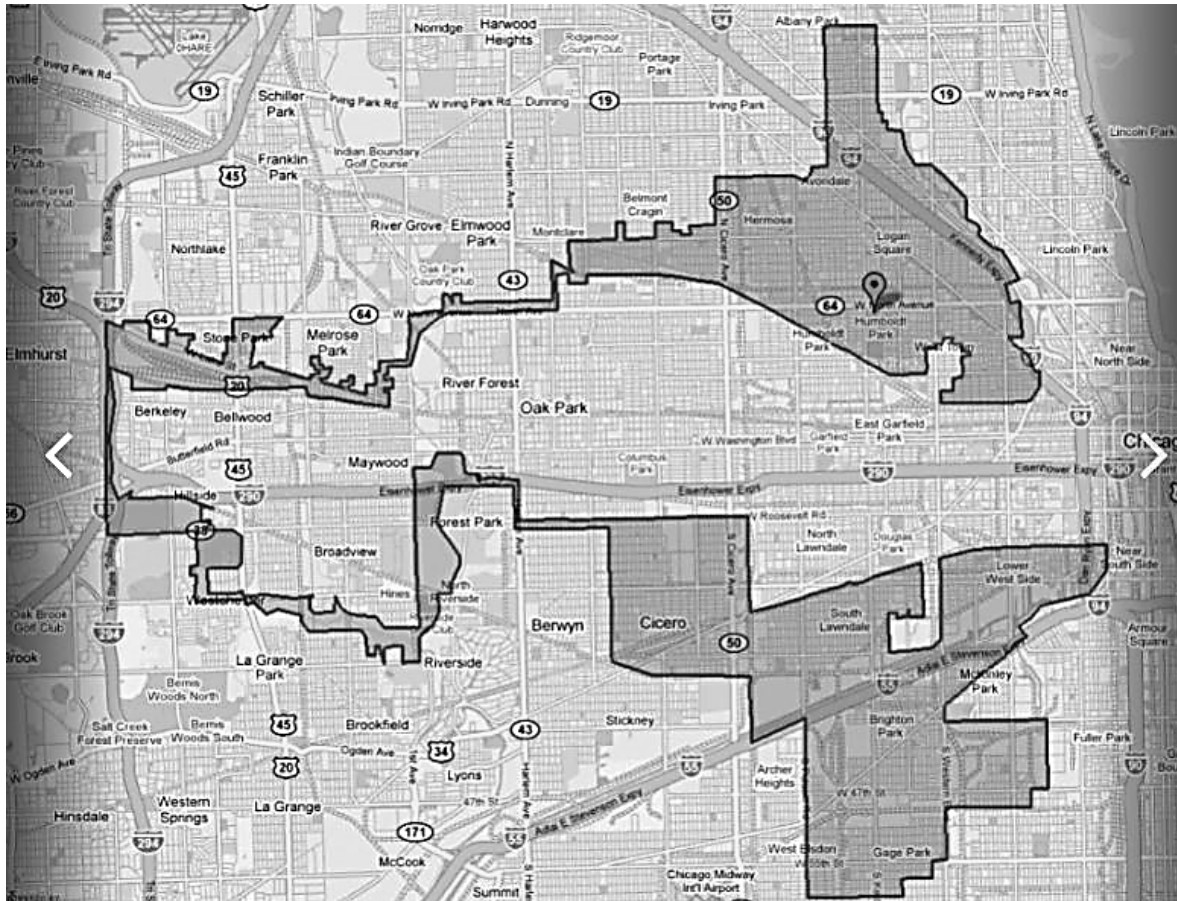

Other types of maps used by the assessor include the:

- **Plat map** - shows property boundaries and ownership.
- **Taxing district map** - shows the boundaries of taxing districts.
- **Cadastral map** - shows the size, shape and extent of each land parcel in a specific geographic area for purposes of describing and recording ownership.

Lake County Cadastral Map

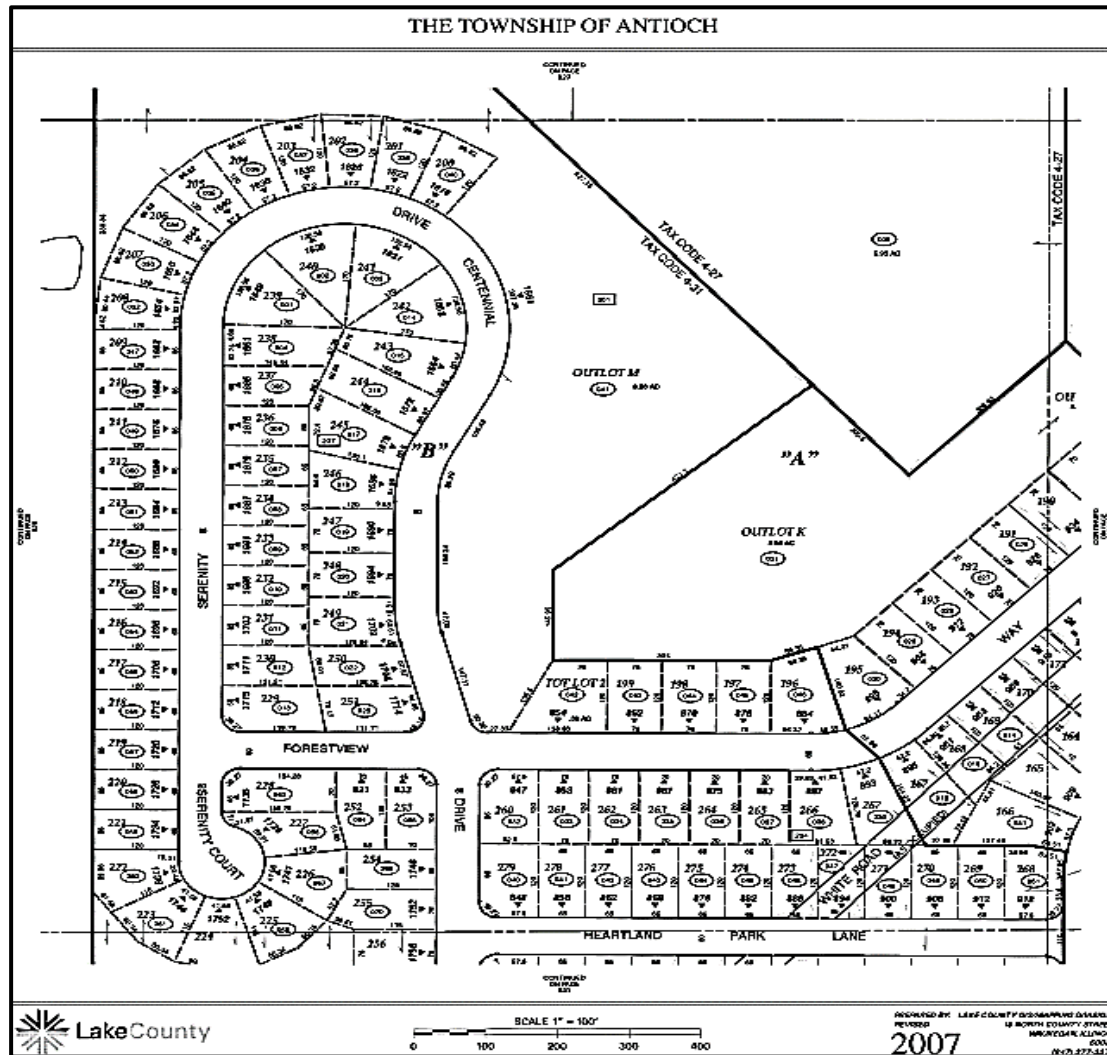

Assessment Maps

Besides the plat, taxing district, and cadastral maps used by the assessor, maps may be known by a variety of names. They may be used interchangeably. The more commonly used terms are:

- appraisal map.
- assessment map.
- property map.
- tax map.

An assessment map has been defined as "a graphic representation of a portion of the Earth's surface, containing graphic descriptions of parcels of land indicating their size and position in relation to other geographic features."

Because a parcel portrayed on a map is the graphic representation of a legal description, the assessment map system must accomplish the following:

1. locate all parcels.
2. identify legal owner.
3. delineate boundaries.
4. inventory improvements.
5. provide administrative data.
6. provide for convenient updating and corrections.
7. provide for easy reproduction.

Maps should be prepared and maintained in such a manner as to give them utility to other offices or agencies. Considering the property tax cycle, assessment maps should be updated at least annually to reflect property changes. The larger the number of users, the more easily justified is the acquisition and maintenance costs of the mapping system.

Assessment maps are **not** substitutes for a legal survey.

GIS Image with Parcel Number and Boundary Layer.

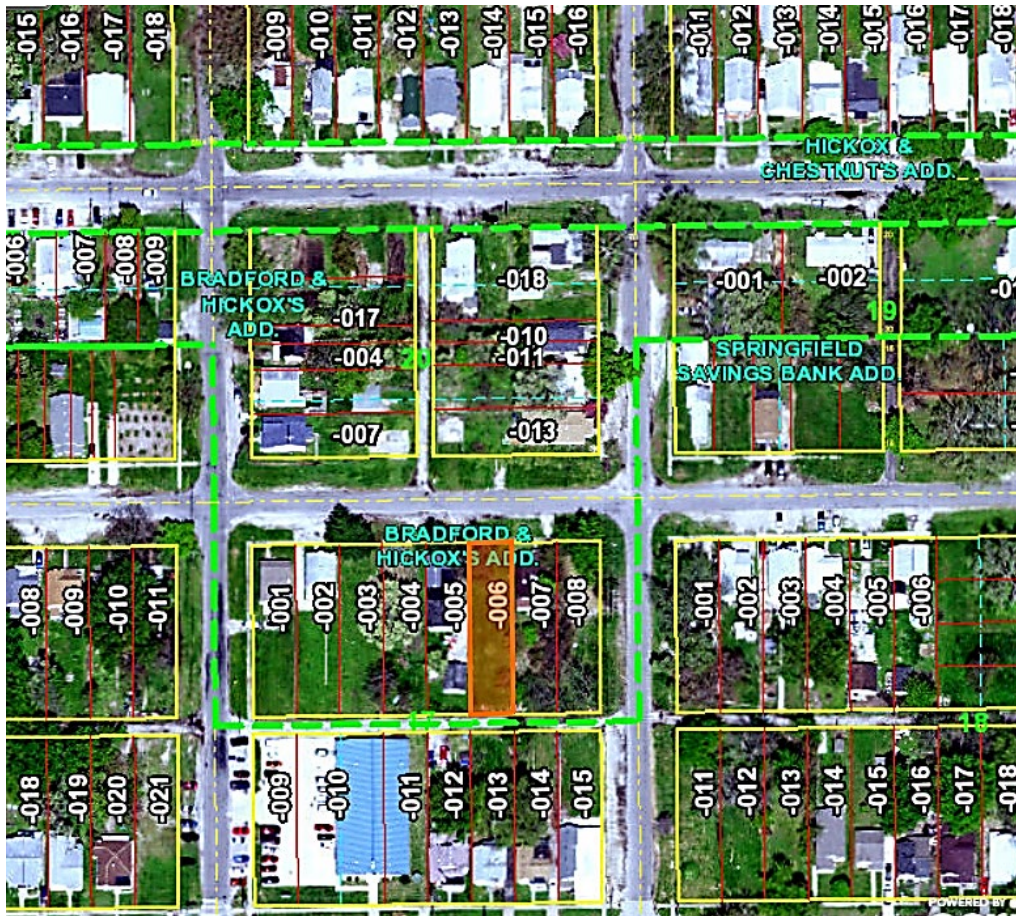

Photographic maps are prepared directly on an aerial photographic base. The information stored varies widely with the use of overlays. The base photo may be black & white, color, or infrared; the size and scale variations are virtually limitless. Photographic maps are generally used for a large-scale small-area coverage. This means that an aerial photograph typically represents a small portion of a county rather than an entire county.

An aerial photograph is any photograph taken from the air. These photographs can be used to create an **aerial mosaic**. An aerial mosaic is an assembly of aerial photographs which form a continuous photographic representation of a portion of the earth's surface. It is somewhat like a patchwork quilt in which pieces of fabric are pieced together to form a quilt.



Aerial Base Tax Maps

A base tax map is prepared using aerial photographs specifically created under controlled conditions. The aerial photographs clearly show all geographical features such as streets, roads, lakes, streams, railroad, and utility lines and provide a visual picture of all property in a jurisdiction. Points of reference (control points) on the ground will have been prominently marked to provide checkpoints on the photography. This photography is used as the foundation for preparing base maps and the features shown will assist with the plotting of parcels. These base maps are the base from which the final tax map is prepared. The aerial photographs should be taken either in early spring or late fall when foliage will not obstruct the view.

There are several types of aerial photographs. Listed below are a few examples.

An Aerial Photographic Enlargement is nothing more than a “blown-up” photograph. Neither tilt nor relief displacement are removed for these photographs. Some newer GIS programs provide oblique 45-degree views that can be used for assessing.



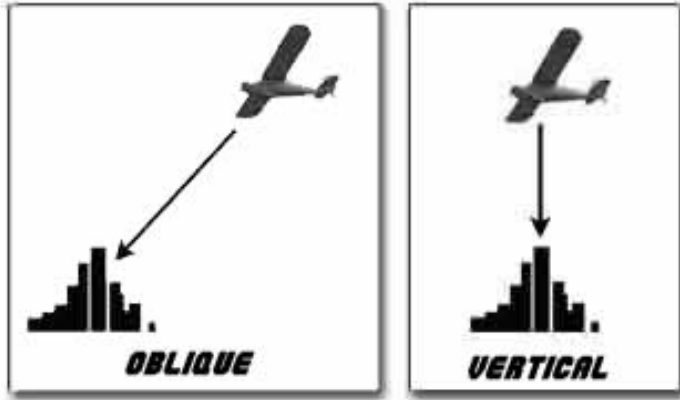

A Rectified Aerial Photograph is one in which distortions caused by tilt (the direction the wings are banked) and yaw (the direction the nose is pointed) of the airplane have been removed. The objective is to project the image back to its correct shape and scale. Although relief displacement is not removed from rectified photographs, this type of photography provides acceptable accuracy for assessment mapping in areas of relatively flat terrain.



An Ortho-photograph is an aerial or satellite image that has the accuracy of a map drawn from ground survey information because tilt and relief displacement have been eliminated. Measurements of a land surveyor on the ground should "fit" when plotted on a true-to-scale ortho-photograph. Distances and area calculations on ortho-photographs are usually extremely accurate, and property lines will correspond closely to physical features.



Recommended map scales for aerial photographs are:

- 1" = 100'** for urban maps (1 inch on the map is equal to 100 feet on the ground).
- 1" = 400'** for rural maps (1 inch on the map is equal to 400 feet on the ground).

Other examples of Ortho-photographs



Dewitt County



LaSalle County



DuPage County

Soil Survey Maps

A soil survey describes the characteristics of the soils in each area, classifies the soils according to a standard system, plots the boundaries of the soil types on a map, and makes predictions about the behavior of soils. The different uses of the soils and how the response of management affects them are considered.

Soil survey maps were first used by the Romans! But it wasn't until 1896 that soil surveys were first authorized in the United States. By the end of the nineteenth century the knowledge about soils that had been gained from farming, agricultural chemistry, biology, and geology grew into a unified concept of the soil itself. Starting with Assessment Year 2006, farmland assessment in Illinois is based on Bulletin 810 (Average Crop, Pasture, and Forestry Productivity Ratings for Illinois Soils) from the University of Illinois College of Agriculture.

Different kinds of soil have interrelated properties that define the characteristics of the soil. These different properties are used to form generalized soil boundaries that are displayed on a soil map. Modern detailed soil mapping prepared by the Illinois Cooperative Soil Survey (ICSS) is now available for every county. These maps provide a detailed inventory of soil types found in a specific area. They also indicate the slope, erosion, and soil type location. The various soil types are delineated on the soil map and are numerically coded for identification. The ICSS soil maps contain the level of accuracy needed to ensure that soil productivity indexes are accurate.

To be eligible for a farmland assessment, property must have been solely used as a farm for the prior two years and not be part of a primarily residential parcel. Further, all land use assignments for the property must be in compliance with the Bureau of Census definitions and IDOR guidelines: for example, cropland, permanent pasture, other farmland, wasteland and home site acreage.

To determine the value of farmland requires the combination of land use, acreage of each soil type, slope and erosion debasement factors, flood debasement factors and debasements due to drainage district assessments.

Erosion is an estimate of the maximum average annual rate of soil erosion by wind or water that can occur over a sustained period without affecting crop productivity. The higher the value, the more susceptible the soil is to sheet and rill erosion by water.

- 1 = Un-eroded
- 2 = Moderately Eroded
- 3 = Severely Eroded

The first set of numbers on the soil survey represent the type of soil. The letter following the number indicates the percent of slope. A number following the letter indicates the amount of erosion.

A soil identified as 171 B2 on a soil map would indicate the following.

- 171 = soil type (Catlin silt loam)
- B = a slope of 2% to 4%
- 2 = moderate erosion

Unit 1 Summary

A map is the 2-dimensional representation of a portion of the earth's surface.

The basic functions of maps are to provide location, identification, and inventory.

A large-scale map shows a large amount of detail of a smaller or more limited area.

A small-scale map shows a small amount of detail on a large area.

A map legend is a key used to provide the user with information on symbols and features present on a map.

Some types of maps are:

- Topographic
- Photographic
 - Aerial Base Tax Map
 - Aerial Mosaic
 - Enlargement
 - Rectified
 - Ortho-rectified
- Highway
- Boundary
- Soil
- Assessment, Tax or Cadastral
- GIS

A map that shows the size, shape and extent of each land parcel in a prescribed geographical area for purposes of describing and recording ownership is called a tax (assessment) map or a cadastral map. These maps should be updated annually.

A map which represents the horizontal and vertical positions of the land features and shows the relief in a measurable form is a topographic map.

An aerial mosaic is an assembly of aerial photographs forming a continuous photographic representation of a portion of the earth's surface.

A soil survey provides information concerning soil type, slope, erosion and soil location information. Soil type is a group of soils having horizons similar in characteristics and arrangement in the soil profile and developed from a parent material.

Maps are available in different sizes and degrees of detail. A map taken from the air is called an aerial photograph. Aerial photographs are available at different scales which affect the degree of detail provided. The recommended map scale for aerial photograph is: 1" = 100' for urban maps and 1" = 400' for rural maps. Assessment maps should be updated every year.

Unit 1 Review Questions

1. What is an aerial mosaic map? _____

_____.

2. What is a topographic map? _____

_____.

3. What is a cadastral map? _____

_____.

4. What is the recommended scale for an urban aerial-based tax map?

5. What is the recommended scale for a rural aerial-based tax map?

6. What are the basic functions of maps?

1. _____

2. _____

3. _____

7. A Soil Survey Map has 3 sets of alphanumeric characters which indicate what features of the soil (in order):

Unit 2 Measurements and Math for Mapping

Learning Objectives

After completing the assigned readings, you should be able to

- calculate area for a square, rectangle, or triangle.
- recognize older units of measurement.
- calculate area for complex shapes.

Terms and Concepts

Chain
Parcel
Rod
Link
Acre

History of Measurements

Our measurement system, which has been evolving since the time of the Egyptians, came to us by the way of the English. Here, according to National Geographic, is how some of the measuring units began.

King Edgar's Thumb and Charlemagne's Foot

(Note: You will not be responsible for the following nine definitions on your exam.)

Barleycorn – The length of a grain of barley. Three barleycorns equal one inch.

Inch – The width across the knuckle on King Edgar's thumb, or 3 barleycorns.

Foot – The length of Charlemagne's foot, modified in 1305 to be 36 barleycorns laid end to end.

Cubit – The length of the arm from elbow to fingertip.

Yard – The reach of King Henry I's nose to his fingertips, a distance twice as long as a cubit.

Fathom – The span of a seaman's outstretched arms; 880 fathoms make a mile.

Furlong – The length of a furrow a team of oxen could plow before resting

Mile – 1,000 double steps of a Roman legionary. Later Queen Bess added more feet so a mile would equal 8 furlongs.

Acre – The amount of land a yoke of oxen could plow in one day.

Land Measurement

As the value of land often depends on its area (square foot), it is essential that the utmost care be taken when calculating acreage. The area of most odd shaped tracts will have to be calculated by dividing the tract into rectangles and triangles or portions of circles. Historically, tools used by surveyors dictated the units of measure for property descriptions. Even though modern technology provides more precise measurements, there are still thousands of legal descriptions filed at county offices that use these surveyor units.

1 chain	=	66 feet or 100 links
1 link	=	.66 ft. = 7.92 inches
1 rod (or pole)	=	16.5 feet (4 rods = 1 chain)
1 acre	=	43,560 square feet
1 furlong	=	660 ft.
1 barleycorn	=	1/3 inch (3 barleycorns = 1 inch)

Using and Converting Units of Measure

If a legal description says “from the point of beginning, travel 12 chains, 3 rods and 6 links to ...” the calculation of distance would be as follows:

1 chain = 66 feet	66 feet x 12 =	792 feet
1 rod = 16.5 feet	16.5 feet x 3 =	49.5 feet
1 link = .66 feet	.66 feet x 6 =	<u>3.96 feet</u>
Total distance traveled would be		845.46 feet

Always convert to feet before you do the calculation!

Measuring Parcel Area

Square/Rectangle Area = Length x Width

If the length of a rectangle is 100 feet, and the width of the rectangle is 50, by multiplying 100 x 50, the area of the rectangle would be 5,000 square feet.

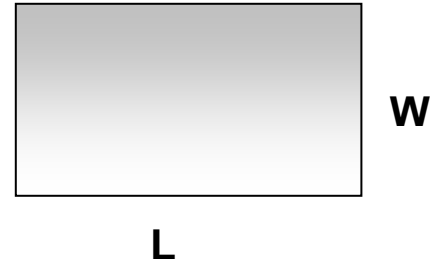

Right Triangle Area = $\frac{\text{Base} \times \text{height}}{2}$

For right triangles, calculating the area is identical to that of calculating the area of a rectangle, **except the area is divided in half** because a right triangle is half of a rectangle.

If the base of the triangle is 75 feet and the height is 150, multiply 75 x 150, the area of a **rectangle** would be 11,250 square feet. Divide this area by 2 would give an area of 5,625 square feet for the right triangle.

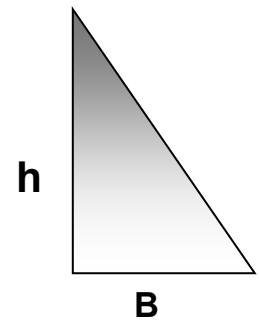

Circle Area = $\pi \times \text{radius}^2$ (Pi R Squared)

[$\pi \approx 3.1416$]

Note: For the purposes of this class, parcels containing portions of a circle will not be used. However, it should be noted that the area of a circle may be needed when calculating parcels located on cul-de-sacs.

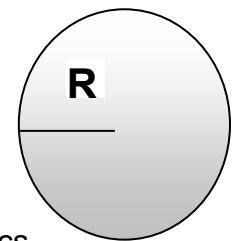

The radius of a circle is the distance from the center of a circle to the periphery or outside of the circle. If the radius of the circle is 25 feet, by taking 25 X 25, the radius squared = 625. Multiplying 625 by 3.1416, the area of the circle is equal to 1,963.5 square feet.

Acreage

Once the square footage for a parcel has been determined, the acreage can be determined by dividing the square footage of the parcel by 43,560, the number of square feet in an acre.

$$\text{Acreage} = \frac{\text{Square feet}}{43,560}$$

The rectangle, which contained 5,000 square feet, would equal .1148 of an acre.

$$5,000 \div 43,560 = .1148 \text{ or } .11 \text{ rounded}$$

The right triangle, which contained 5,625 square feet, would equal .1291 of an acre.

$$5,625 \div 43,560 = .1291 \text{ or } .13 \text{ rounded}$$

The circle, which contained 1,963.5 square feet, would equal .0451 of an acre.

$$1,963.5 \div 43,560 = .0451 \text{ or } .05 \text{ rounded}$$

Exercise 2-1 Land Measurement

Compute the square footage and the acreage for the following (assume all triangles are right triangles). Note: "ch." refers to chains, "rds." refers to "rods", and "lks." refers to links. When calculating some of the parcels, **it will first be necessary to convert the measurements to linear feet. Carry out answer to two decimal places. When rounding, 5 and over, round up. Under 5, round down.**

<u>Parcel shape</u>	<u>Measurements</u>	<u>Square Footage</u>	<u>Acreage</u>
1. Square	1,528 ft. x 1,528 ft.	_____	_____
2. Square	680 ft. each side	_____	_____
3. Rectangle	1,250 ft. x 1,000 ft.	_____	_____
4. Rectangle	125 ft. x 75 ft.	_____	_____
5. Square	65 ch. x 65 ch.	_____	_____
6. Rectangle	30 ch. x 48 ch.	_____	_____
7. Triangle	475 ft. x 986 ft.	_____	_____
8. Triangle	680 ft. x 360 ft.	_____	_____
9. Triangle	22 ch. x 48 ch.	_____	_____
10. Triangle	38 ch. x 46 ch.	_____	_____
11. Square	5 rds. x 5 rds.	_____	_____
12. Rectangle	5 rds. x 7 rds.	_____	_____
13. Rectangle	200 lks. x 300 lks.	_____	_____
14. Square	(8 chains, 3 rods, 16 links)	_____	_____
Note: Each side is 8 chains + 3 rods + 16 links			

1 chain	= 66 feet
1 link	= .66 ft. (7.92 inches)
1 rod (or pole)	= 16.5 feet
1 acre	= 43,560 sq. ft.
Acreage	= # <u>Square feet</u> 43,560

Measuring Irregular Rectangular Parcels

Example 1

By breaking down parcels into shapes we can measure easily, we can measure squares and rectangular shapes that define a property.

For instance, let's look at the shape **A** below.

At first glance, it may not be apparent that there are at least three ways to approach measuring this parcel.

The first step is to determine the dimensions.

Notice that every measurement is not included on the diagram. It is assumed that the assessor can "fill in the blanks" if all the dimensions are not shown.

Recall that the opposite sides of a rectangle have the same measure. For instance, if the length of the northernmost line is 100', and the length of the southernmost line is 40', it can be deduced that the length of the remaining east-west line is 60' ($100' - 40' = 60'$)

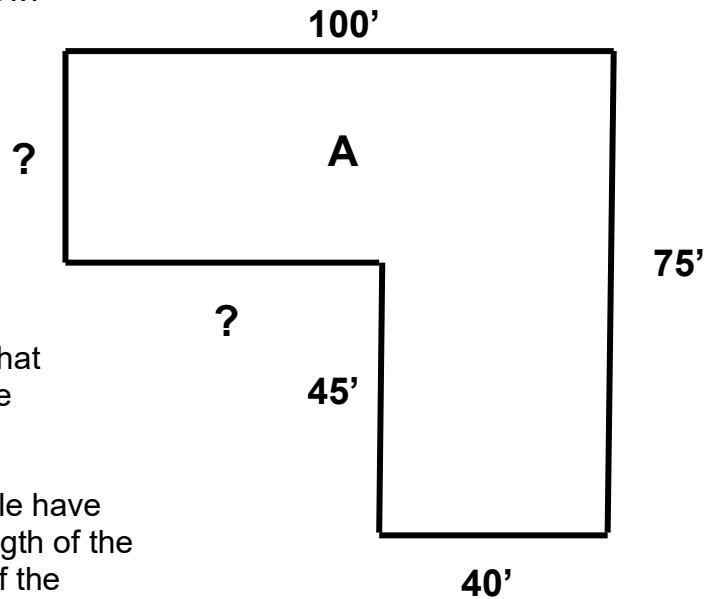

This shape could be measured in a few different ways. You might select the way that you visualize most easily or the method which uses the fewest number of calculations.

We will look at three different ways to measure this shape and find the correct number of square feet.

The shape could be divided into the shapes **A** & **B**.

$$A = 60' \times 30' = 1,800 \text{ SF}$$

$$B = 75' \times 40' = 3,000 \text{ SF}$$

$$1800 \text{ SF} + 3,000 \text{ SF} = 4,800 \text{ SF}$$

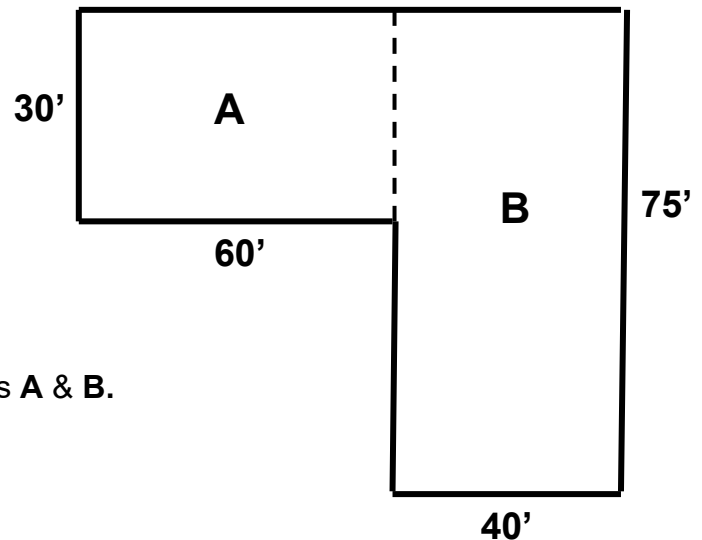

Another way to measure this parcel is to divide it into two rectangles this way.

The measurements would be:

$$A = 100 \times 30 = 3,000\text{SF}$$

$$B = 40 \times 45 = 1,800 \text{ SF}$$

$$3,000 \text{ SF} + 1,800 \text{ SF} = 4,800 \text{ SF}$$

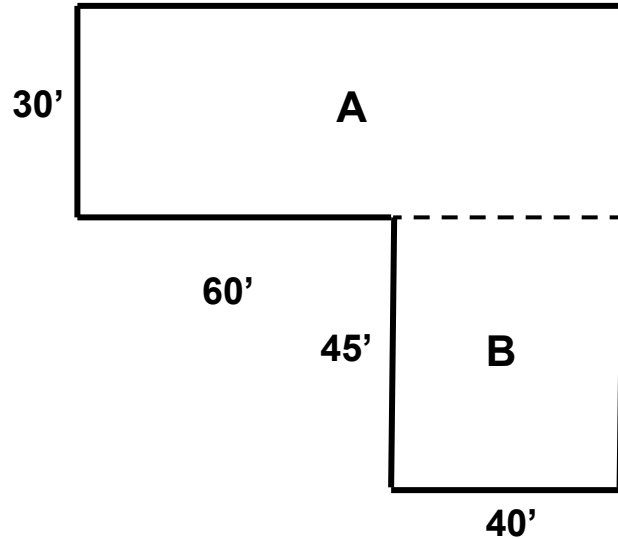

Finally, yet another way to measure this parcel could be subtractive. Measure the imaginary outline of the entire rectangle and subtract the part that is “missing”.

The measurements would be:

$$A = 75' \times 100' = 7,500 \text{ SF}$$

$$B = 60' \times 45' = 2,700 \text{ SF}$$

$$7,500 \text{ SF} - 2,700 \text{ SF} = 4,800 \text{ SF}$$

Notice that all 3 methods produce The same result of 4,800 SF.

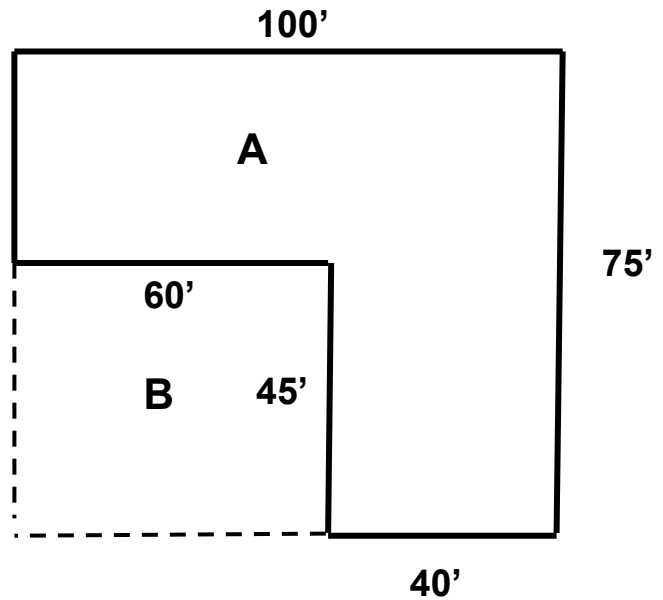

To find the number of acres in this parcel, divide the number of square feet by the number of SF in an acre (43,560).

$$\frac{4,800 \text{ SF}}{43,560 \text{ SF}} = .1102 \text{ Acres}$$

Measuring Irregular Parcels with Triangular Shapes

By breaking down parcels into series of rectangles and triangles and using the measurements provided, you would be able to calculate the area of almost any parcel.

Example 2

In this example, the parcel is drawn with the outer boundary measurements provided

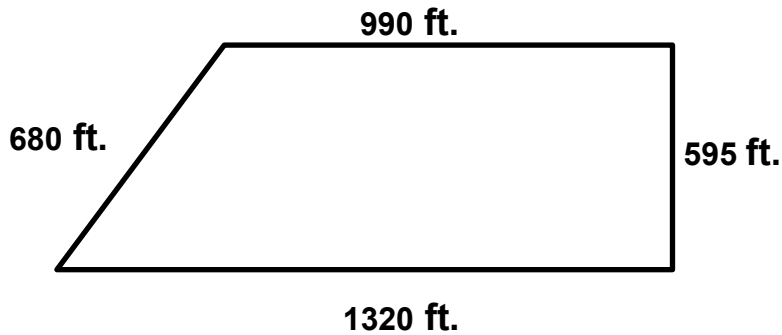

Step 1 Create a rectangle.

A **Right Triangle** (90°) can be created (**Triangle A**) leaving **Rectangle B**.

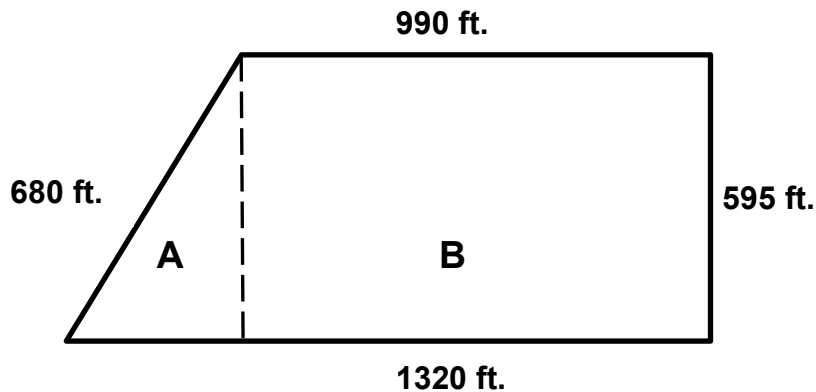

Step 2 In this example, the area of **Rectangle B** can be calculated using known values of 990 feet for the length and 595 feet for the width.

Area of the rectangle = **990 feet x 595 feet = 589,050 square feet.**

$$\text{Area} = \text{L} \times \text{W}$$

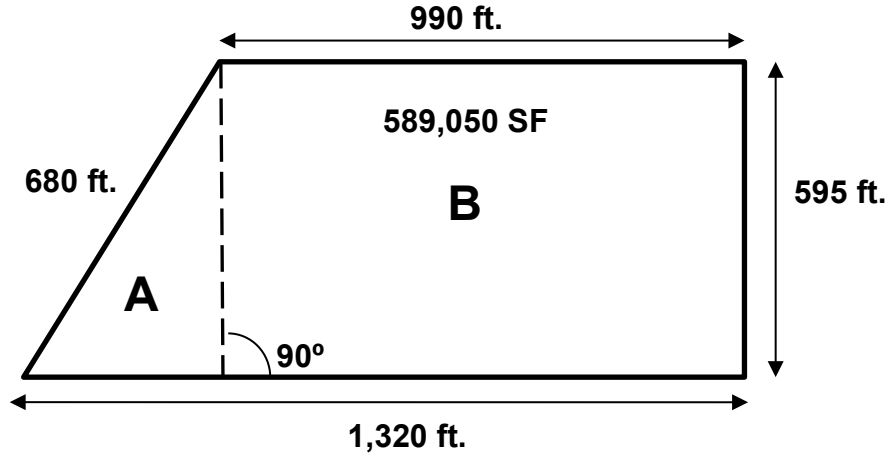

Step 3 The remaining area of the parcel is that of **Right Triangle A**. However, looking at the triangle, there do not appear to be any usable values. This is a good opportunity to point out a very important note. The hypotenuse of the triangle (the long side of the triangle, in this example the line labeled as 680 ft.) is not used in calculating the area of a triangle. The area of a right triangle is calculated by multiplying the base times the height and dividing the product by two. The hypotenuse (long side) is never used.

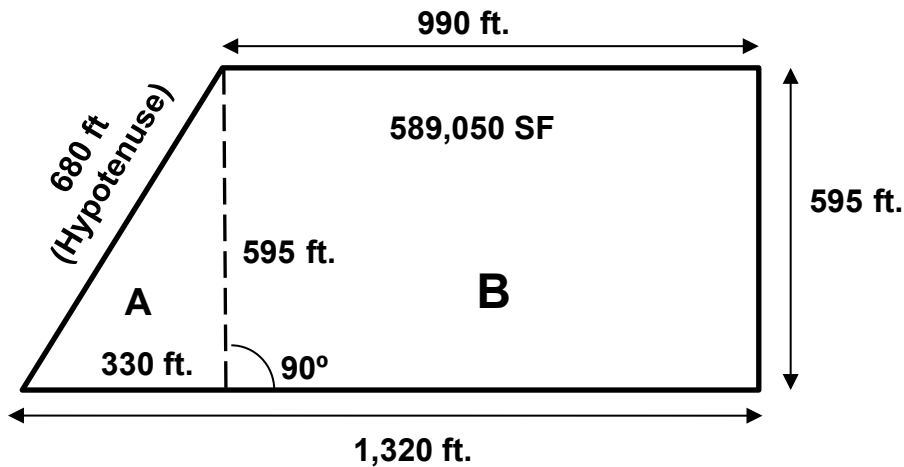

In this example, the base and height values must be determined from the other measurements provided. As a result, the height of **Right Triangle A** is the height of **Rectangle B** (595 feet). For the base of the triangle, that value can be determined from the existing values as well. The base of **Rectangle B** is 990 feet. Considering the entire length of the bottom of the parcel is 1,320 feet and knowing that **Triangle A** is a right triangle, then the base of **Right Triangle A** is 1,320 feet minus 990 feet, or 330 feet.

Therefore, the area of **Right Triangle A** is:

$$\frac{595 \text{ ft.} \times 330 \text{ ft.}}{2} = 98,175 \text{ square feet.}$$

Step 4 Calculate the total acreage of the parcel. By taking the square footage of **Right Triangle A**, which equals 98,175, and adding the square footage of **Rectangle B**, which equals 589,050, we arrive at a total of 687,225 SF for the parcel. By dividing the total area of the parcel (687,225 SF by 43,560 SF) we arrive at a total of **15.78** acres for the parcel.

$$589,050 \text{ SF} + 98,175 \text{ SF} = \frac{687,225 \text{ SF}}{43,560 \text{ SF}} = 15.78 \text{ AC}$$

Example 3

Find the area (in square feet and acres) of the figure below.

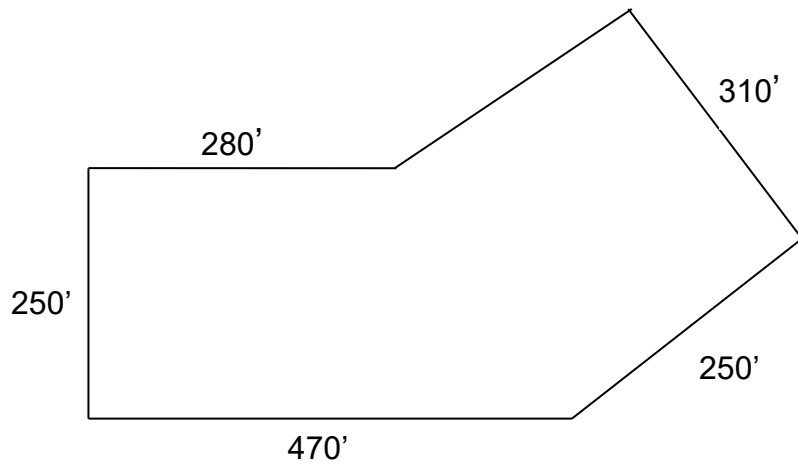

First divide the figure into rectangles and right triangles.

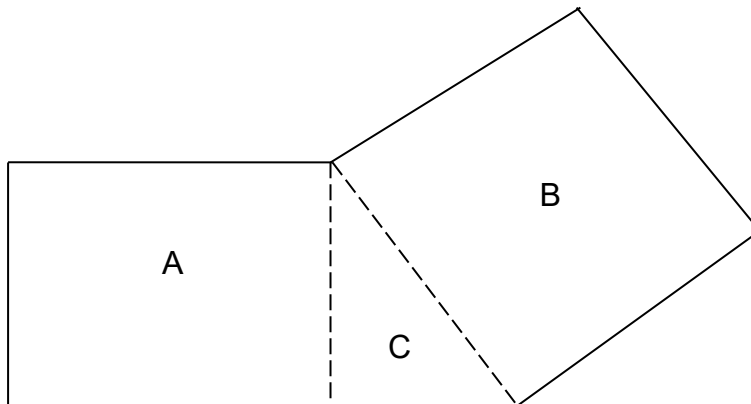

Remember that the opposite sides of rectangles have the same measure. The base of the triangle is found by subtracting the length of the side of the rectangle from the length of the whole side.

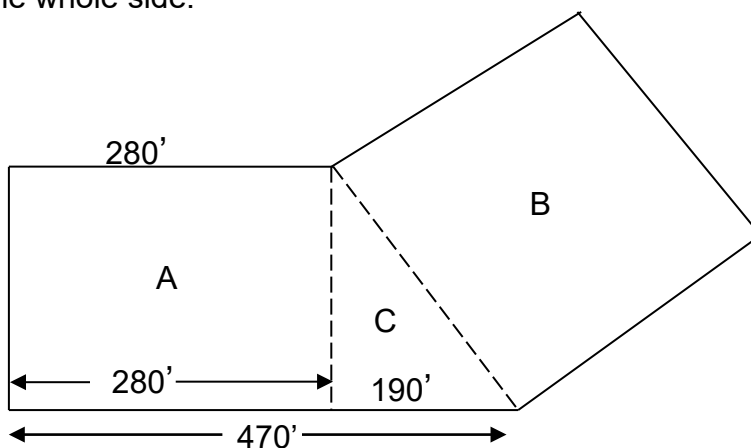

$$470' - 280' = 190'$$

The area of rectangle **A** = $280' \times 250' = 70,000 \text{ SF}$. The area of the triangle C can be determined with the formula for finding the area of a triangle $\frac{(B \times h)}{2}$.

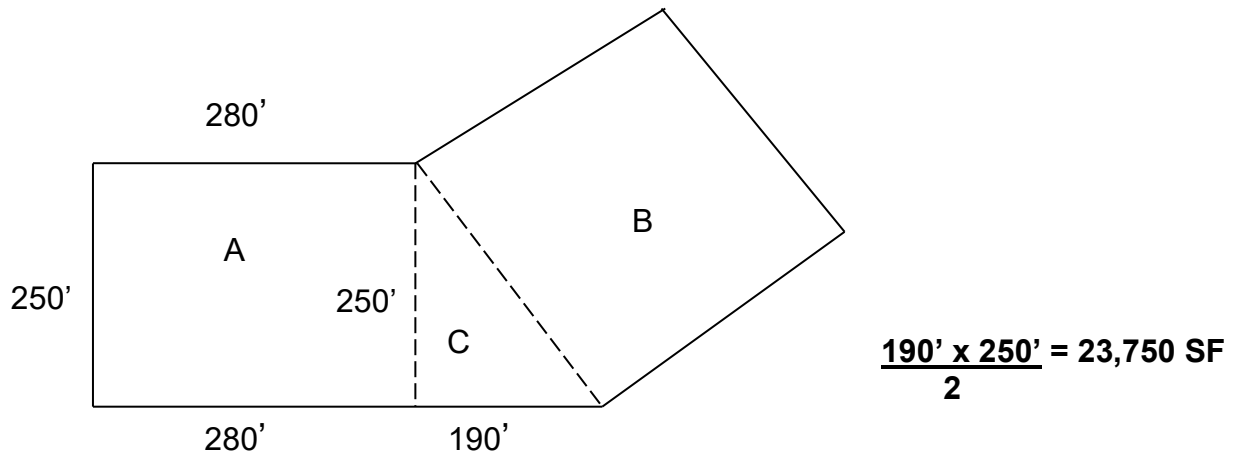

Now the area of rectangle B can be determined again using the mathematical fact that opposite sides of a rectangle have the same measure.

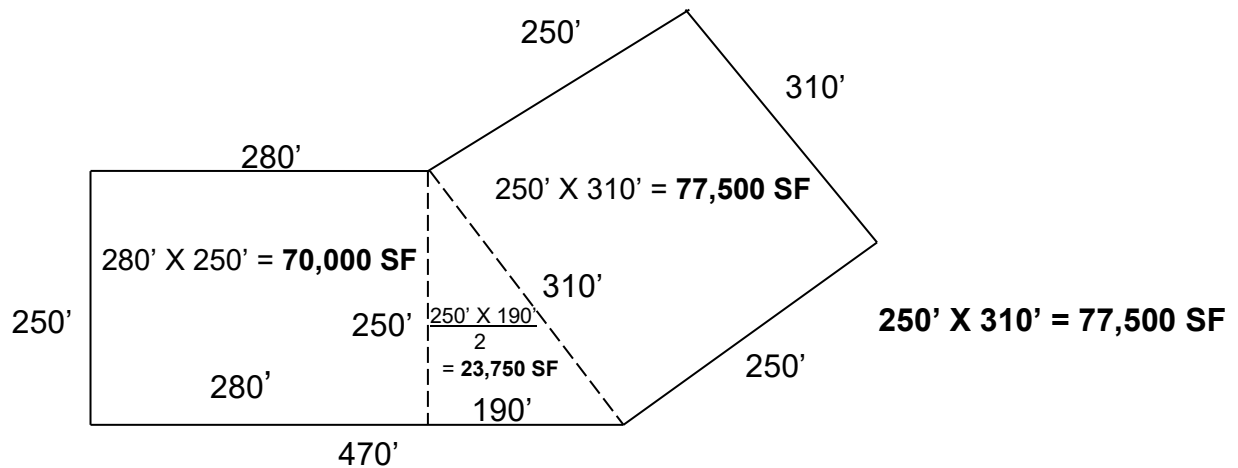

Finally, add **A + B + C** = $70,000 \text{ SF} + 23,750 \text{ SF} + 77,500 \text{ SF} = 171,250 \text{ SF}$

$$\text{Acreage} = \frac{171,250 \text{ SF}}{43,560 \text{ SF}} = 3.93 \text{ acres}$$

Unit 2 Summary

Legal descriptions are often written using various units of measure. The descriptions often describe tracts of land in various shapes. While modern surveys for legal descriptions use common terms of feet or inches, dimensions on older surveys were often given in chains, rods, or links.

$L \times W = \text{Area of a Rectangle}$

$\frac{L \times W}{2} = \text{Area of a Triangle}$

Also, all legal descriptions are not square or even regularly shaped. It is often necessary to convert to common units of measurement or to apply simple geometry to calculate acreage.

1 chain	= 66 feet
1 link	= .66 ft. (7.92 inches)
1 rod (or pole)	= 16.5 feet
1 acre	= 43,560 sq. ft.
Acreage	= # <u>Square feet</u> 43,560

Convert all measurements to feet before calculating areas.

Once the square footage of a parcel has been calculated, the acreage can then be determined by dividing the square footage by 43,560 square feet.

Round measurements to the nearest inch or to 2 decimal points. 5 and over, round up- under 5, round down.

Unit 2 Review Questions

Carry out the SF to closest whole number. Carry out acreage to two decimal places.

<u>Parcel shape</u>	<u>Measurements</u>	<u>Square Footage</u>	<u>Acreage</u>
1. Square	1,742 ft. x 1,742 ft.	_____	_____
2. Rectangle	165 ft. x 95 ft.	_____	_____
3. Square	82 ch. x 82 ch.	_____	_____
4. Triangle	720 ft. x 490 ft.	_____	_____
5. Triangle	27 ch. x 36 ch.	_____	_____
6. Rectangle	9 rds. x 6 rds.	_____	_____
7. Rectangle	500 lks. x 38 rds.	_____	_____
8. Square	(6 chains, 2 rods, 23 links)	_____	_____

9. Calculate the square footage and the acreage for the following parcel. Note that the figure is the same on the right side as on the left side.

A = _____ SF
B = _____ SF
C = _____ SF

Total _____ SF

Total Acres = _____

10. Calculate the square footage and acreage for the following parcel.

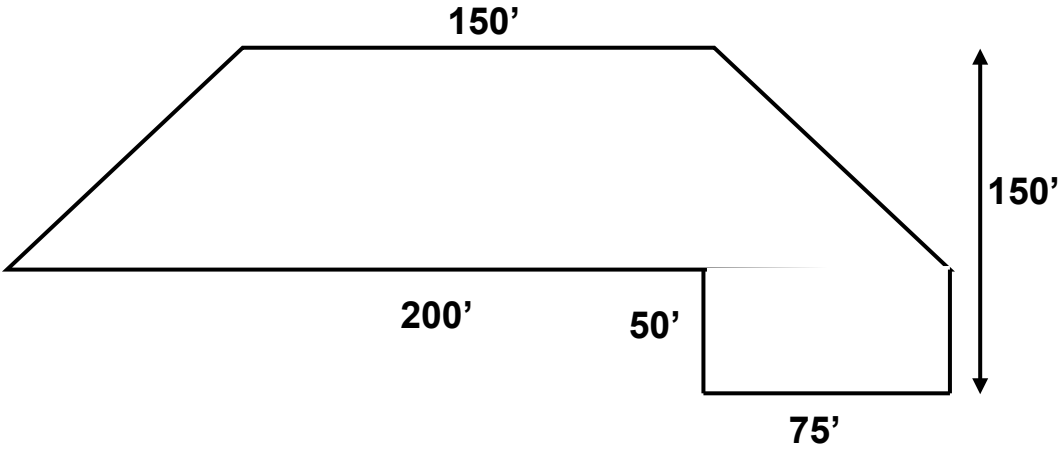

SF _____

Ac _____

Unit 3 The U.S. Rectangular Land Survey

Learning Objectives

After completing the assigned readings, you should be able to

- understand the history of the U.S. Rectangular Land Survey.
- define the components of survey system.
- locate a position using the system.

Terms and Concepts

Baseline
Government Survey
Latitude
Longitude
Political Township
Principal Meridian
Section
Section Number
Township
Meridian Line
Quarter Section
Range

A Little History...

Historically, land was surveyed using the indiscriminate **metes and bounds** system. This survey system used natural land features, such as trees and streams, as well as neighboring land owners, along with distances to describe plots of land. Realizing that metes and bounds descriptions would never prove satisfactory in the largely uninhabited **Northwest Territory** (what is now Ohio, Indiana, Illinois, Michigan, and Wisconsin), the Continental Congress knew it had to develop a plan for the orderly sale of individual tracts to the public. In 1784, a committee headed by Thomas Jefferson developed a plan for dividing this public land into rectangles. The new system was based on a series of coordinates – **meridians and base lines** – plotted astronomically by surveyors.

The Continental Congress established the rectangular survey system in the Land Ordinance of 1785, also known as the Northwest Ordinance. Under terms of the Ordinance, Congress was to appoint one surveyor from each state to serve under the direction of the Geographer of the United States.

The basic plan called for by Jefferson's committee developed three theories:

1. the principal of "survey before settlement".
2. the principal of a mathematically designed plan to be followed throughout the entire public domain area.
3. the creation of a standard land unit, the section of uniform shape and area and with boundaries physically marked on the ground.

On October 1, 1796, Washington appointed Rufus Putnam as the first Surveyor General of the United States. He was the author of the present numbering system and placed the excess and deficiency in the North and West tiers of the townships. The Land Act of 1796 was the first law concerning surveys.

Between 1851 and 1855 the Land Act was amended several times and set the pattern for the present-day survey system.

The Rectangular Survey System as we know it today is a system based on tiered townships and ranges that are tied to thirty-five established principal meridians located across the country.

Boundaries for the Rectangular Survey System were usually marked by placing markers or using prominent trees as boundary markers. These boundary markers are referred to as **monuments**.

Monuments are tangible landmarks indicating boundaries. There are 5 different types of monuments.

1. A **physical monument** is an existing feature such as a stone or stake but not the line of an adjoining property.
2. A **natural monument** is a naturally occurring object such as a lake, river, tree, boulder or hill.
3. An **artificial monument** is a man-made object such as a stake, fence, set stone, etc.
4. A **record monument** is an adjoining property called for in a deed such as a street or a parcel of land.
5. A **legal monument** is any monument referenced in a legal description for the purposes of identifying property.

The map below illustrates the principal meridians and baselines within the United States.

US Principal Meridians and Baselines

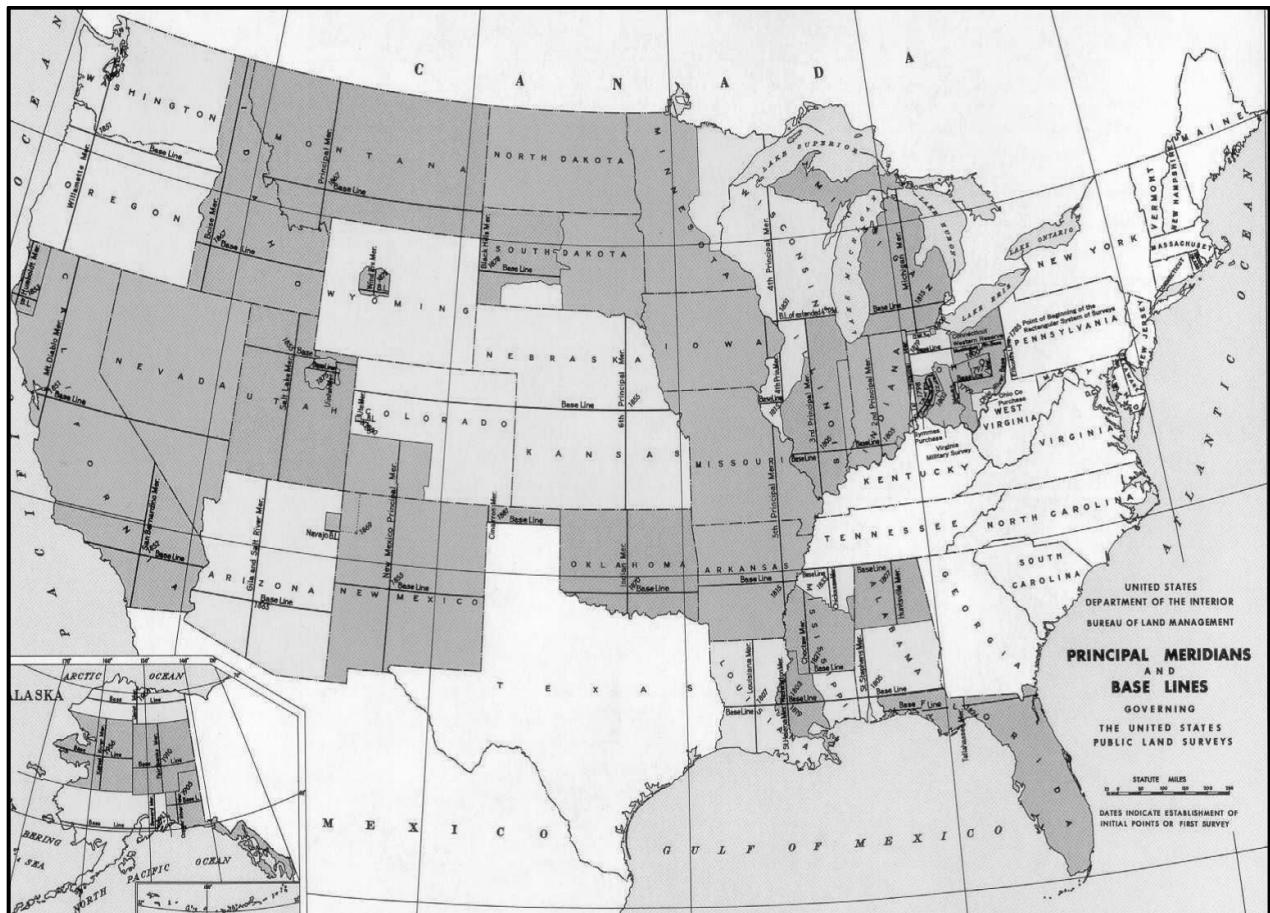

Illinois Meridians and Baselines

A **latitude** line is an east-west circle, measuring degrees north or south of the Equator. A **baseline** is a parallel of latitude running through an arbitrary point chosen as the starting point for all sectionalized land descriptions within a given area.

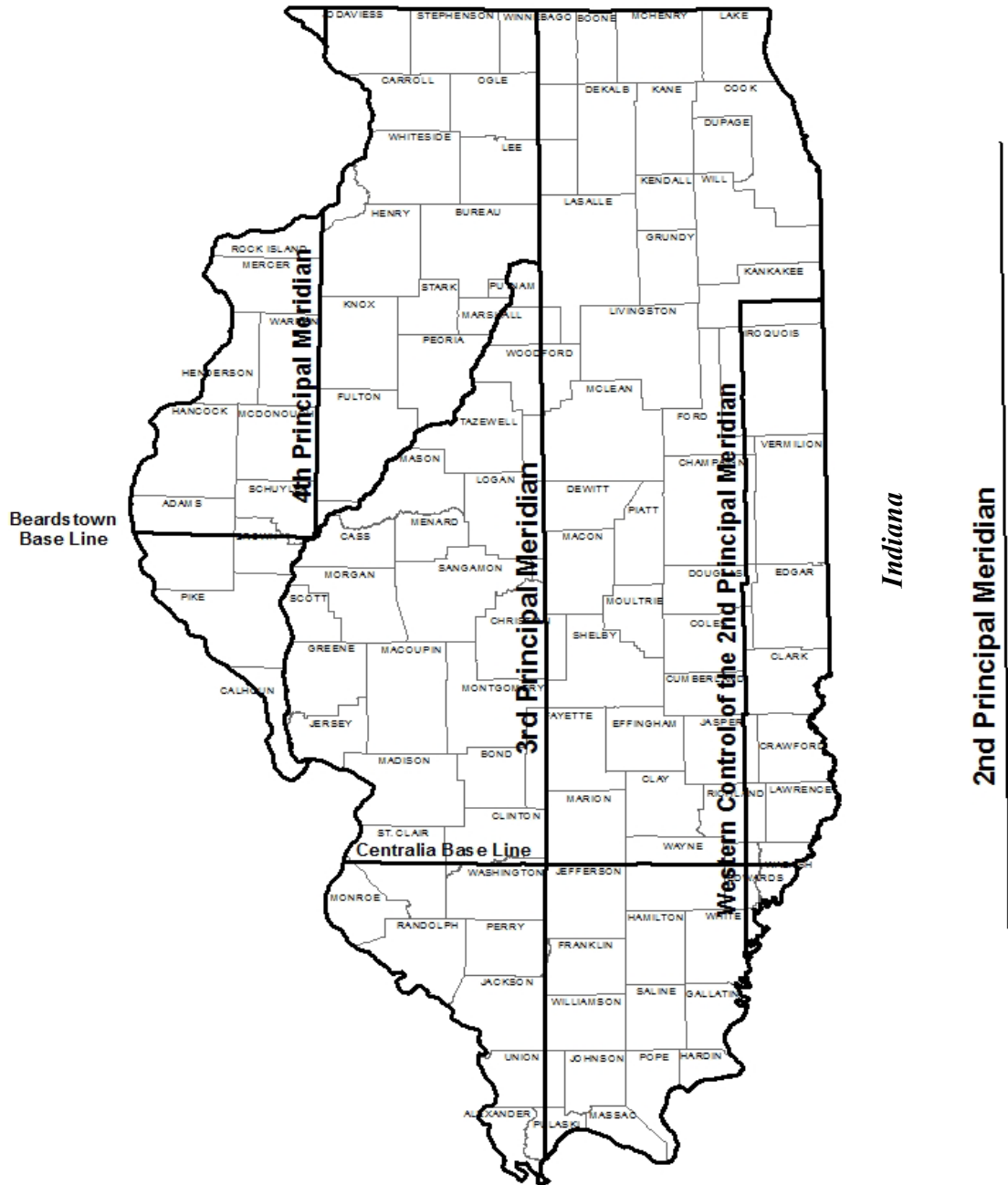

A **longitude** line is a north-south circle measuring degrees east and west of zero longitude at Greenwich, England. A **principal meridian** is an arbitrary line of longitude used as a starting point and reference for all sectionalized land.

In Illinois, there are two baselines and reference to three principal meridians. The most prominent meridian is the Third Principal Meridian, which virtually cuts Illinois in half. **Where a baseline and principal meridian intersect is considered a reference.** The reference for the Third Principal Meridian exists at the intersection of the Centralia Baseline. This baseline runs east and west through Centralia, Illinois. The Second Principal Meridian, located in Indiana, shares the Centralia Baseline for its reference.

Property located in Eastern Illinois is unique. Part of it is referenced to the Third Principal Meridian, and part of it is referenced to the Western Control of the Second Principal Meridian, which is actually located in Indiana.

Finally, property in Illinois west of the Illinois River or west of the Third Principal Meridian is referenced to the Fourth Principal Meridian. The reference point for the Fourth Principal Meridian is the Beardstown Baseline. The baseline runs west of Beardstown, Illinois.

Once we know the meridian and the baseline for a property, we can determine the general location of any property anywhere in the country governed by the Rectangular Survey System.

Congressional Townships and Ranges

Numbering of townships and ranges begins at the reference point of a principal meridian and a baseline. Township numbers increase away from the baseline using the direction from the baseline as an indicator (north or south). Range numbers increase away from a principal meridian using the direction from the principal meridian as an indicator (east or west).

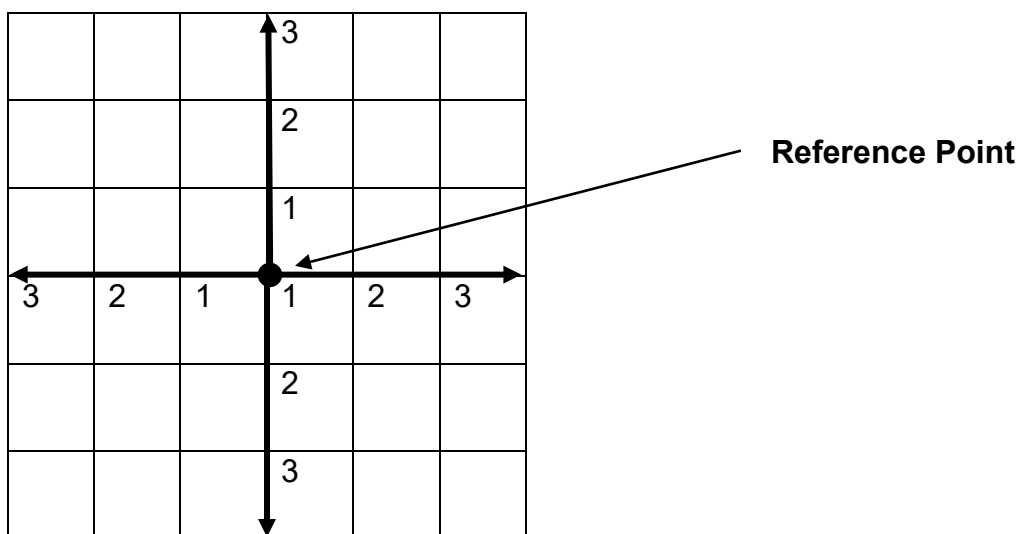

Each township is six miles by six miles, or thirty-six square miles in size (6 miles square). The township identified with the arrow is three townships south of the baseline and two ranges east of the principal meridian.

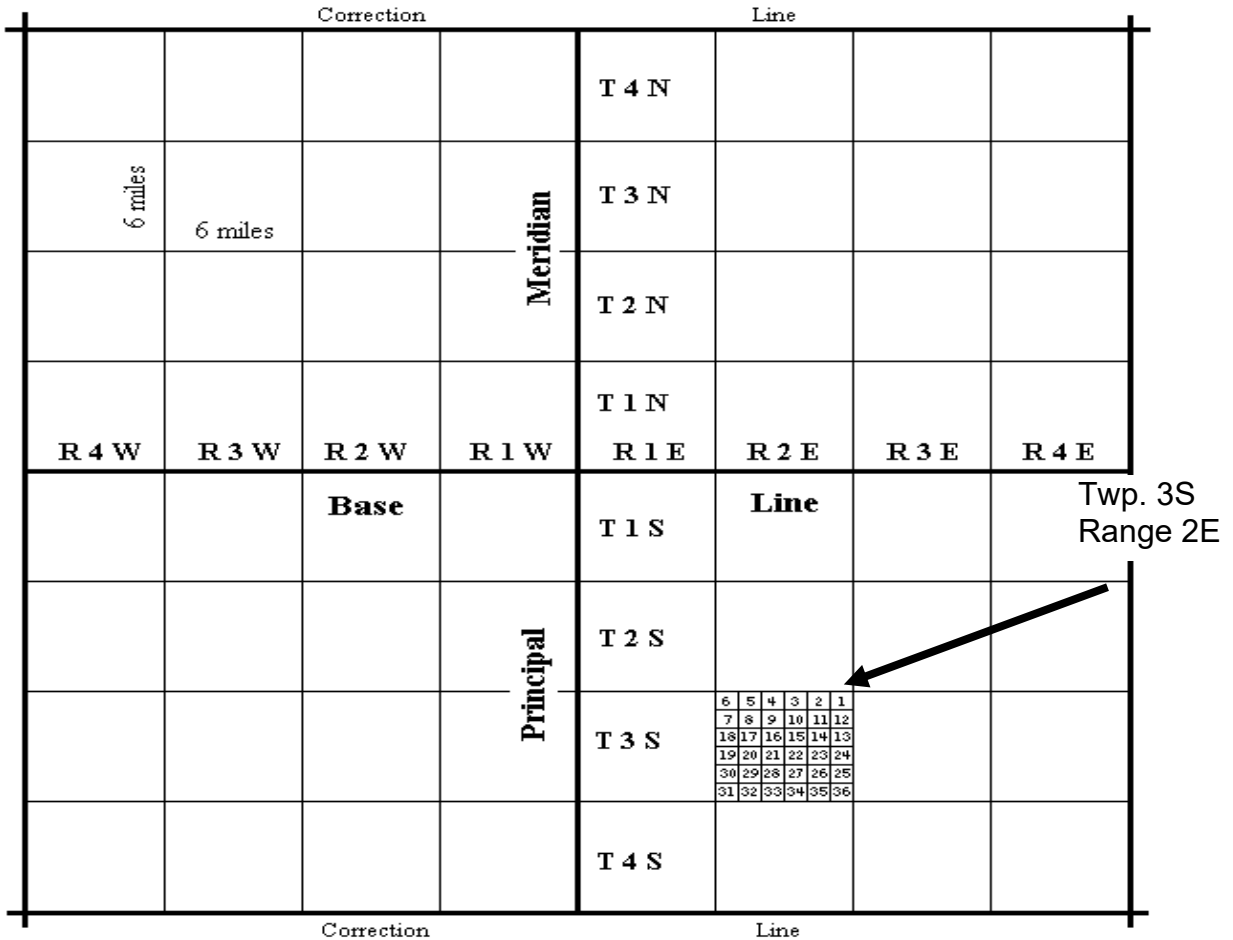

Sections

A section is a one-mile square block of land containing 640 acres. There are 36 sections within each township. Numbering of the sections begins in the northeast corner of the township, and progresses west then east, back and forth in a serpentine manner as illustrated by the dashed line. This numbering method is referred to as “boustrophedon”, meaning “as the cow plows”.

Why are sections numbered in this unusual way? Remember, the Rectangular Survey System was plotted in the early to mid-1800’s by survey teams carrying chains and poles and supplies. As they measured each section and moved on by foot, horseback or wagon, it was physically easier and more efficient for the surveyors to continue working and numbering the sections in this way.

Any correction to the size of the township due to measuring error occurs along the western or northern side. As a result, the sections along the western and/or northern side of the township may not equal one-mile square.

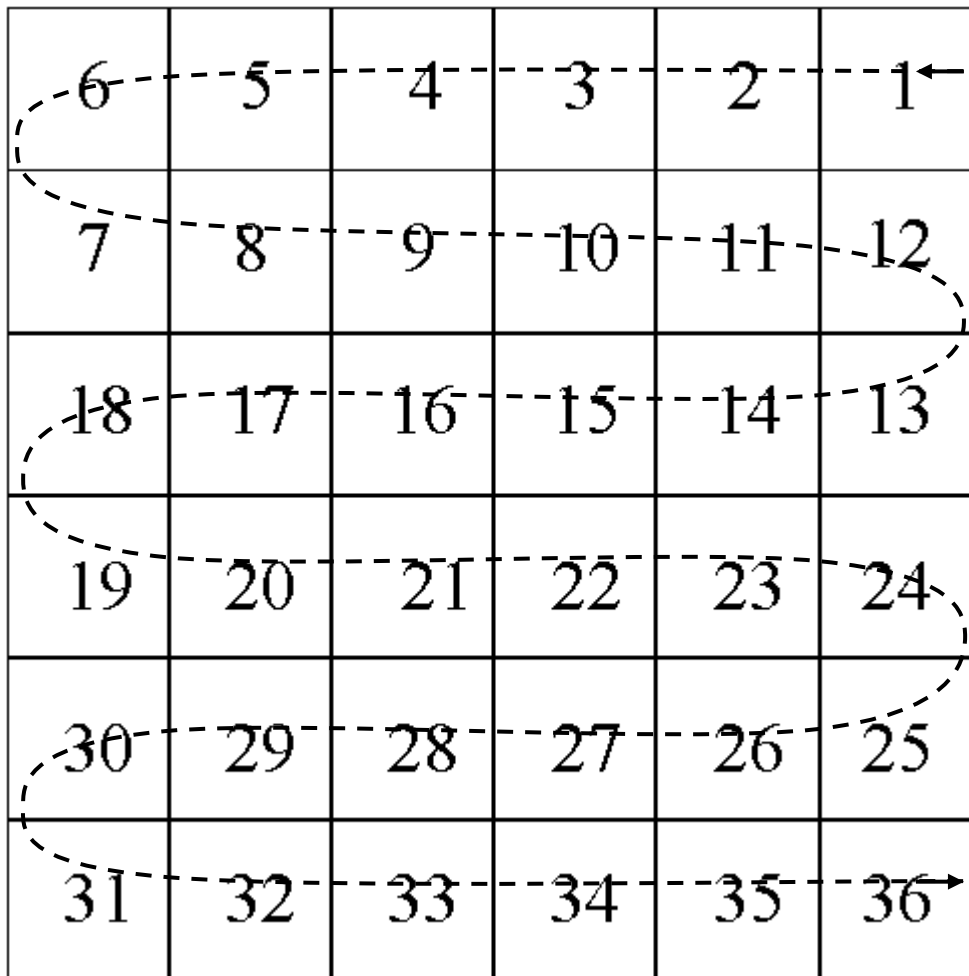

Exercise 3-1 Locating Townships and Sections

This exercise is designed to help you more precisely pinpoint areas or tracts of land. Locate the following and place the appropriate letter in the proper location.

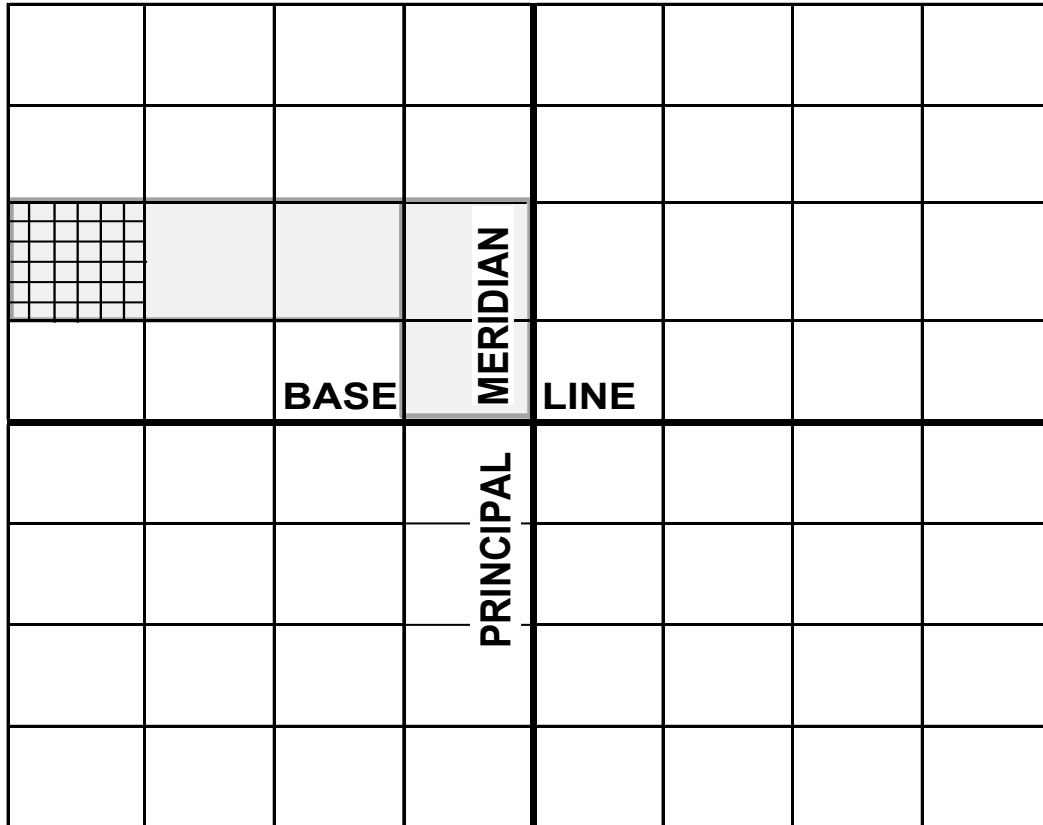

- A. Township 2 North, Range 4 East
To locate this tract, count two squares (townships) up from the baseline, and four squares (ranges) to the right of the principal meridian line.
- B. Township 4 South, Range 2 West
- C. Township 3 North, Range 2 West
- D. Township 1 South, Range 3 East
- E. Section 16, Township 2 North, Range 4 West
- F. Section 1, Township 2 North, Range 4 West
- G. Section 36, Township 2 North, Range 4 West
- H. Section 26, Township 2 North, Range 4 West

Principal Meridians and Baselines

Many legal descriptions pass through county offices. Sometimes a legal is written incorrectly, which makes finding the property in question very difficult. However, a simple check of the principal meridian, baseline, township and range values can quickly identify if the legal description is in your jurisdiction. For example, if you are reading a legal description for property supposedly in Rock Island County and it is referenced to the Third Principal Meridian, the legal quickly becomes suspect. So, with that in mind, review the following parcel references and determine what part of the state it is in (for example, N, S, E, W, C, NW, NE, SW, SE, etc.).

Distances are marked on the drawing.

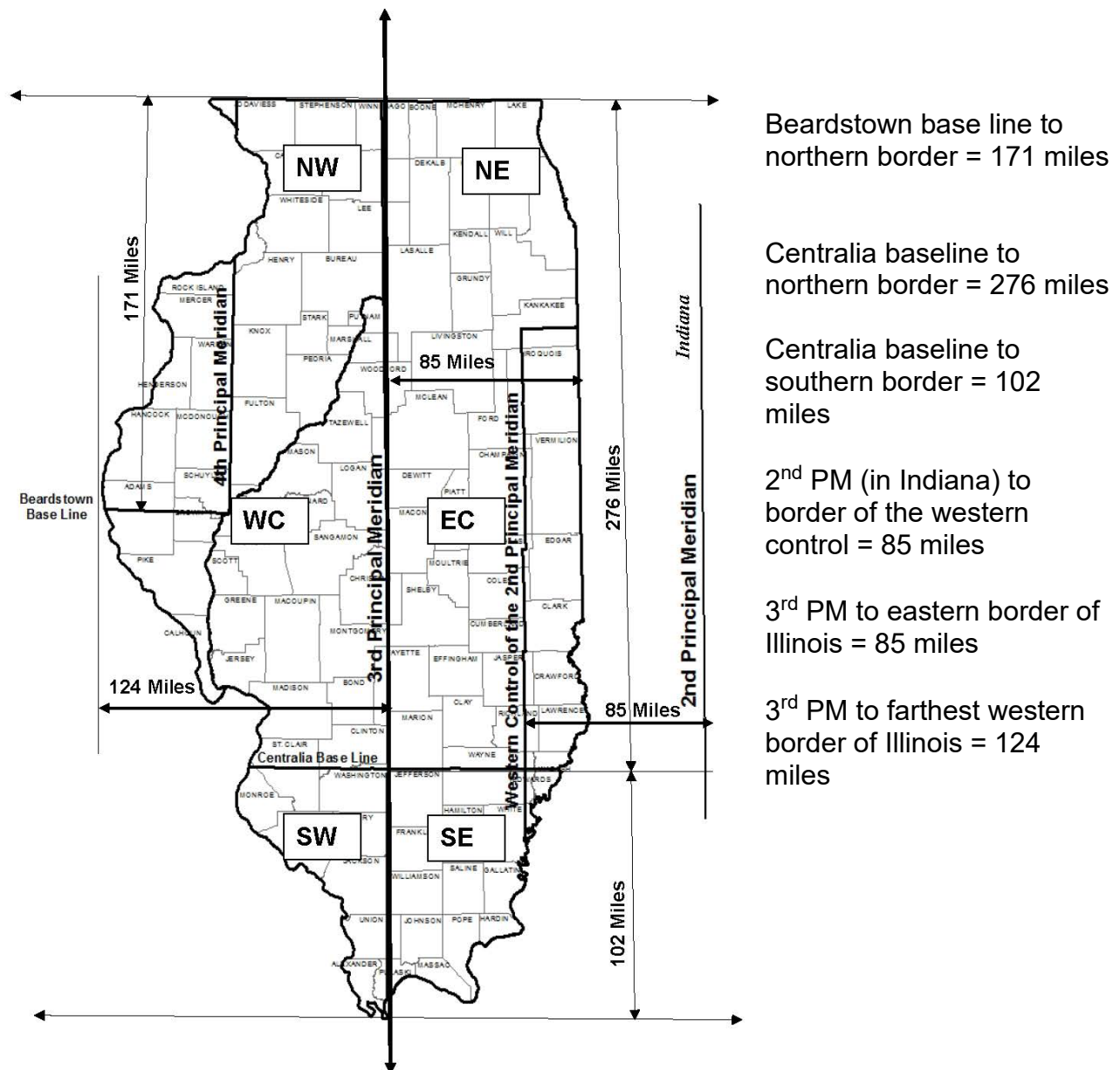

This exercise is designed to familiarize you with the concept of baselines and principal meridians in locating property. Remember that each township/range is six miles by six miles square. In the first question, since a township is six miles by six miles, 12 S = 72 miles south of Centralia and (Range) 1 W is 6 miles west of the 3rd PM.

Exercise 3-2 Locating Townships and Ranges

Find which area of the state the description is in and the approximate miles from the reference point-use the mileage indicators on the following page.

	<u>Location</u>	<u>Township Miles</u>	<u>Range Miles</u>
1. T12S-R1W, 3rd PM	<u>South or Southwest</u>	_____	_____
2. T43N-R10E, 3rd PM	_____	_____	_____
3. T27N-R4E, 4 th PM	_____	_____	_____
4. T20N-R3W, 3rd PM	_____	_____	_____
5. T2N-R11W, 2 nd PM	_____	_____	_____
6. T3S-R7W, 4 th PM	_____	_____	_____

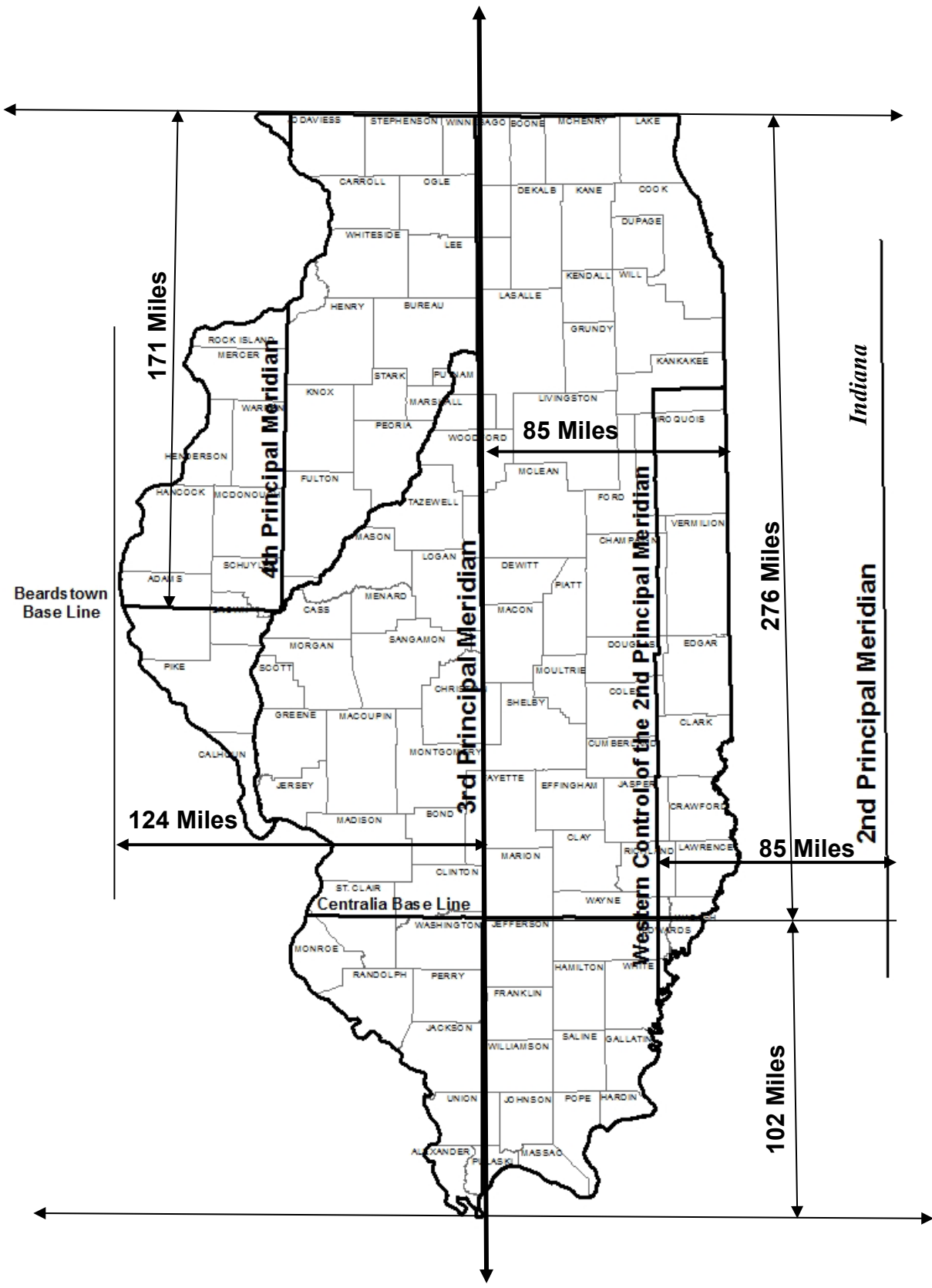

Indiana

Unit 3 Summary

The Rectangular Survey System is based on a series of **Meridians** and **Baselines** that were meant to replace the older metes and bounds method of land measurement and description

It is a system based on tiered townships and ranges that are tied to thirty-five established principal meridians located across the country.

- A township is a nearly six-mile square area of land containing 36 sections.
- A section is a one-mile square block of land containing 640 acres, or one thirty-sixth of a township. Sections are numbered in a serpentine fashion, beginning in the northeast corner. A Section contains 640 acres.
- A range is a vertical column of townships in the rectangular survey system.
- Townships measure distance north and south of a referenced baseline; ranges measure distance east and west of a referenced principal meridian.

Illinois has reference points for the 2nd, 3rd and 4th Principal Meridians and the Beardstown and Centralia Baselines

Thomas Jefferson was one of the founders of the Rectangular Survey System.

Using the U.S. Rectangular Survey System, once we know the section, township, range, principal meridian, and baseline, we can locate any piece of property to within one mile.

Monuments are tangible landmarks that indicate boundaries.

- physical - an existing feature such as a stone or a stake.
- natural - an existing feature such as a lake, river, tree, boulder or hill.
- artificial- a man-made object such as a stake, fence, set stone, etc.

A monument record is a document describing the location of a monument with ties to witnessed monuments.

A legal monument is any monument referenced in a legal description for the purposes of identifying property.

Unit 3 Review Questions

1. Sections are numbered in a _____ fashion, beginning in the _____ corner. There are _____ sections within a township/range tier.
2. Legal descriptions using the Rectangular Survey System are tied to base lines and meridians. In Illinois, these descriptions are governed by the _____, _____, or _____ Principal Meridians and by the _____ Baseline or the _____ Baseline.
3. The _____ Principal Meridian virtually cuts Illinois in half. The _____ Principal Meridian is partially located in Indiana. Both are tied to the _____ Baseline. The _____ Principal Meridian is in the northwest portion of the state, and is tied to the _____ Baseline.
4. A committee headed by _____ developed a plan for dividing public land into rectangles. This plan was the basis for the _____ Ordinance of 1785.
5. A township is a nearly square area of land. Each township is _____ miles square and contains _____ square miles. The first township north of a baseline would be referenced as township _____.
6. T44N – R2E, of the 3rd Principal Meridian, is in the _____ part of the state of Illinois.
7. Identify the section number marked with an “X” in the township map below:

Cleary Township

			X		

“X” marks Section Number _____

Unit 4 Legal Descriptions

The purpose of this unit is to provide a detailed understanding of how real property is described. In addition, this unit will describe how to locate real property using a legal description.

Learning Objectives

After completing the assigned readings, you should be able to

- locate real property from a legal description.
- calculate acreage.
- define the different types of legal descriptions.
- understand the use of “thence”, “and”, “except” and “excepting”.

Terms and Concepts

Bearing
Cadastral Map
Commencing
Degree
Description
Exceptions
Index Map
Metes and Bounds
Monuments
More or Less
Parcel
Plat Map
Point of Beginning
Quarter Section
Range
Subdivision

Legal Descriptions

A legal description of property is a way to define or accurately pinpoint where a particular piece of property is located. A street address also identifies a physical location, but not in the same way that a legal description defines it, and in fact, they often do not even match!

The goal of assessing property for ad valorem purposes is to

- find the property,
- set up a method to legally describe the property, and
- value the property with an appropriate unit of comparison.

A legal description is defined as “a description in words judged legally sufficient to locate and identify a specific parcel.” The elements of a good legal description

- Must contain enough language to convey a sense of what is being described
- Include all the elements shown on the plat that is feasible
- Tell the story laid out on the plat-this is a narrative
- Have enough elements to reconstruct the description
- Describe, describe, describe.

There are several methods used for legally describing property. The main methods are

- Land Descriptions
- Lot-and-Block
- Metes and Bounds

Land Descriptions

Land descriptions are referenced to the government surveys described in Unit 3. A strength of the rectangular survey systems is that the land has been, for the most part, divided evenly. This makes property descriptions more uniform and predictable. Under the rectangular survey system, land can be described one of three ways:

- Fractional
- Acreage
- Lineal

When locating these parcels, the descriptions are read backwards to specifically locate the property:

Fractional - describing property using fractions of rectangles.

E 1/2, NE 1/4, Section 6, Township 3 N, Range 4 West of the 3rd Principal Meridian.

To locate this fractional description, begin by finding the 3rd Principal Meridian and its governing Centralia Baseline; then, locate Township 3 North, Range 4 West; next, locate Section 6 of that township; now locate the Northeast quarter of Section 6; finally locate the East ½ of that NE ¼ section.

Acreage - describing property using the acreage values associated with each fraction of a rectangle.

West 80 acres, NE 1/4 Section 6, Township 3 North, Range 4 West of the 3rd Principal Meridian.

To locate this acreage description, begin by finding the 3rd Principal Meridian and its governing Centralia Baseline; then, locate Township 3 North, Range 4 West; next, locate Section 6 of that township; next locate the Northeast quarter of Section 6; finally locate the West 80 acres of that NE ¼.

Lineal - describing property using the perimeter measurement of each fraction of a rectangle.

The East 400' of the Southeast Quarter of Section 7, Township 2 South, Range 1 East of the 3rd Principal Meridian.

To locate this lineal description, begin by finding the 3rd Principal Meridian and its governing Centralia Baseline; then, locate Township 2 South, Range 1 East; next, locate Section 7 of that township; next locate the Southeast quarter of Section 7; finally locate the East 400 feet of that SE ¼.

The diagram on page 70 illustrates how an individual section of the rectangular survey system can be dissected using land descriptions to describe property. The diagram shows section divisions and land measurements. A section is simply a large square that is one mile from east to west and one mile from north to south.

The large square, or section, can be divided into four equal parts creating the Northeast Quarter, the Northwest Quarter, the Southeast Quarter and the Southwest Quarter of the entire section.

Considering an entire section is 640 acres, by dividing the section by four (quartering the section) each quarter section is 160 acres ($640 \div 4 = 160$). Therefore, if a property

is described as the NW $\frac{1}{4}$ section, the total acreage of that property is 160 acres. Property can be further divided into a quarter-quarter section. If the property is described as the NW $\frac{1}{4}$ of the NW $\frac{1}{4}$, the section has been quartered twice ($640 \div 4 = 160 \div 4 = 40$); the property contains 40 acres. This division by one-fourth can continue to a quarter-quarter-quarter which would contain 10 acres, and a quarter-quarter-quarter-quarter containing 2.5 acres. Tracts smaller than 2.5 acres are generally described using the metes and bounds description.

Property can be dissected using any combination of fractional portions. For example, a single parcel can be the equivalent of one half of a section, or 320 acres. The half section can be the north half, the south half, the east half, or the west half.

Lot and Block

The lot-and-block system is also known as the recorded plat system. It refers to specific parcels of land identified by a lot number or letter and the block, or subdivision plat, in which the lot is located. A plat is a larger chunk of land area previously identified by another survey method. These descriptions are often used in assessment books, often referring to appropriate page numbers within those books. For example:

- Lots 1 and 4 in Block 30 in the Village of Good Hope, McDonough County, Illinois.
- Lot 4 in Block 28 in the City of Bushnell, according to Plat #2, pages 212-243 of said City, County of McDonough, State of Illinois.

When locating a parcel written in a lots and blocks description, it is necessary to read the description **backwards** to specifically locate the property. In the first example above, if we were to read the description in the order written, we would start with Lots 1 and 4. The question becomes Lots 1 and 4 where? It could be anywhere in the world.

Begin at the end. The parcel is in Illinois
 in McDonough County
 in the Village of Good Hope
 in Block 30
 Lots 1 and 4

By starting at the end of the description, we know that the lots are in the State of Illinois, the County of McDonough, the Village of Good Hope, and in Block 30 of the village.

Lot-and-block descriptions often correspond to Township Sections on a map.

Section 32 in Capitol Township

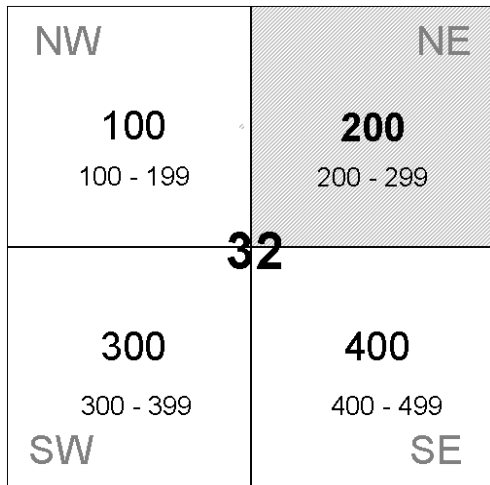

Section 32 in Capitol Township

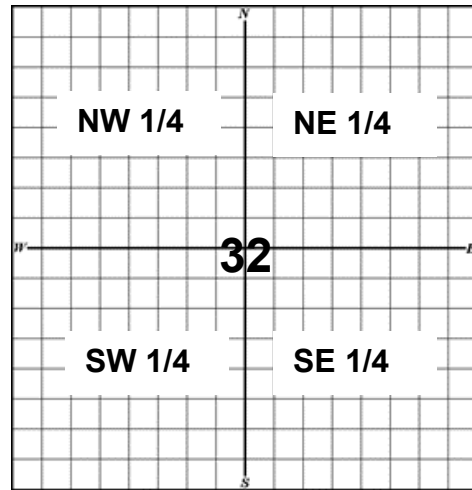

The Lot-and-block system can be used to clearly identify properties in dense urban and suburban areas.

The parcels shown on this plat would be located in the Northeast (NE) quarter of the section map (Block 200).

Blocks are numbered 100 (NW), 200 (NE), 300 (SW) and 400 (SE) to correspond with the quarter-sections.

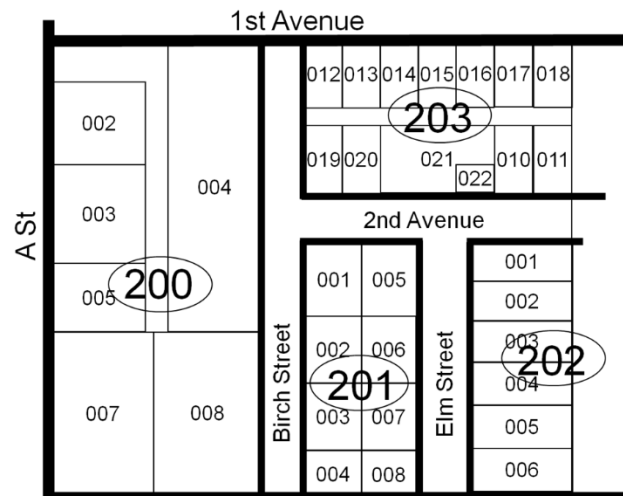

Metes and Bounds

Metes and bounds are used to describe **the perimeter** of property. When locating a parcel written in a metes and bounds description, it is necessary to read the first part of the land description portion backward to locate the point of beginning. Once the point of beginning is determined, the metes and bounds portion of the description is read in the order written. For example:

Commencing at the Southeast corner of the Northwest Quarter of Section 4, Township 7 North, Range 8 East of the 3rd Principal Meridian, thence North 50 feet to the point of beginning; thence West 550 feet; thence North 400 feet; thence East 550 feet; thence South 400 feet to the point of beginning.

In locating this property, we would first locate the 3rd Principal Meridian, and its governing Centralia Baseline. We would then find Range 8 East and Township 7 North. Within that Township and Range, we would locate Section 4. We would then locate the Northwest Quarter of that Section 4, and finally the Southeast corner of the Northwest Quarter. The Southeast corner is the point of beginning for our metes and bounds description. We would then read the metes and bounds description in the order written to determine the property boundary lines. By starting at the Southeast corner and going North 50 feet to the point of beginning; thence West 550 feet; thence North 400 feet; thence East 550 feet; thence South 400 feet to the point of beginning, we would have the exact location and boundary lines for our parcel.

Little Words Have Big Meanings

And, Also, and the Semi-colon (;)

When reading legal descriptions, little words have big meanings. If a fractional description reads “NE $\frac{1}{4}$ of the NE $\frac{1}{4}$ **and** SE $\frac{1}{4}$ of the NE $\frac{1}{4}$,” the “**and**” functions as a plus sign. You add the two descriptions together. **Also**, and the **semi-colon (;)** function as **and** as well. The “and” can also be found in linear and acreage legal descriptions.

“The E 160 acres **and** the N 80 acres of Section 16.”

“The SW $\frac{1}{4}$ of the SW $\frac{1}{4}$ **and** the S 40 acres of the NW $\frac{1}{4}$ of the SW $\frac{1}{4}$ ”.

“The NE $\frac{1}{4}$ NE $\frac{1}{4}$; NW $\frac{1}{4}$ NE $\frac{1}{4}$ **also** N 120 acres of the SW $\frac{1}{4}$ **and** SE $\frac{1}{4}$ of the NE $\frac{1}{4}$.”

Except and Excepting

When found in a legal description, the words “except” or “excepting” act as a minus sign. The description appears before the word **except** and the part of the description that follows is removed or excluded from the description. “Except” is often used when a portion of a larger property is sold, and it provides a quick way to modify an existing legal description as well.

“Section 16, Township 4S, Range 2 E of the 3rd Principal Meridian, **except** the SW $\frac{1}{4}$ of the SW $\frac{1}{4}$ ”.

Thence

The formal definition is “from a place or source previously mentioned, especially when you are giving directions about how to get somewhere”. Thence is often used in legal descriptions to indicate travel from a previous point along a prescribed path.

“Commencing at the SE corner of the SE corner, **thence** N 70 degrees West 660 feet to the point of beginning...”

Section Divisions and Land Measurement

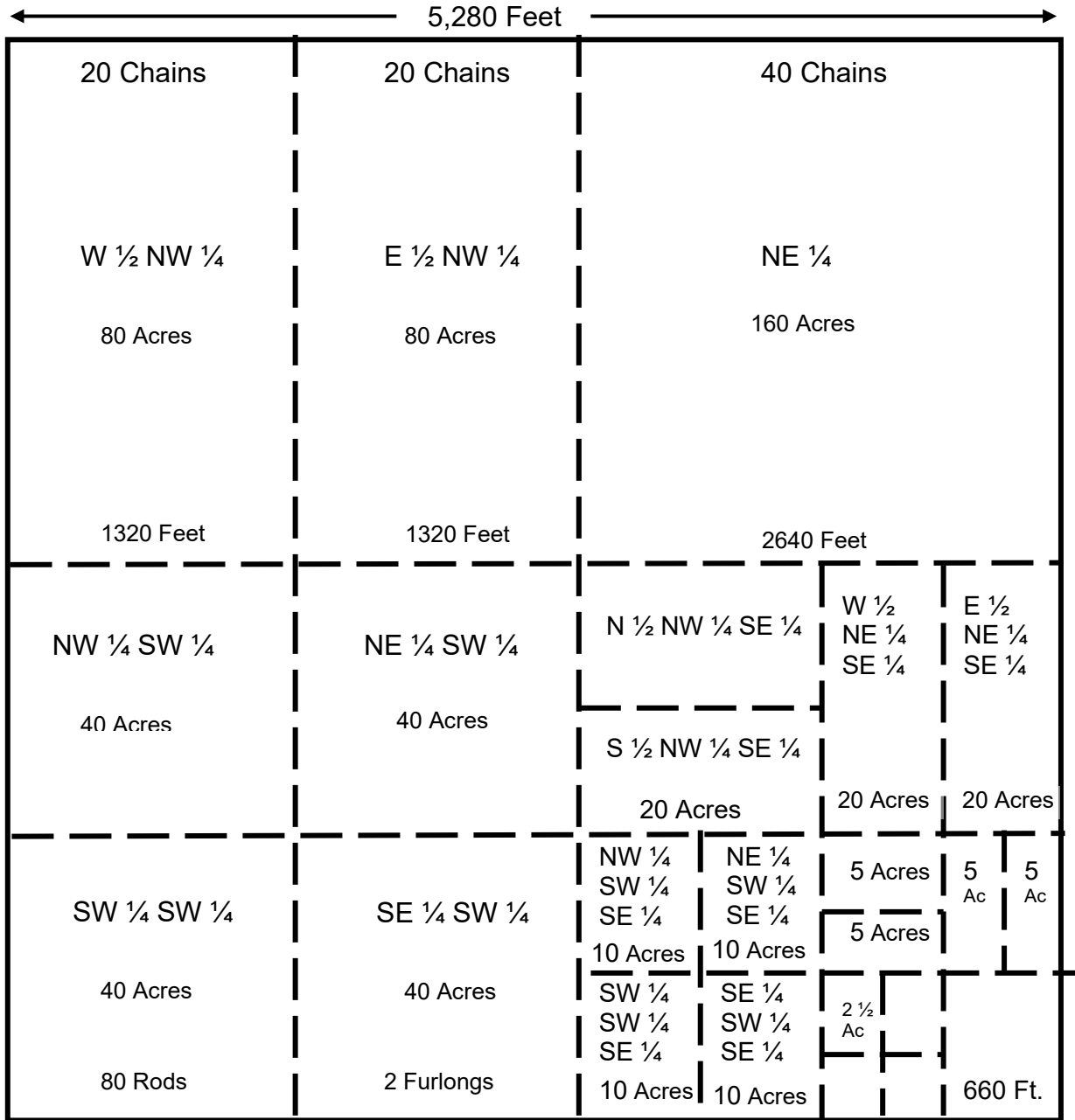

1 Link = 7.92 inches = .66 feet
 1 Rod = 16.5 feet
 1 Chain = 66 feet = 4 rods
 1 Furlong = 660 feet = 40 rods = 1,000 links
 1 Mile = 8 furlongs = 320 rods =
 80 chains = 5280 feet
 1 Acre = 43,560 square feet

1 section = 640 acres
 1/4 section = 160 acres
 1/4 1/4 section = 40 acres
 1/4 1/4 1/4 section = 10 acres
 1/4 1/4 1/4 1/4 section = 2.5 acres
 5,280 ft. = 1 mile
 2,640 ft. = 1/2 mile
 1,320 ft. = 1/4 mile
 660 ft. = 1/8 mile

Locating Legal Descriptions by the Fractional Method

When locating legal descriptions that are **fractional** (NE $\frac{1}{4}$ of the NW $\frac{1}{4}$ of the SE $\frac{1}{4}$), begin with the whole 640 acres of the section. Go to the end of the legal description for the last part of the section. In this example, the last part mentioned is "SE $\frac{1}{4}$." Divide the section into 4 equal parts (since the SE $\frac{1}{4}$ is described). Each part is 160 acres (640 acres in a section divided by 4). Now locate the SE $\frac{1}{4}$ on the grid.

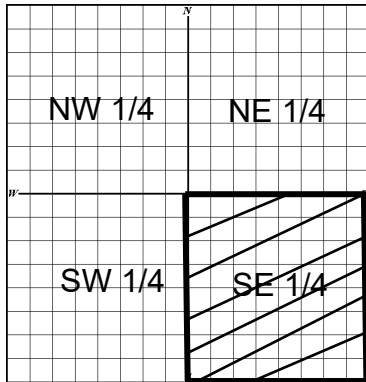

$$\text{SE } \frac{1}{4} = 640 \text{ acres} \div 4 = \underline{160 \text{ acres}}$$

Next, find the NW $\frac{1}{4}$ of this SE $\frac{1}{4}$.

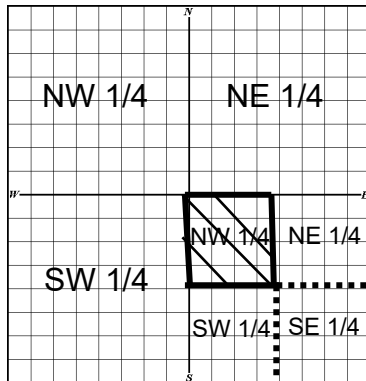

$$\text{NW } \frac{1}{4} \text{ of the SE } \frac{1}{4} = 160 \text{ acres (SE } \frac{1}{4}) \div 4 = \underline{40 \text{ acres}}$$

Now locate the NE $\frac{1}{4}$ of the NW $\frac{1}{4}$ of the SE $\frac{1}{4}$.

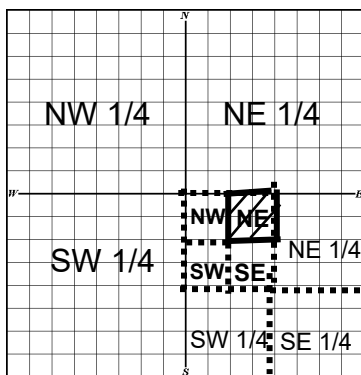

$$\text{NE } \frac{1}{4} \text{ of the NW } \frac{1}{4} \text{ of the SE } \frac{1}{4} = 40 \text{ acres} \div 4 = \underline{10 \text{ acres}}$$

The fractional method also refers to “halves” or “1/2 sections”: These can seem tricky, but just follow the same rules by reading the description backwards.

The South 1/2 of the SW 1/4.

Go to the SW 1/4

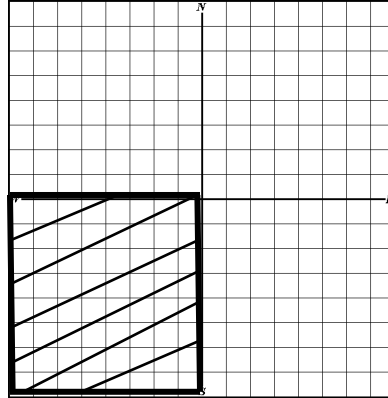

Then find the South 1/2 of that 1/4.

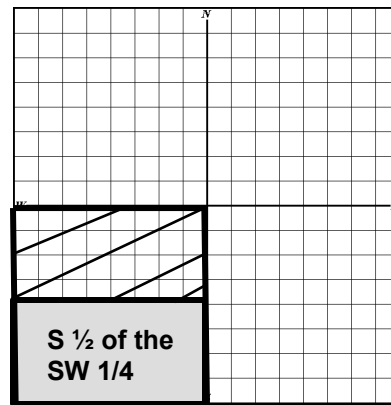

The Acreage method also refers to the northern, southern, eastern or western halves or “1/2” of sections, quarter-sections, quarter-quarter sections and quarter-quarter-quarter sections.

The same parcel above could be described as “**the South 80 acres of the SW 1/4**”. It is the SW 1/4 (160 acres) and the South 80 acres (1/2 of 160 acres).

Legal Descriptions with “And”

Both the fractional and acreage methods use “**and**” and “**also**” to indicate the adding together of described property. For instance, “The E 160 acres **and** the NW 1/4 of the NE 1/4 of Section 16.” First, find Section 16. Then, identify the “NW 1/4 of the NE 1/4”. The figure represents Section 16.

The NW 1/4 of the NE 1/4 would be located here as indicated by **A**.

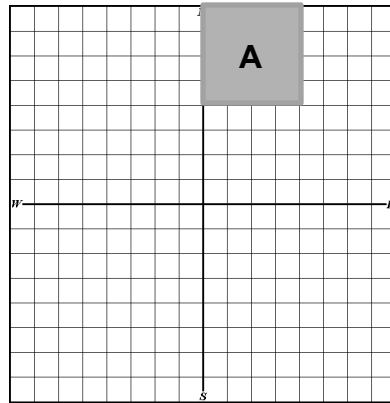

And, the E 160 acres of Section 16 would be located here as located by **B**

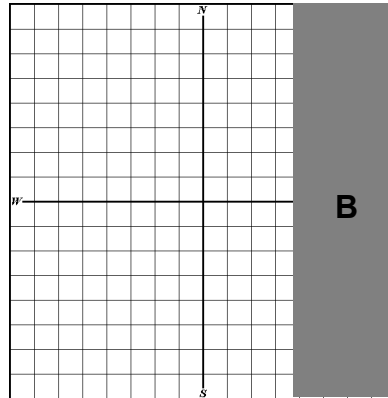

So, the entire parcel in this legal description would be **C** and total 200 acres:

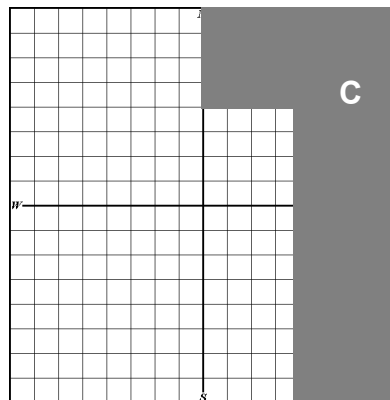

Another example using fractional descriptions E 1/2 of SW 1/4 **also the SW 1/4** of SE 1/4 of Section 21.

The figure represents Section 21.

The SW 1/4 of the SE 1/4

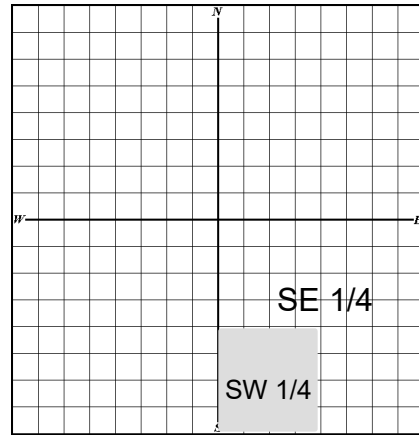

AND

The E 1/2 of the SW 1/4

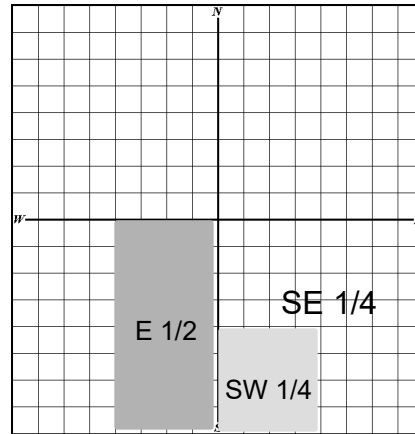

40 acres + 80 acres = **120 acres** total in the parcel described.

Unit 4, Exercise 4-1

Identify these parcels on the grid provided by shading in the appropriate parts on the grid. **Each Grid represents One Section.**

1. SE $\frac{1}{4}$ of SE $\frac{1}{4}$

_____ acres

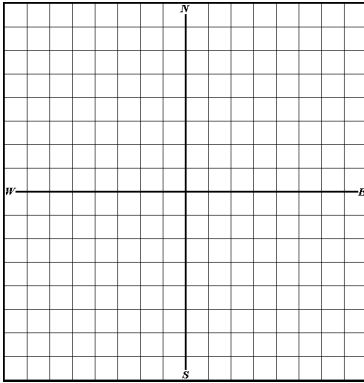

4. E $\frac{1}{2}$ of NW $\frac{1}{4}$ and NW $\frac{1}{4}$ of NW $\frac{1}{4}$

_____ acres

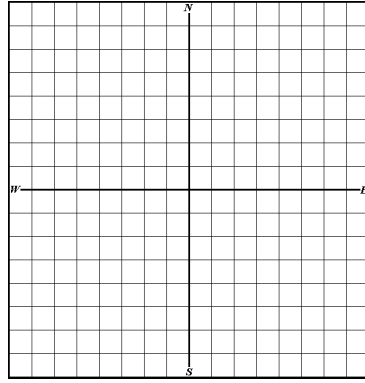

2. S $\frac{1}{2}$ of NW $\frac{1}{4}$

_____ acres

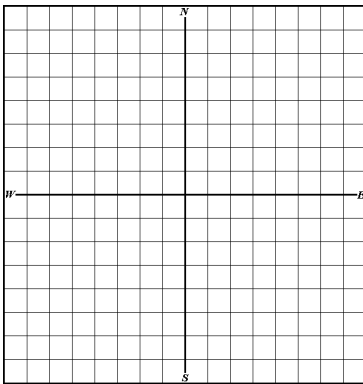

5. SW $\frac{1}{4}$ of SE $\frac{1}{4}$ of SW $\frac{1}{4}$

_____ acres

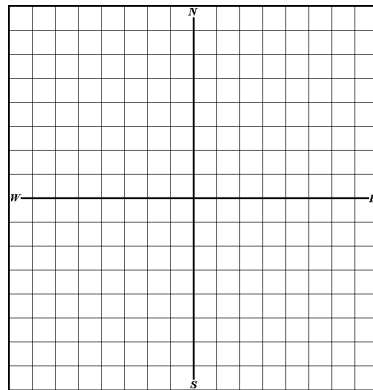

3. N $\frac{1}{2}$ of NE $\frac{1}{4}$ of SE $\frac{1}{4}$

_____ acres

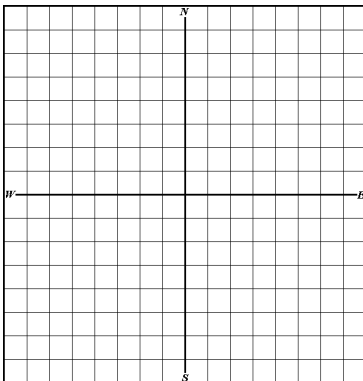

6. NE $\frac{1}{4}$ of NW $\frac{1}{4}$ of SW $\frac{1}{4}$

_____ acres

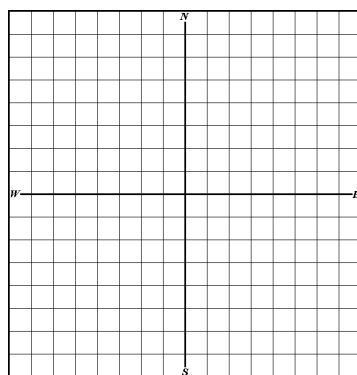

Legal Descriptions with Exceptions

As shown in the previous section, some legal descriptions are written combining previously measured areas, like acreage. Fractional measurements also can be combined, and parts can also be **excepted**, or not included. Refer to the following:

“A parcel described as the Northeast Quarter of the Southwest Quarter **and** the Northwest Quarter of the Southeast Quarter of Section 12, Township 11 South, Range 2 West of the 3rd P.M.

Excepting there from the land described above as Section 12, Township 11 South, Range 2 West of the 3rd P.M; the Southeast Quarter of the Northeast Quarter of the Southwest Quarter containing 10 acres.

The parcel herein conveyed containing 70 acres, more or less.”

Note: The acreage of the parcel conveyed will be equal to the acreage in the original parcel, minus the acreage in the exception. First draw the entire parcel and then draw the exception.

To begin, read the legal description backwards which refers to Section 12.

Then find the Southeast $\frac{1}{4}$.

Then find the Northwest $\frac{1}{4}$ of that $\frac{1}{4}$.

Section 12

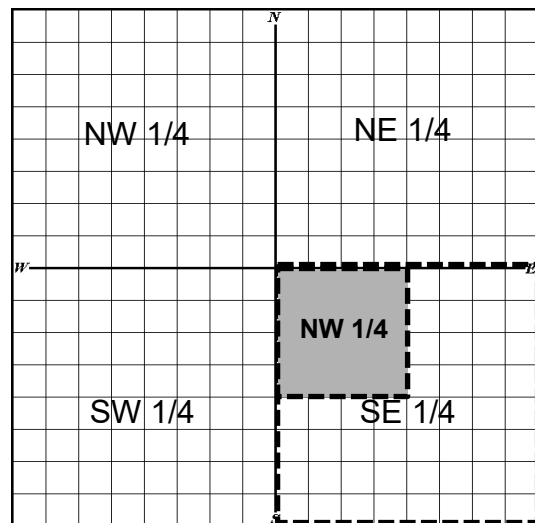

The description also says **AND** (reading backwards again) the Northeast $\frac{1}{4}$ of the Southwest $\frac{1}{4}$

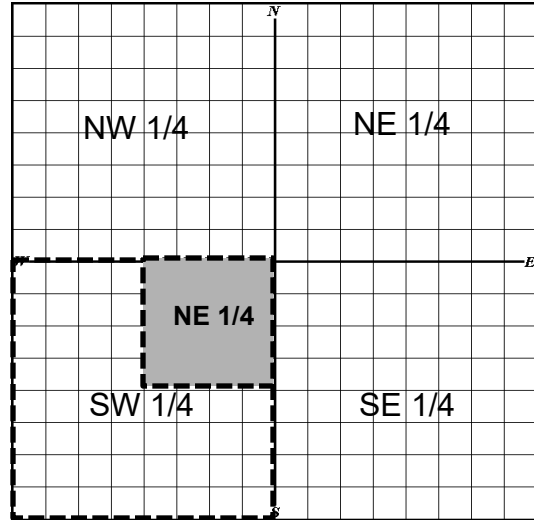

Next, you will **ADD** the two described sections together.

This is the original parcel described.

But, the description does not end there.

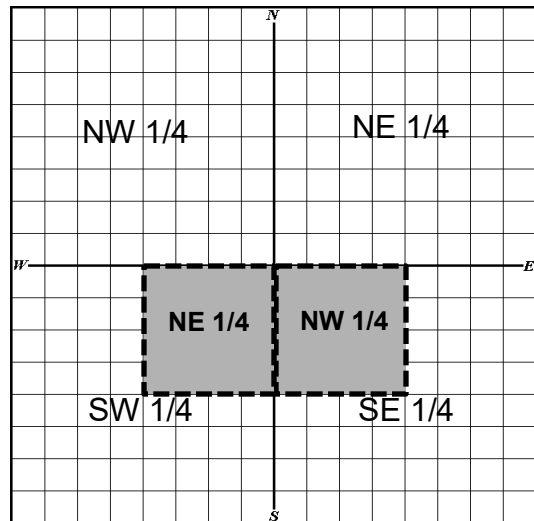

The description continues with **EXCEPT:** “from the land described above”, meaning the parcel just described, “the Southeast Quarter of the Northeast Quarter of the Southwest Quarter”.

Remember, reading backwards again, begin at the SW $\frac{1}{4}$, then the NE $\frac{1}{4}$ of that SW $\frac{1}{4}$, then the SE $\frac{1}{4}$ of that parcel indicated by the shaded area. That is the part of the description that is not included.

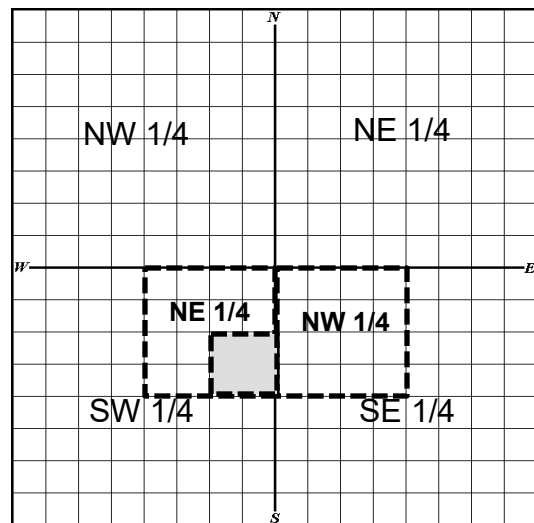

So, the actual parcel described is represented in the diagram by the shaded area.

Calculating the acreage from the description can be done quickly by looking at the diagram and by using the fractional measurements.

The "NW ¼ of the SE ¼" = 40 acres

The "NE ¼ of the SW ¼" = 40 acres

$40 + 40 = 80$ acres

EXCEPT (or minus) "The SE ¼ of the NE ¼ of the SW ¼" or 10 acres.

$80 \text{ acres} - 10 \text{ acres} = \underline{\mathbf{70 \text{ acres}}}$ total in the parcel.

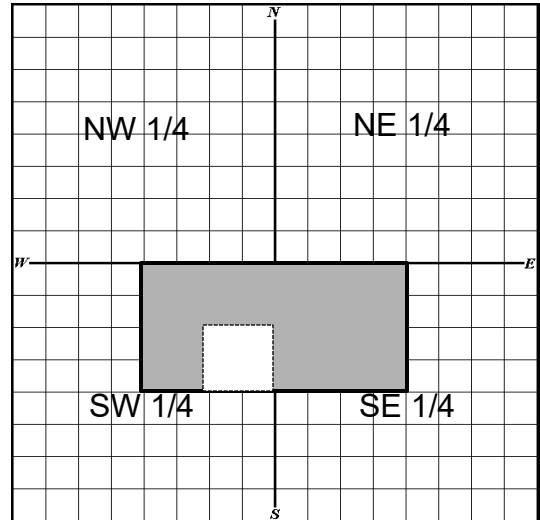

Unit 4, Exercise 4-2 Legal Description with Exception

Draw the parcel and calculate the acreage.

The parcel is described as:

The SE $\frac{1}{4}$ of the SE $\frac{1}{4}$ of the NE $\frac{1}{4}$ and the NE $\frac{1}{4}$ of the NE $\frac{1}{4}$ of the SE $\frac{1}{4}$ of Section 19, Township 11 South, Range 2W.

Except the SW $\frac{1}{4}$ of the NE $\frac{1}{4}$ of the NE $\frac{1}{4}$ of the SE $\frac{1}{4}$ as described above,

The entire remaining parcel containing _____ acres, more or less.

Section 19

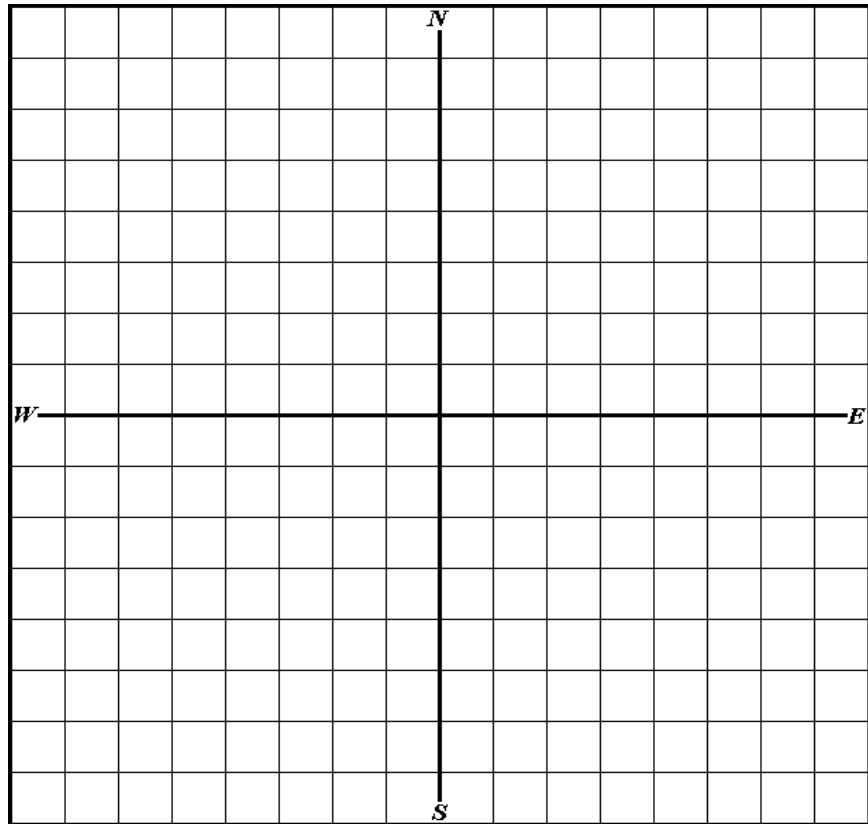

Unit 4, Exercise 4-3 Calculate the acreage for the following.

1. The Southeast Quarter of the Southeast Quarter of the Northwest Quarter 10; and the Southwest Quarter of the Southwest Quarter of the Northeast Quarter 10; and the Northwest Quarter of the Northwest Quarter of the Southeast Quarter 10; and the Northeast Quarter of the Northeast Quarter of the Southwest Quarter 10.

40 acres (Note: each $\frac{1}{4} \frac{1}{4} \frac{1}{4} = 10$ acres x 4 = 40 acres in the entire parcel).

2. The East One-half of the Northeast Quarter of the Northeast Quarter of the Southeast Quarter; and the Southeast Quarter of the Northeast Quarter of the Southeast Quarter; and the North One-half of the Northeast Quarter of the Southeast Quarter of the Southeast Quarter.

_____ acres

3. The South One-half of the Southwest Quarter of the Southwest Quarter; and the South One-half of the Southeast Quarter of the Southwest Quarter; and the South One-half of the Southwest Quarter of the Southeast Quarter; and the Northeast Quarter of the Southwest Quarter of the Southeast Quarter; and the Northeast Quarter of the Northwest Quarter of the Southwest Quarter of the Southeast Quarter; and the Northwest Quarter of the Northwest Quarter of the Southwest Quarter of the Southeast Quarter.

_____ acres

4. The Northeast Quarter of the Northeast Quarter; and the North One-half of the Northwest Quarter of the Southeast Quarter of the Northeast Quarter; and the Northeast Quarter of the Northeast Quarter of the Southwest Quarter of the Northeast Quarter.

_____ acres

5. The Southwest Quarter of the Southwest Quarter of the Northwest Quarter; and the Northwest Quarter of the Southwest Quarter of the Northwest Quarter; and the Southwest Quarter of the Northwest Quarter of the Northwest Quarter.

_____ acres

6. The Northwest Quarter of the Northwest Quarter of the Southeast Quarter of the Northwest Quarter; and the Northeast Quarter of the Northeast Quarter of the Southwest Quarter of the Northwest Quarter; and the Southeast Quarter of the Southeast Quarter of the Northwest Quarter of the Northwest Quarter; and the Southwest Quarter of the Southwest Quarter of the Northeast Quarter of the Northwest Quarter. _____ acres

Locating Legal Descriptions by Acreage

When locating legal descriptions that are by **acreage** (W 10 acres of the NW $\frac{1}{4}$ of the SE $\frac{1}{4}$), begin with the whole 640 acres of the section. Locate the NW $\frac{1}{4}$ of the SE $\frac{1}{4}$ as in the previous example.

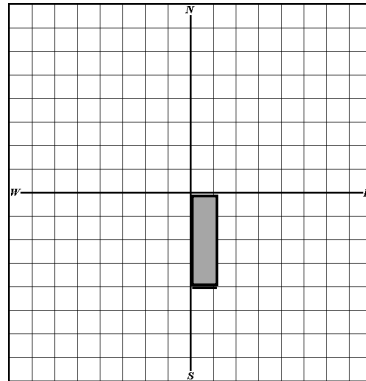
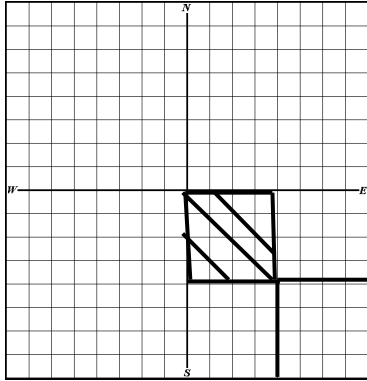

West 10 acres of the
NW $\frac{1}{4}$ of the SE $\frac{1}{4}$

The NW $\frac{1}{4}$ of the SE $\frac{1}{4}$ contains 40 acres. $640 \text{ acres} \div 4 \div 4 = 40 \text{ acres}$. The legal description calls for the west 10 acres of this. These 10 acres will be on the west side of the 40 acres.

S 40 acres of NW $\frac{1}{4}$

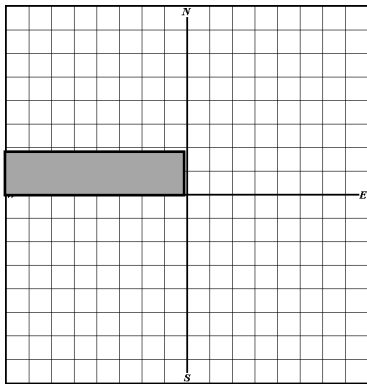

N 20 acres of SW $\frac{1}{4}$

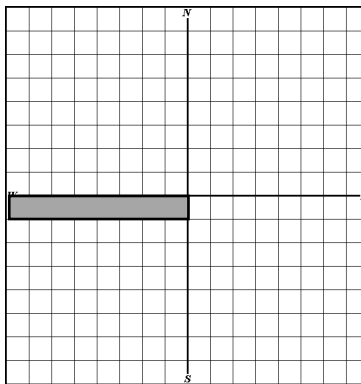

E 120 acres of NE $\frac{1}{4}$

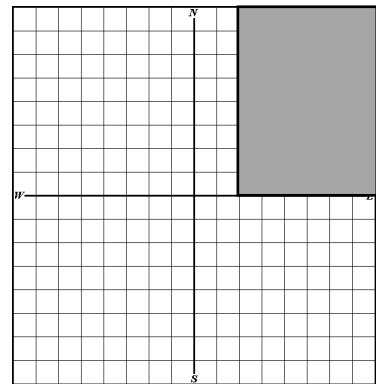

Unit 4, Exercise 4-4

Locate the following parcels on the grid.

1. The E 80 acres of the N 320 acres.
2. The N 40 acres of the E 80 acres of the NW $\frac{1}{4}$.
3. The N 40 acres of the SW $\frac{1}{4}$.
4. The S 80 acres of the SW $\frac{1}{4}$.
5. The E 20 acres of the NW $\frac{1}{4}$ of the NW $\frac{1}{4}$.
6. The S 5 acres of the SW $\frac{1}{4}$ of the SW $\frac{1}{4}$ of the SE $\frac{1}{4}$.
7. The NE 10 acres of the NW $\frac{1}{4}$ of the SE $\frac{1}{4}$.

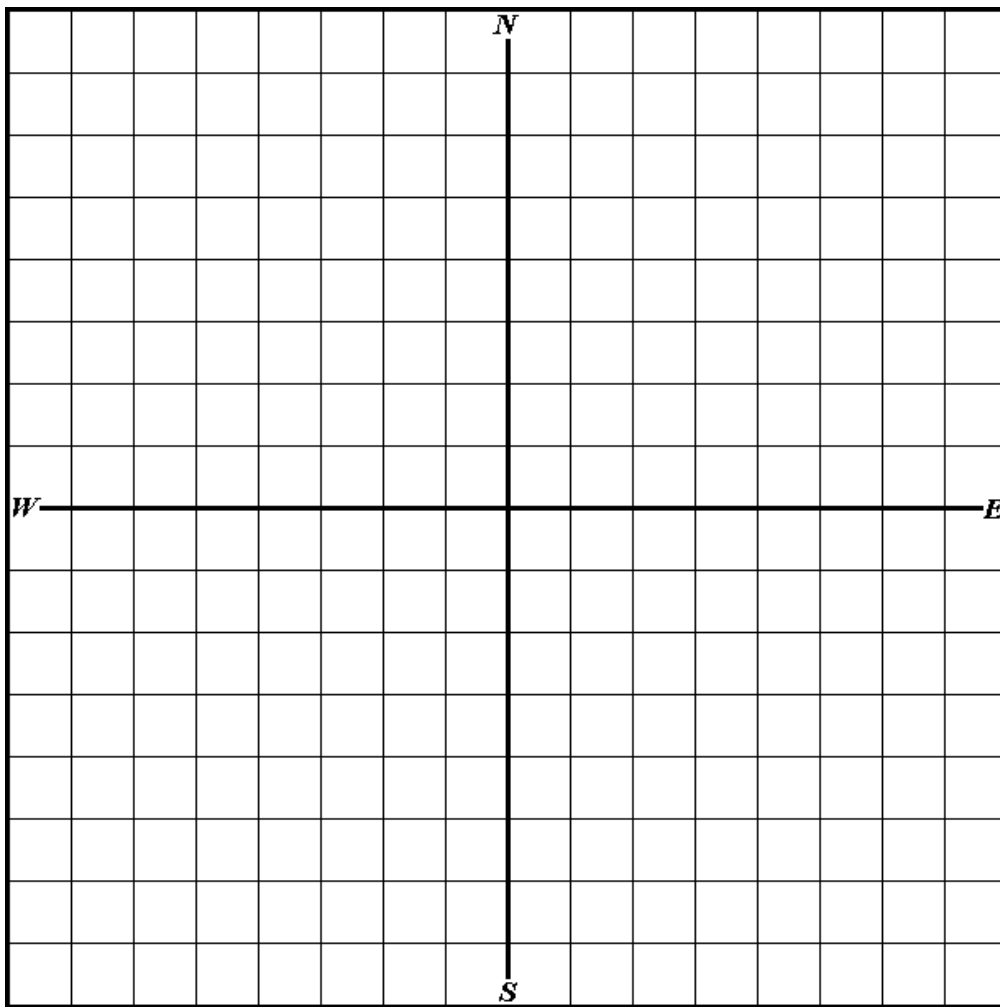

Locating Legal Descriptions with Linear Descriptions

Refer to the Section Grid on page 70. In addition to quarter-section measurements and acreage, the grid correlates to linear measurements.

An entire section is one-mile by one-mile square, or 5,280 ft by 5,280 ft. A quarter section measures 2,640 feet on each side; a quarter-quarter measures 1,320 ft; a quarter-quarter-quarter is 660 feet by 660 feet; and a quarter-quarter-quarter-quarter measures 330 feet on each side. Looking at the grid, notice how the linear feet relate to acreage.

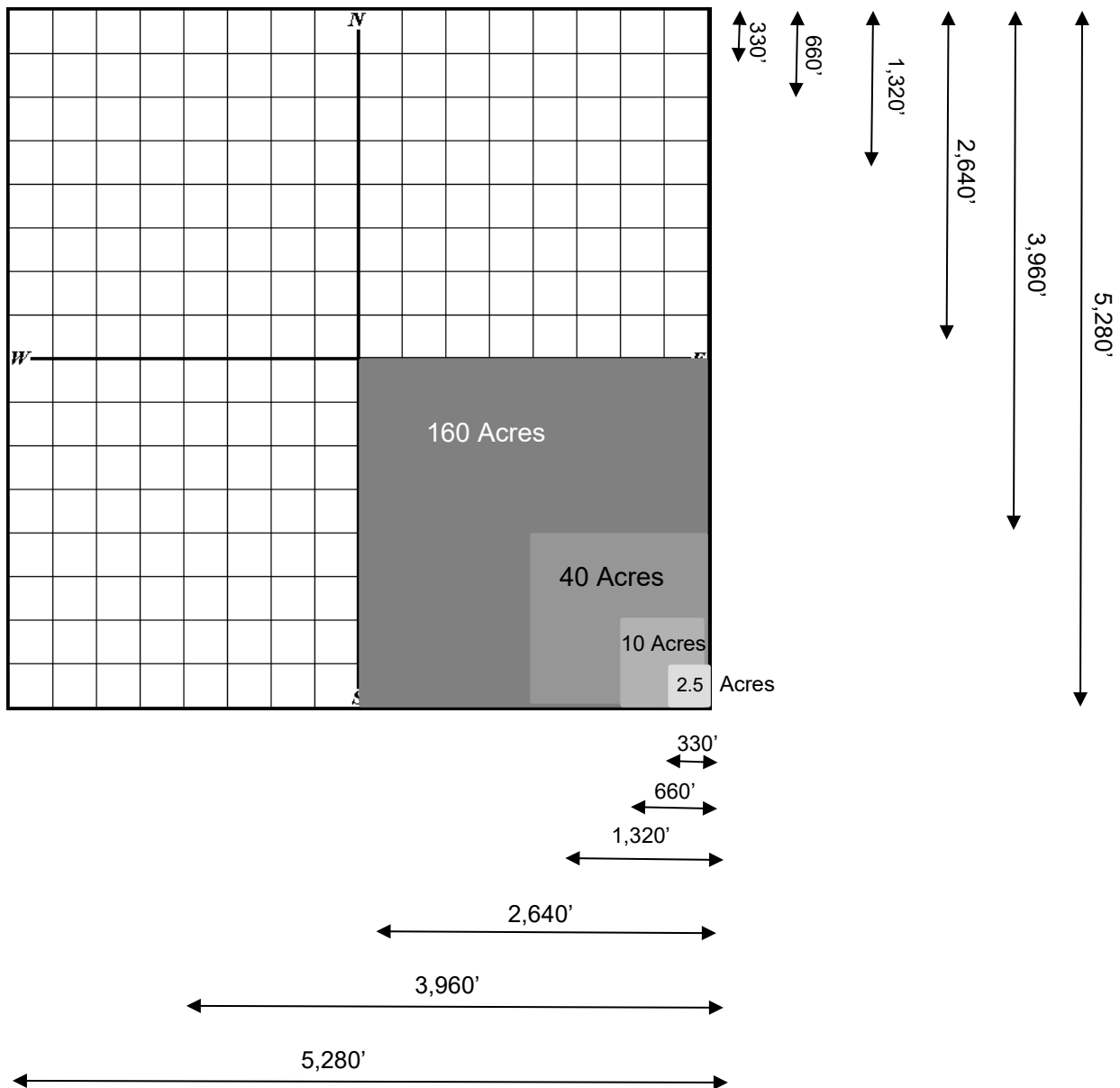

Unit 4, Exercise 4-5

Draw the following and calculate the correct acreage

1. Beginning at the Southwest corner of Section 12, thence North 2,640 feet; thence East 1,320 feet; thence South 2,640 feet; thence West 1,320 feet to the point of beginning.

Section 12

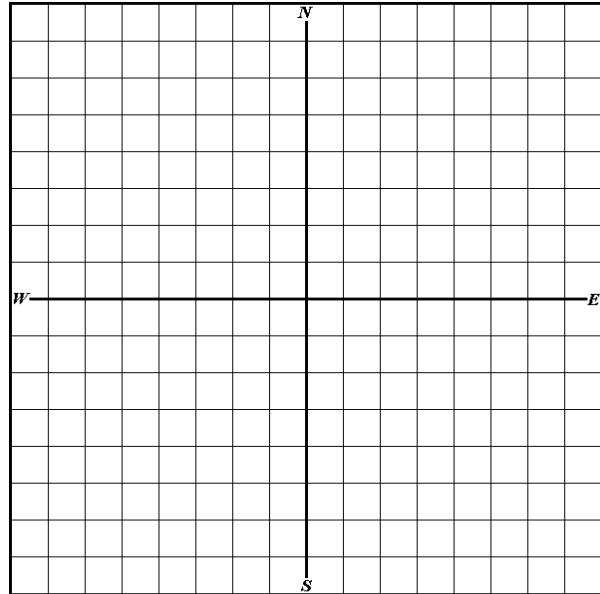

This parcel contains _____ acres.

2. Beginning at the Northeast corner of Section 32, thence West 1,320 feet; thence South 3,960 feet; thence East 990 feet; thence North 660 feet; thence East 330 feet; thence North 3,300 feet to the point of beginning.

Section 32

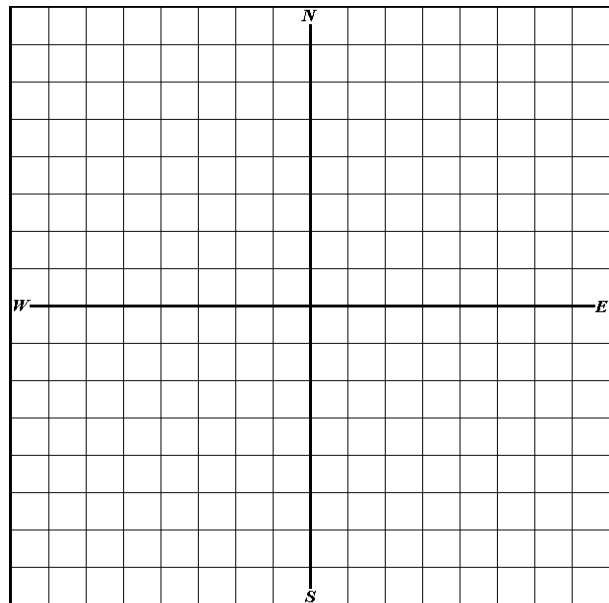

This parcel contains _____ acres.

Off and Off Of

Sometimes you will see “off” and “off of” in a legal description. If you read “165 ft. off of the N. side of Section 14”, you would begin at the north side of Section 14 and determine the distance to 165 ft. south of the northern border of Section 14. That would be the boundary line across the entire section.

When locating legal descriptions that are described by **linear measurement** (E10 chains off of the NW $\frac{1}{4}$ of the SE $\frac{1}{4}$), begin with the whole 640 acres of the section.

Step 1: Locate the NW $\frac{1}{4}$ of the SE $\frac{1}{4}$.

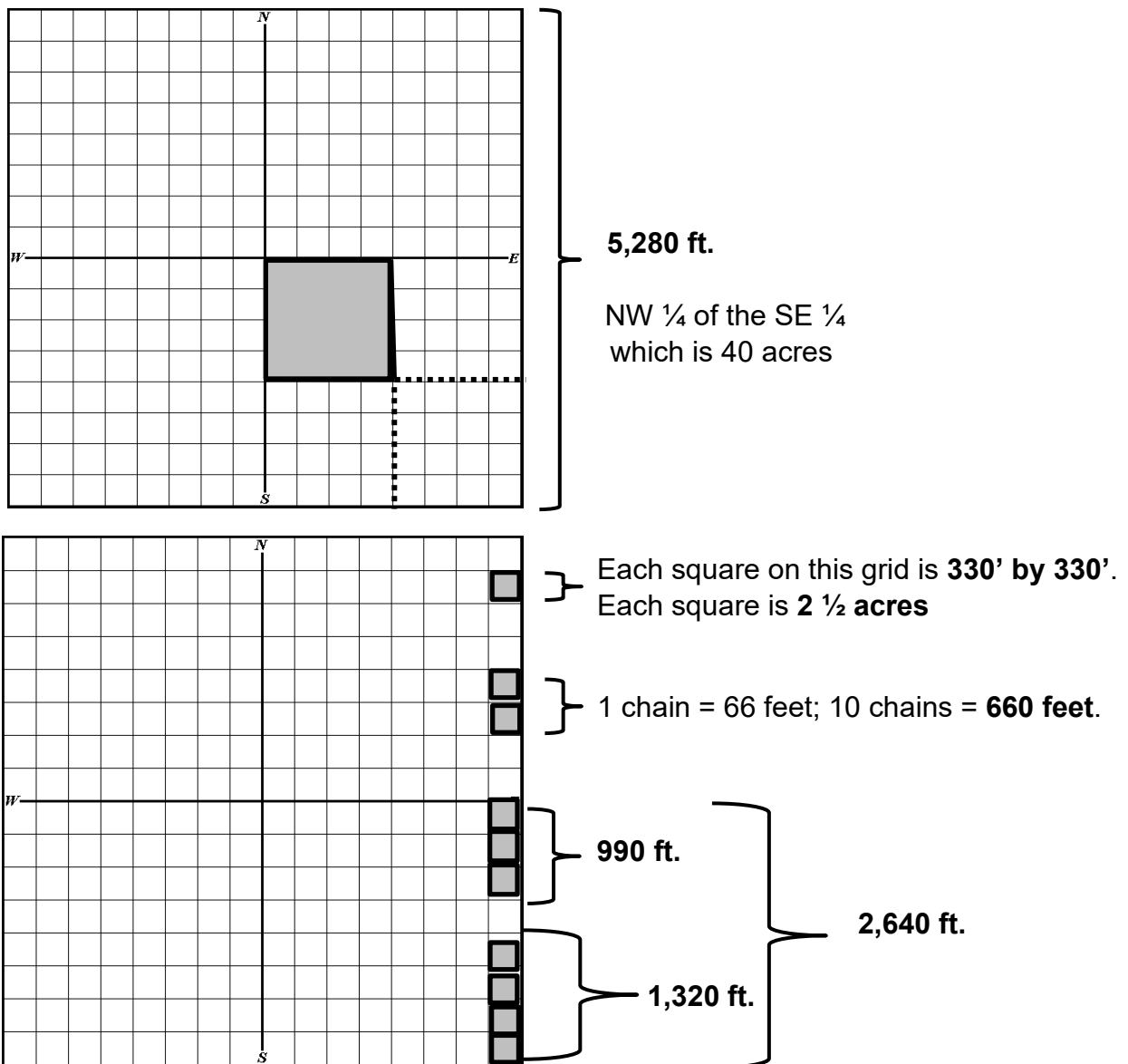

Step 2: Since the legal calls for the east 10 chains, locate the east side.

Step 3: Make a horizontal line from the NE corner, of the part that has already been identified, west 10 chains (660 feet).

Step 4: Make a horizontal line from the SE corner, of the part that has already been identified, west 10 chains (660 feet).

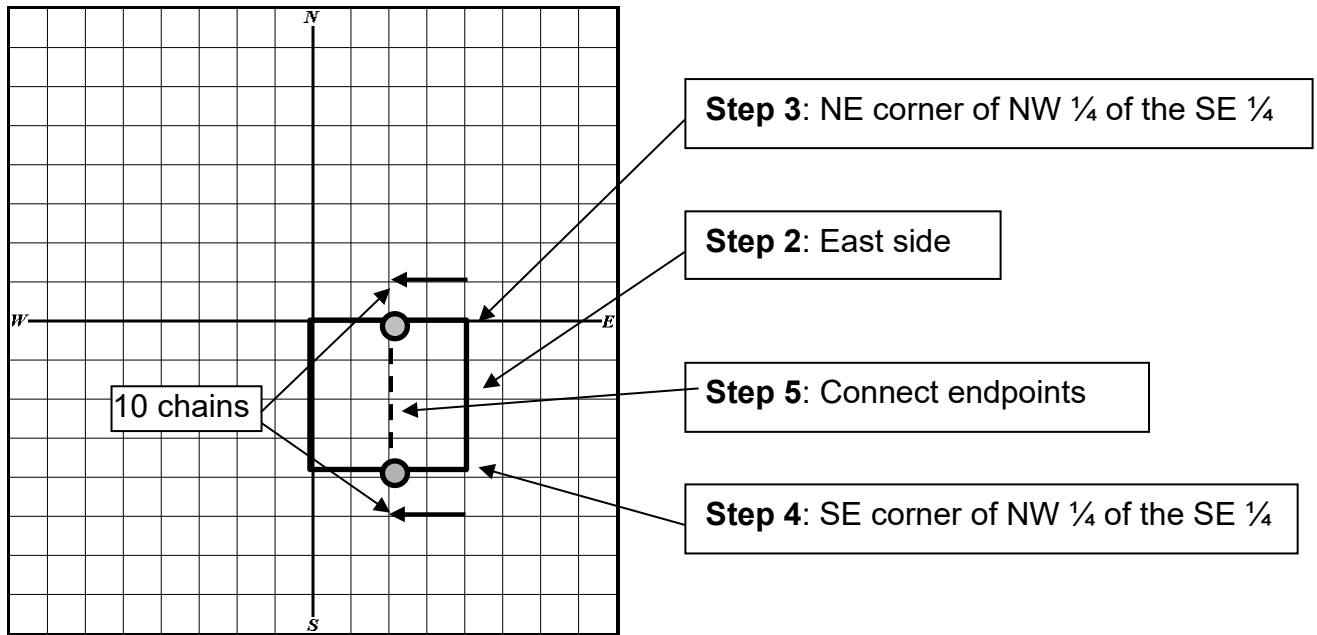

Step 5: Connect the endpoints of the lines representing the 10 chains to make a rectangle.

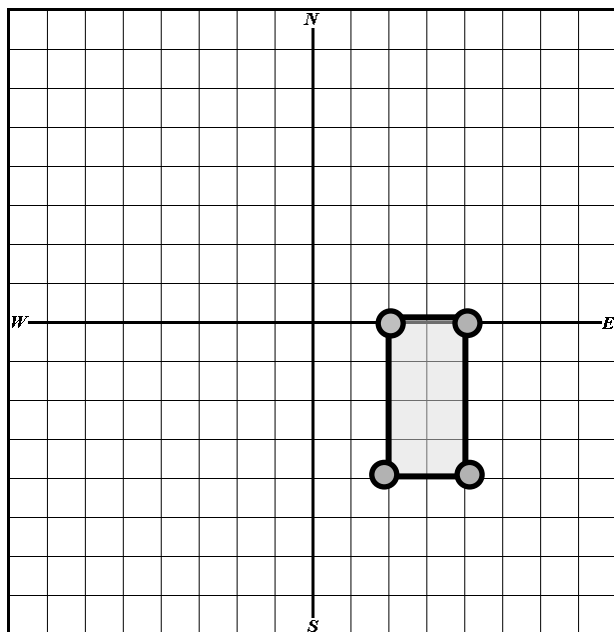

Unit 4, Exercise 4-6

Using **lineal** land measurement description methods, please locate the following parcels on the grid that follows, for Section 32, Township 12 South, Range 2 West, 3rd PM.

Refer to your template on Page 70 (or on your drafting triangle) for linear measurements.

1. The N 10 chains off of the NW $\frac{1}{4}$.
2. The W 330 ft. off of the SW $\frac{1}{4}$ of the SE $\frac{1}{4}$.
3. 82.5 ft. off of the S side of the NW $\frac{1}{4}$.
4. The East 330 ft. off of the E $\frac{1}{2}$ of the NW $\frac{1}{4}$ of the NE $\frac{1}{4}$.

Section 32 Grid Map- remember, a Section is One-Mile Square

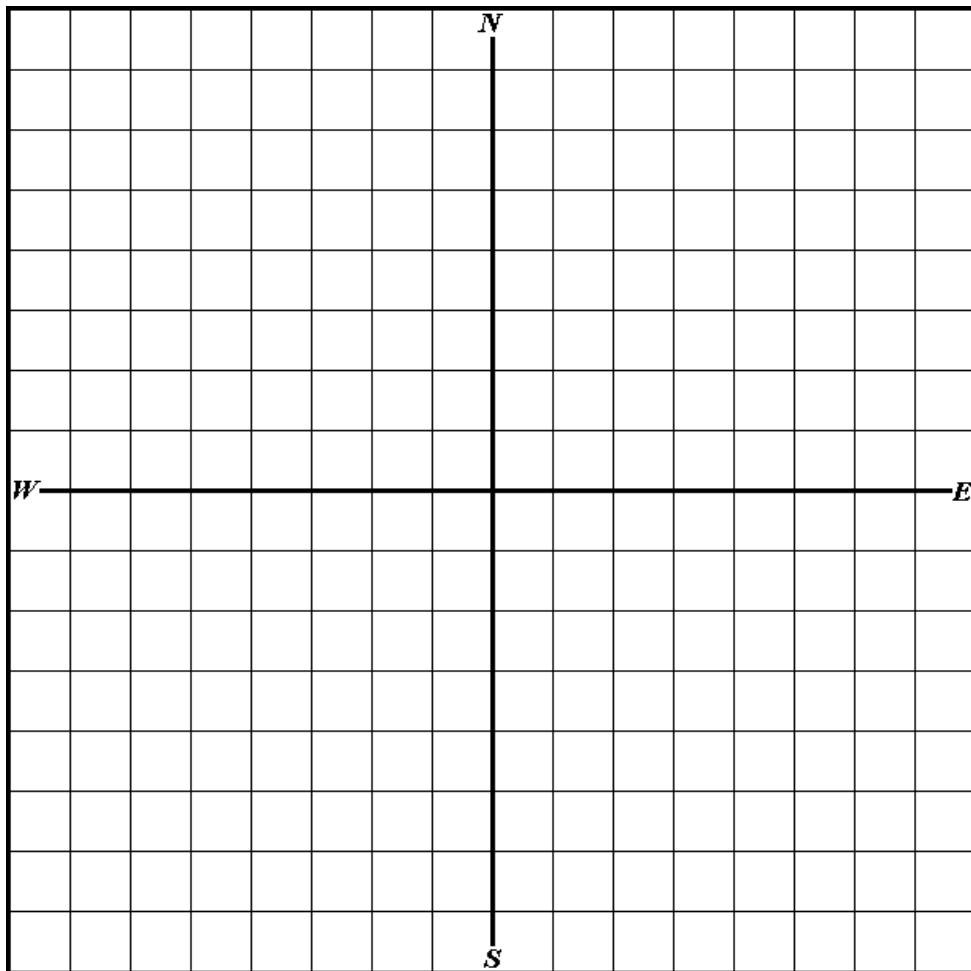

Combined Legal Descriptions

A single legal description can be determined even if the legal contains several different parcels. **In a legal description, the appearance of the words “and” or “also” and the semi-colon punctuation mark “;” all mean “in addition to”.** If these key words or the semi-colon appears, simply calculate the acreage for each parcel and then add the parcels together to determine the total acreage of the property described.

Unit 4 Exercise 4-7

In this exercise, you will measure the shapes in linear feet and then convert them into acreage. In addition, you will write the legal description describing the parcel.

Figure 1.
Section 14

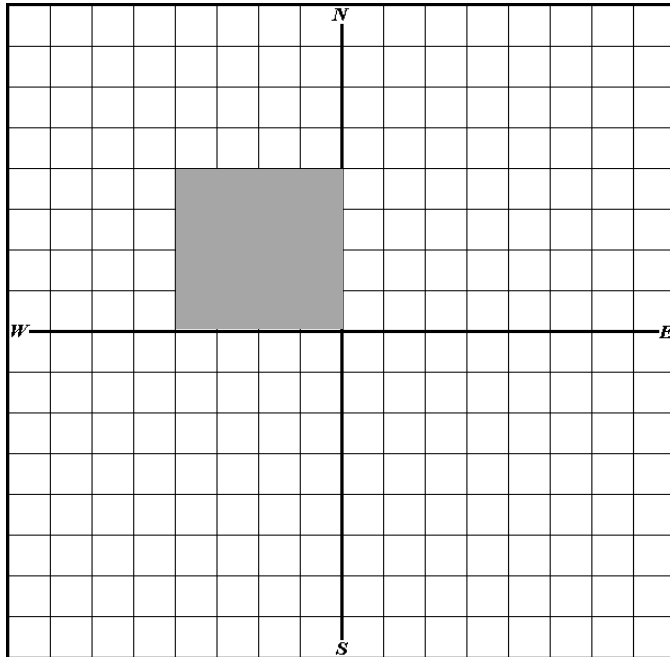

Linear measurements _____ feet X _____ feet.

Acreage calculation _____

Legal Description “Section 14, Township 9 North, Range 1 E of the 3rd Principal Meridian, _____

_____.

Figure 2.
Section 14

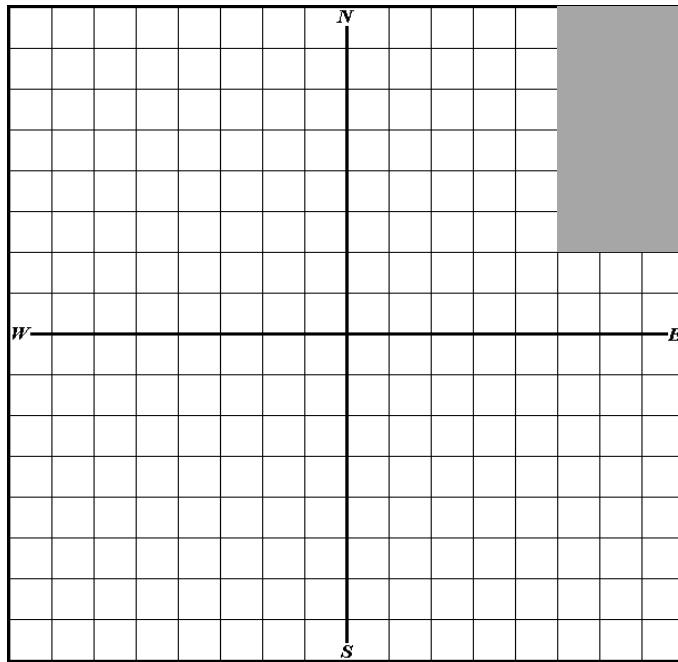

Linear measurements _____ feet X _____ feet.

Acreage calculation _____

Legal Description "Section 14, Township 9 North, Range 1 E of the 3rd Principal Meridian, _____

_____.

Unit 4 Summary

Legal descriptions describe the boundary and location of property. These descriptions can be

- land descriptions (which can be either fractional, acreage, or lineal), or
- lot-and-block descriptions,
- metes and bounds descriptions,
- or a combination of these.

When reading a legal description for purposes of locating property, read all legal descriptions not written in metes and bounds **backwards**.

If the description is written in metes and bounds, read the first part of the land description portion backward to locate the point of beginning. Once the point of beginning is determined, the metes and bounds portion of the description is read in the order written.

1 section = 640 acres
1/4 section = 160 acres
1/4 1/4 section = 40 acres
1/4 1/4 1/4 section = 10 acres
1/4 1/4 1/4 1/4 section = 2.5 acres
5,280 ft. = 1 mile
2,640 ft. = 1/2 mile
1,320 ft. = 1/4 mile
660 ft. = 1/8 mile

Unit 4 Review Questions

1. Locate the following on the following Section grid and calculate the acreage for each.

A. The NW $\frac{1}{4}$

D. 82.5 ft. off of the E side of the NE $\frac{1}{4}$

B. The SE $\frac{1}{4}$ of the SE $\frac{1}{4}$

E. The E 40 acres of the W 80 ac. of the NE $\frac{1}{4}$

C. The S 165 ft. off of the SW $\frac{1}{4}$

F. The North 10 chains off of the SE $\frac{1}{4}$

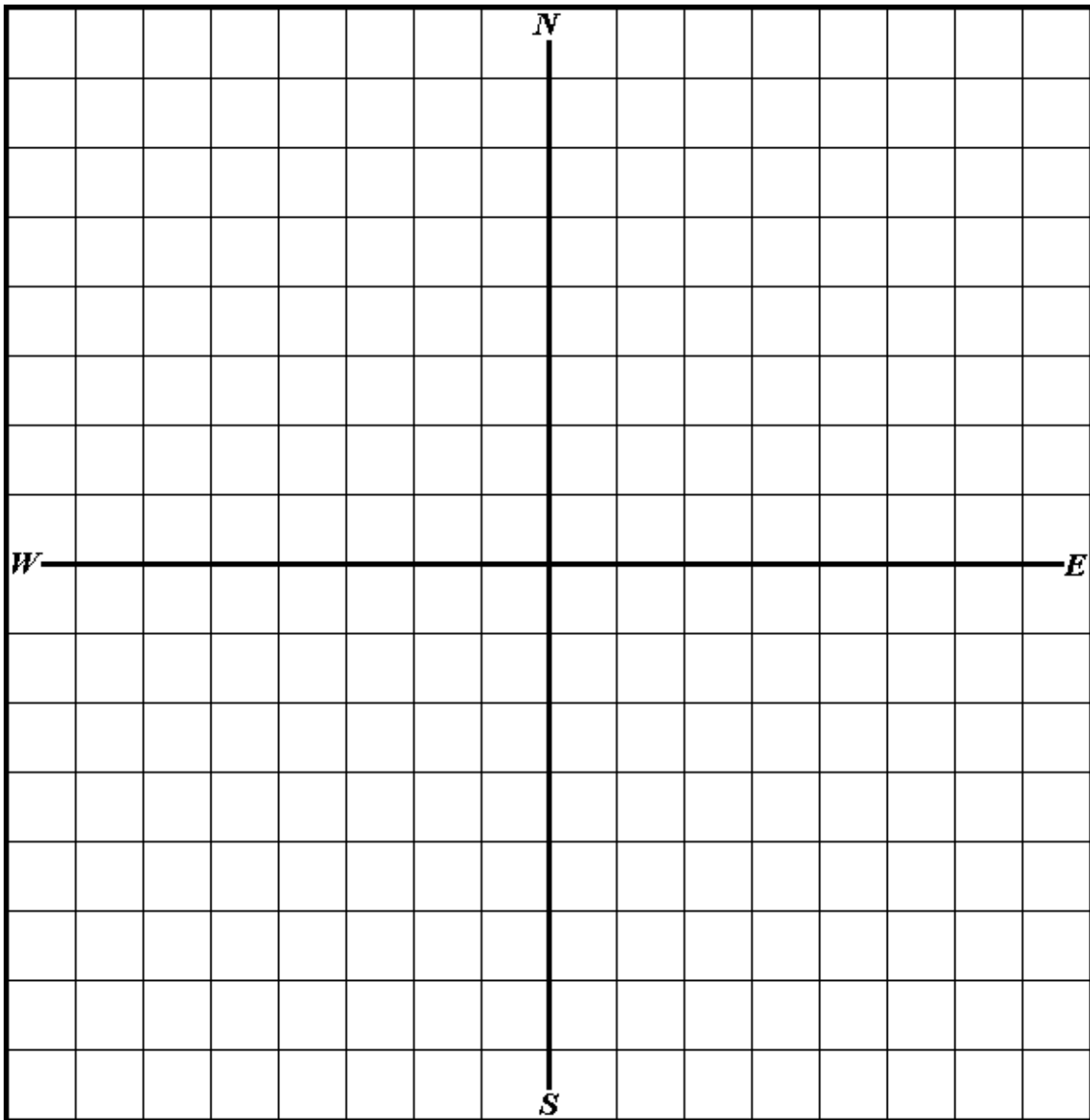

2. Calculate the acreage for the following.

a. The Northeast Quarter of the Northwest Quarter = _____ acres.

b. The SE 1/4 of the SE 1/4 of the SE 1/4 = _____ acres.

c. The East 1/2 of the Northwest Quarter of the Northeast Quarter = _____ acres.

3. To locate a parcel using a metes and bounds description, first read the land description portion of the legal description _____, and then read the metes and bounds portion of the description in the _____ written.

4. Read all legal descriptions not written in metes and bounds _____.

5. Write the legal description and calculate acreage below each section map:

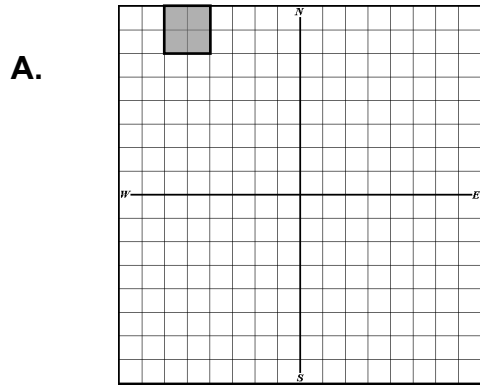

 _____ acres

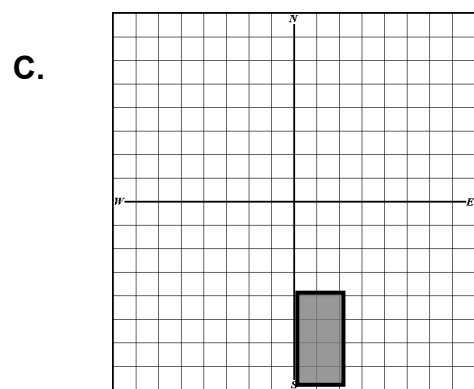

 _____ acres

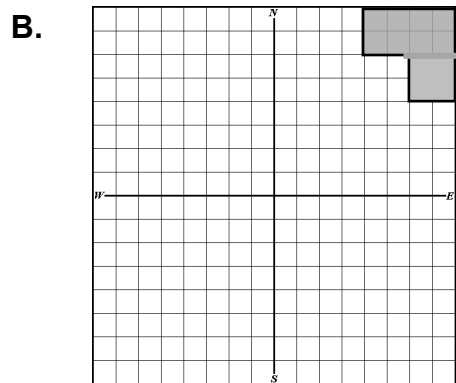

 _____ acres

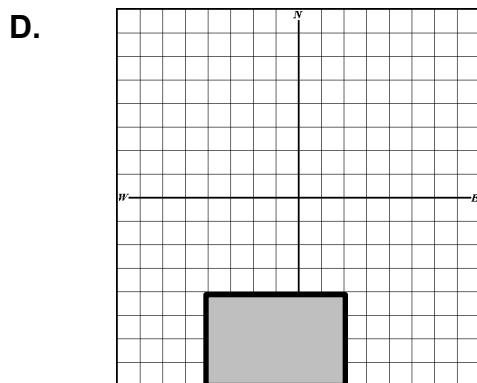

 _____ acres

6. Compute the acreage for the following parcel of land.

A part of the Southwest Quarter of Section 30, Township 11 South Range 1 East, of the Third Principal Meridian, described as follows: Commencing at the N.W. corner of the Southwest Quarter, thence running East 18 chains; thence running South 8 chains; thence East 5 chains; thence South 4 chains; thence West 23 Chains; thence North 12 chains to the point of beginning.

_____ acres, more or less.

The following pages have blank grids for additional practice.

Practice Pages

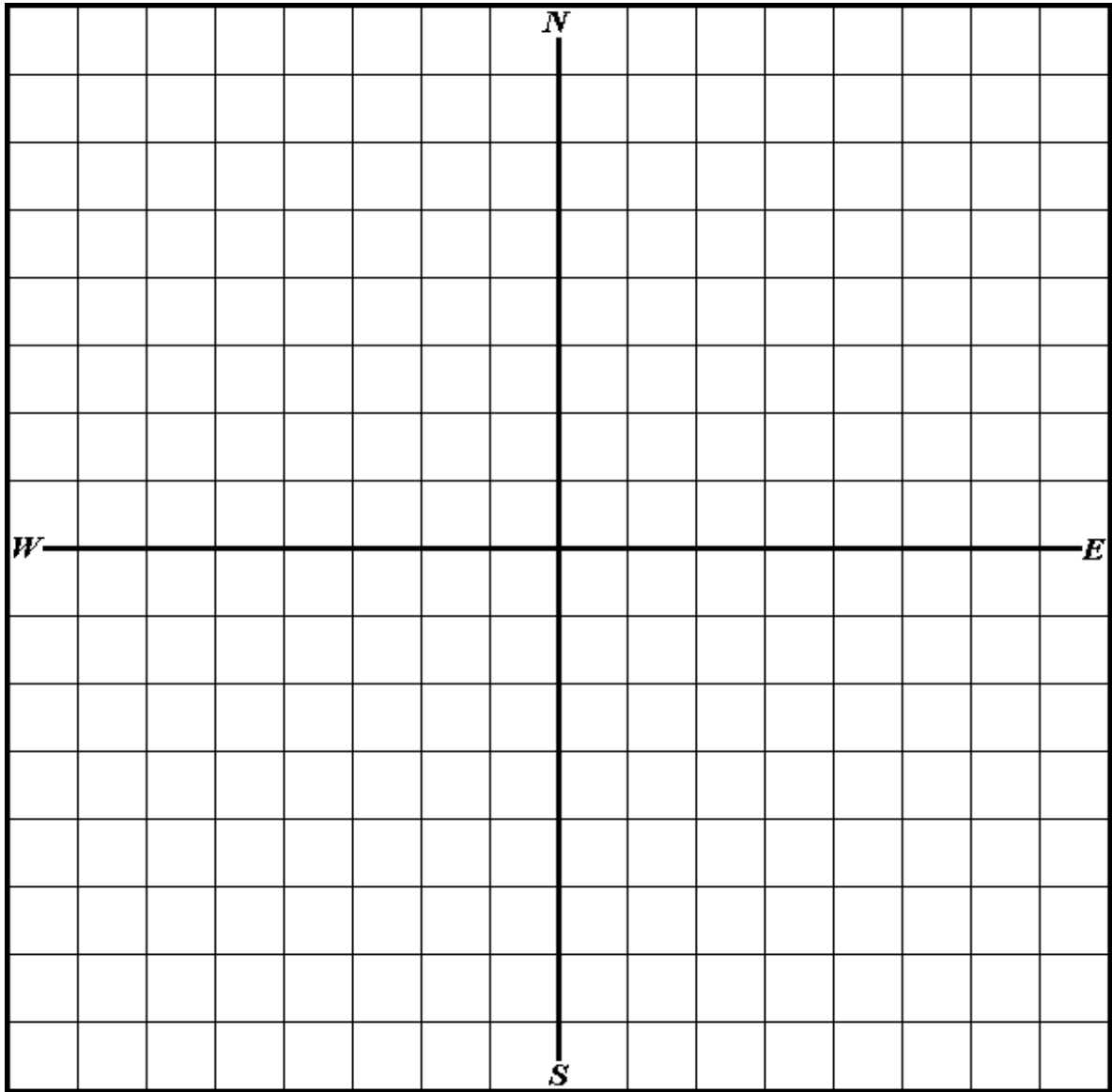

1 section = 640 acres
1/4 section = 160 acres
1/4 1/4 section = 40 acres
1/4 1/4 1/4 section = 10 acres
1/4 1/4 1/4 1/4 section = 2.5 acres
5,280 ft. = 1 mile
2,640 ft. = 1/2 mile
1,320 ft. = 1/4 mile
660 ft. = 1/8 mile

Practice Page

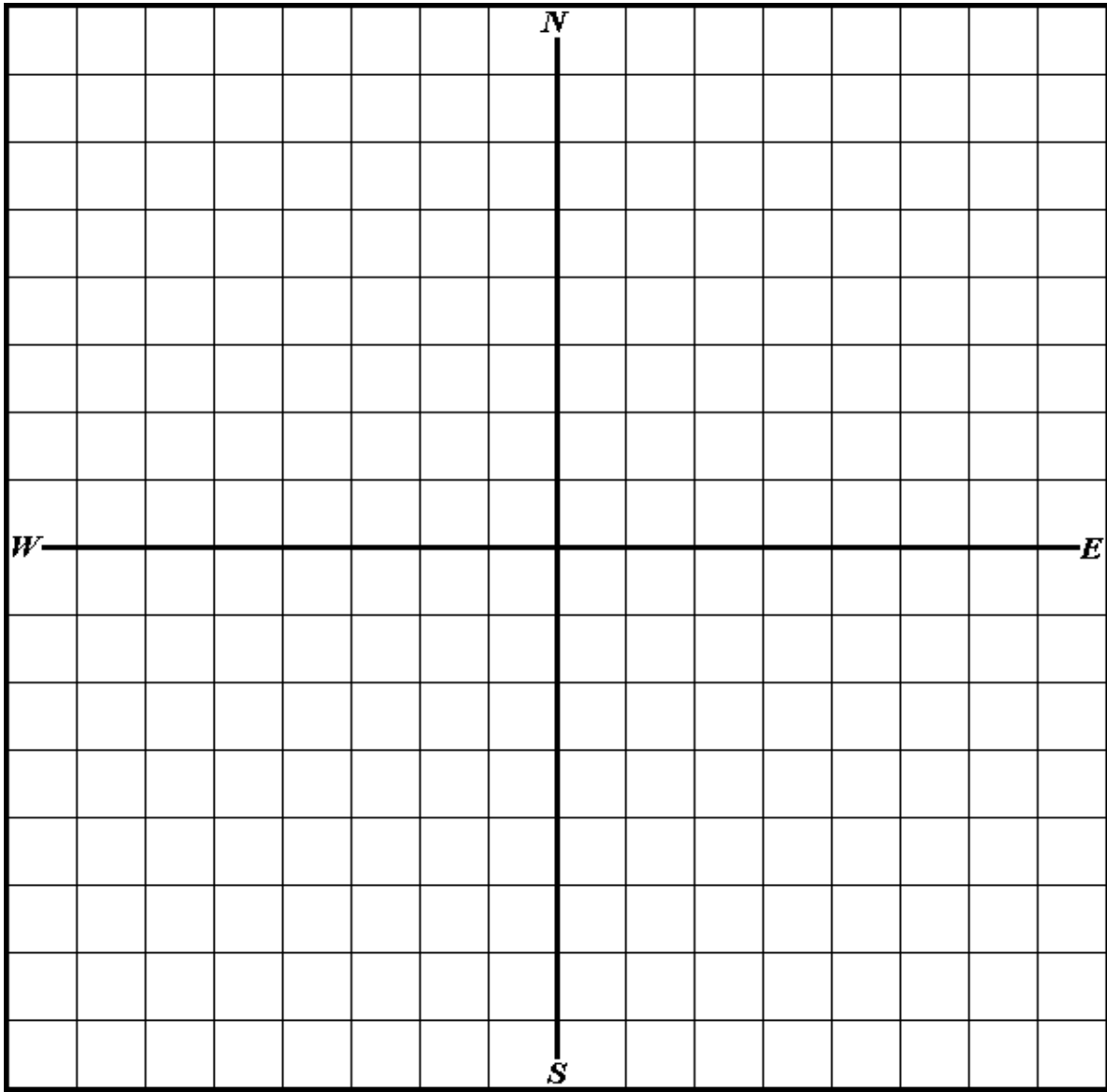

1 section = 640 acres
1/4 section = 160 acres
1/4 1/4 section = 40 acres
1/4 1/4 1/4 section = 10 acres
1/4 1/4 1/4 1/4 section = 2.5 acres
5,280 ft. = 1 mile
2,640 ft. = 1/2 mile
1,320 ft. = 1/4 mile
660 ft. = 1/8 mile

Practice Page

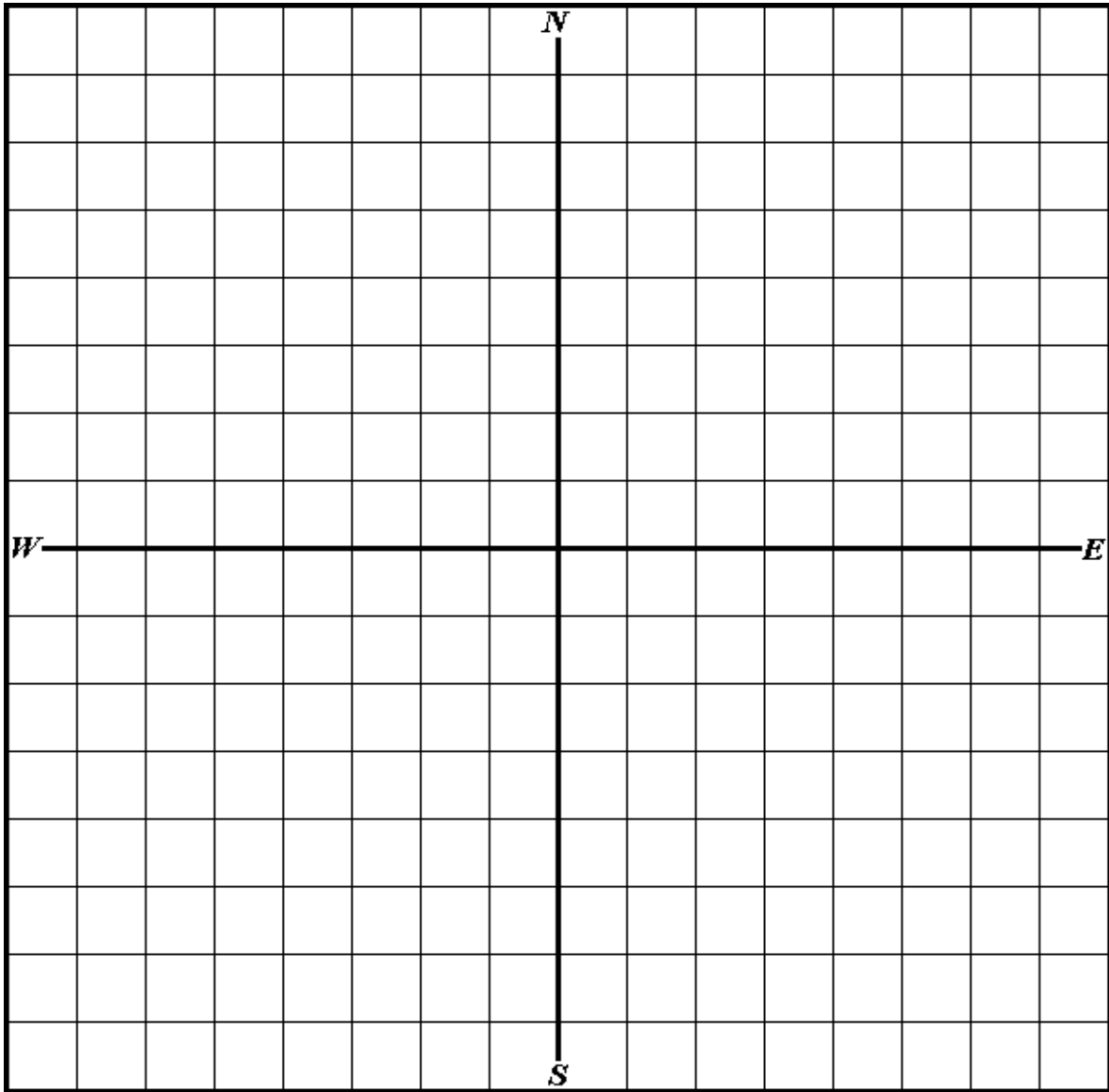

1 section = 640 acres
1/4 section = 160 acres
1/4 1/4 section = 40 acres
1/4 1/4 1/4 section = 10 acres
1/4 1/4 1/4 1/4 section = 2.5 acres
5,280 ft. = 1 mile
2,640 ft. = 1/2 mile
1,320 ft. = 1/4 mile
660 ft. = 1/8 mile

Unit 5 Metes and Bounds Legal Descriptions

Learning Objectives

After completing the assigned readings, you should be able to

- draw parcels from a metes and bounds legal description.
- understand map scale.
- use a land measure compass.

Terms and Concepts

Backsight

Bearing

Cardinal Directions

Commencing

Degree

Line

Metes and Bounds

Monuments

Point

Point of Beginning (POB)

Scale

Traverse

Introducing Your Tools

For the drawing portions of this course, training and directions will be given based on the assumption that the tools identified below, or something similar, are being used.

Drawing legal descriptions can, however, be accomplished with other tools, such as protractors and rulers. **The following drawing tools will be supplied for you for the exam, or you may use your own drawing tools.**

Land Measure Compass

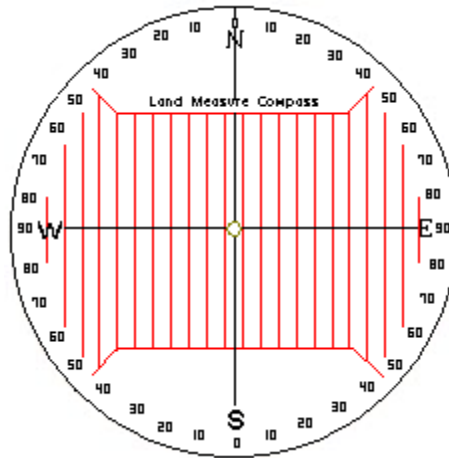

The land measure compass is designed to draw **metes and bounds** legal descriptions.

Drafting Triangle

The drafting triangle is a typical right-angle triangle except that it includes helpful information. Right triangles are needed to keep parcel drawings square. In addition, the triangle helps identify which angles are right angles.

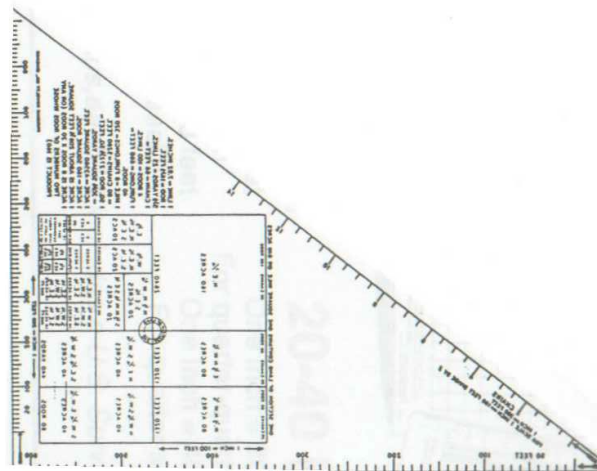
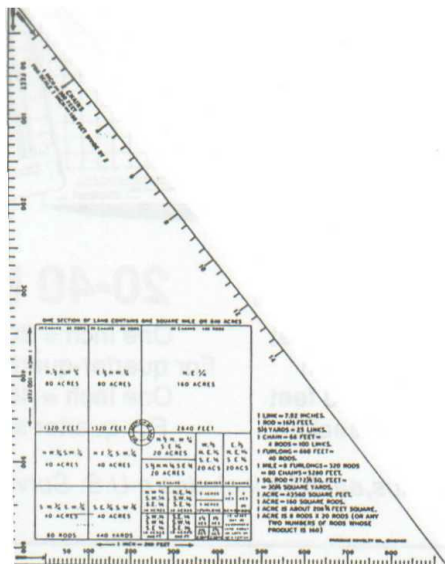

Drafting Scale

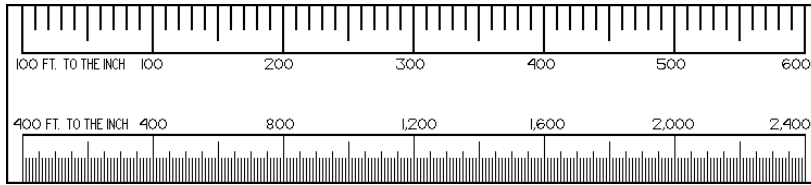

Drafting scales come in various forms and various divisions. Depending on the size of the parcel and the size of the paper, different scales can be used. For example, if a parcel is to be drawn on a sheet of paper that is 8 ½ x 11, and the longest line of the parcel is 1,320 feet, a scale of 1" = 100' could not be used because that would result in the longest line being 13.2 inches long. Therefore, it is important to review the legal description and determine the size of the map before selecting the scale at which the map will be drawn.

Using your Tools

How to Convert Distances to Map Scale

As described above, it is important to understand map scale. You must convert property line distances on the ground into the map scale on your paper to represent the line appropriately on the map. Use a mathematical conversion in which you

Divide the Legal Description Measurement by the Map Scale.

For instance, if the paper to map scale is 1" = 100', 1 inch on the map equals 100 feet on the ground.

Example: Travel west for 595 feet on a map with a scale of 1" = 100'

$$595 \div 100 = 5.95$$

This means that your 595 feet long line on a map with a map scale of 1" = 100', will equal a line 5.95 inches long.

This method is also necessary when the map scale is different than the map scale of your legal description. For example, historic maps were drawn at a scale of 1" = 660'. The only way to draw legal description measurements on a map is with a ruler or scale. So, using the conversion method above:

$$595 \text{ ft.} \div 660 = .90 \text{ inches}$$

This line on a map with a scale of 1" = 660" will be slightly less than an inch long.

Unit 5, Exercise 5-1 Map Scale Conversions

<u>Map Scale</u>	<u>Ground Distance</u>	<u>Length of Line on Map</u>
1. 1:100	330 ft.	_____
2. 1:400	2,640 ft.	_____
3. 1:600	5,280 ft.	_____
4. 1:660	5,280 ft.	_____
5. 1:660	1,320 ft.	_____
6. 1:200	675 ft.	_____

Metes and Bounds Descriptions

As discussed in the previous chapter, **metes and bounds** descriptions are used to **describe the perimeter of property**. Beginning at a point (located using the rectangular survey system), metes and bounds descriptions are read forwards, traversing from point to point until the entire property has been circumscribed, returning at the **point of beginning (POB)**. In metes and bounds descriptions “commencing”, “beginning at”, and “point of beginning” are all terms used to describe the starting point for the metes and bounds description.

Within a metes and bounds description, the **bearings** and distances of each **traverse** are listed.

A **Bearing** is the direction of a line measured as the acute angle from a reference meridian.

A **Traverse** is the length (distance) and direction (bearing) of a line drawn between two points.

An **Acute Angle** is an angle less than 90°.

Therefore, in a metes and bounds description, a typical traverse could look something like: North 45° West, for 595 feet. Using the land measure compass, starting at North 0°, move 45° counter-clockwise, which is west. This would be the bearing. The distance from Point A to Point B in this example is 595 feet. A traverse includes a bearing and a distance.

Land Compass Bearings

Line up your land compass on the following diagram. The north and south arrows should indicate 0° . The east and west arrows should indicate 90° . If a legal description calls for a line North 45° West, you would first start with the North 0° point on your compass, then move along the compass to the west (your left), until you reach 45° . Your bearing would be the line of the arrow marked NW. If a legal description calls for a line South 45° East, you would first start with the South 0° point on your compass. Then move along the compass to the east (your right) until you reach 45° . Your point would be the line of the arrow marked SE. This would be your bearing.

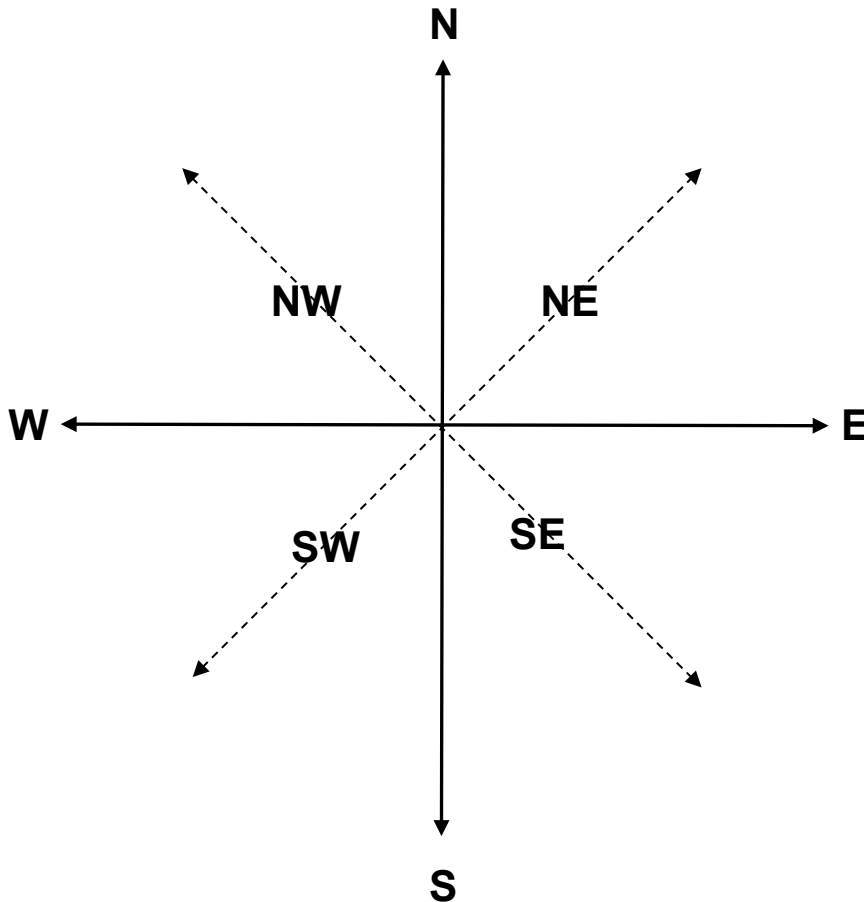

Note: North, South, East, West, Northeast, Northwest, Southeast, Southwest are known as Cardinal Directions.

Describing and Measuring a Parcel

Here is a practice example in measuring a metes and bounds parcel. Remove the following page from your packet and trace the following drawing from the Point of Beginning and label all bearings and traverses. We will do this exercise together as a class.

You can orient your drawing two ways:

1. Use the red vertical lines on your land compass to line up with the long edge of your paper or
2. Use your drafting triangle and align one of the right-angle sides with the edge of the paper to get a good horizontal reference point to align the compass

Point of Beginning

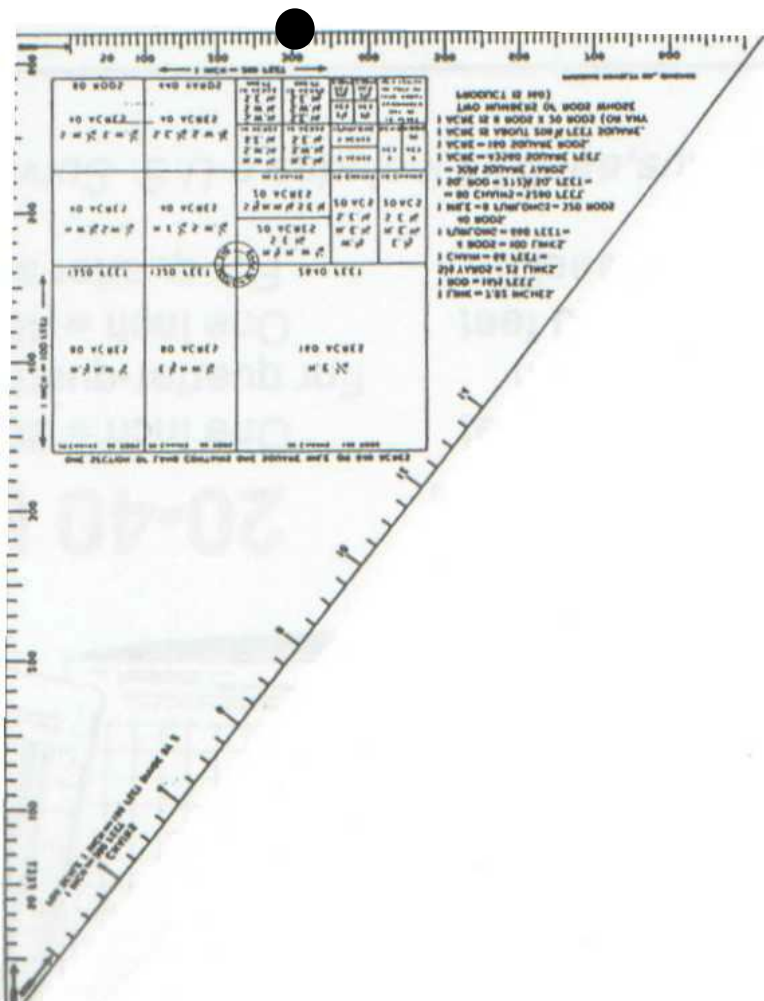

Point of Beginning

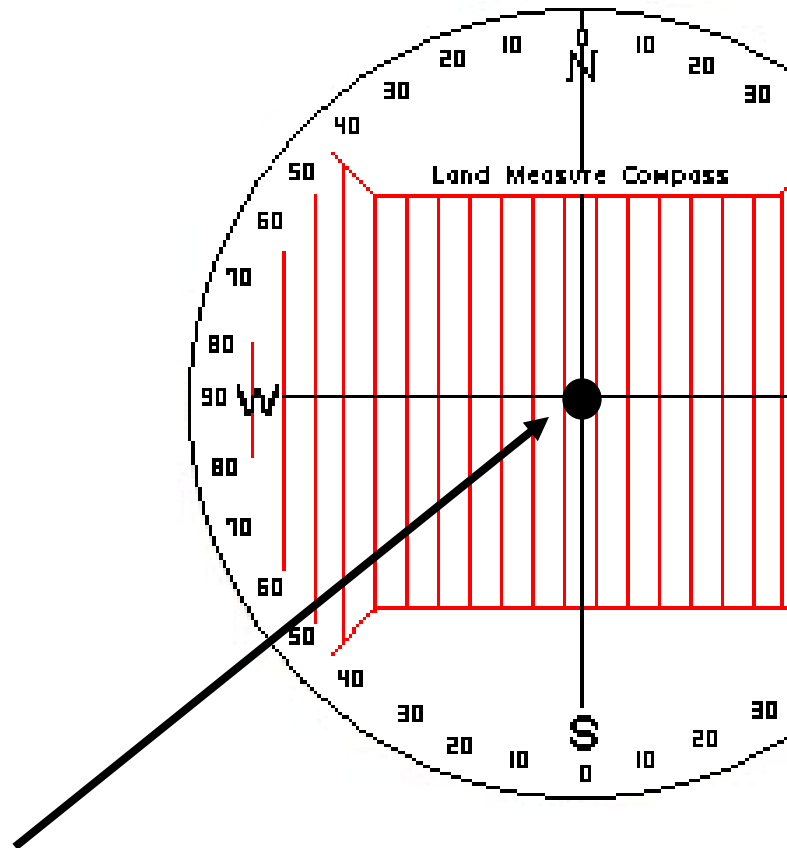

Please Remove this sheet from your binder. We will use this as a template to learn to use the mapping tools.

Point of Beginning

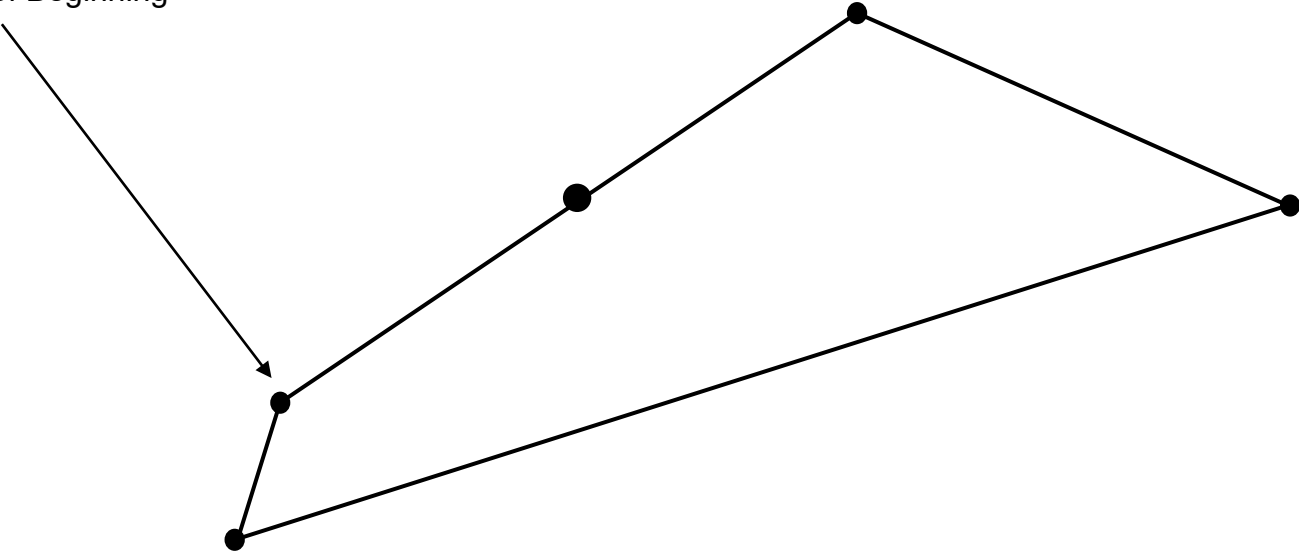

Step 1: Place the land measure compass on top of the point of beginning (POB) so that the center hole of the compass is directly over the POB and North (N) is up. Line up one of the red vertical lines on the compass with the left-hand edge of the paper to first orient the compass or use the two adjacent sides that make up the right angle of the drafting triangle to orient the compass as shown on page 102.

Point of Beginning

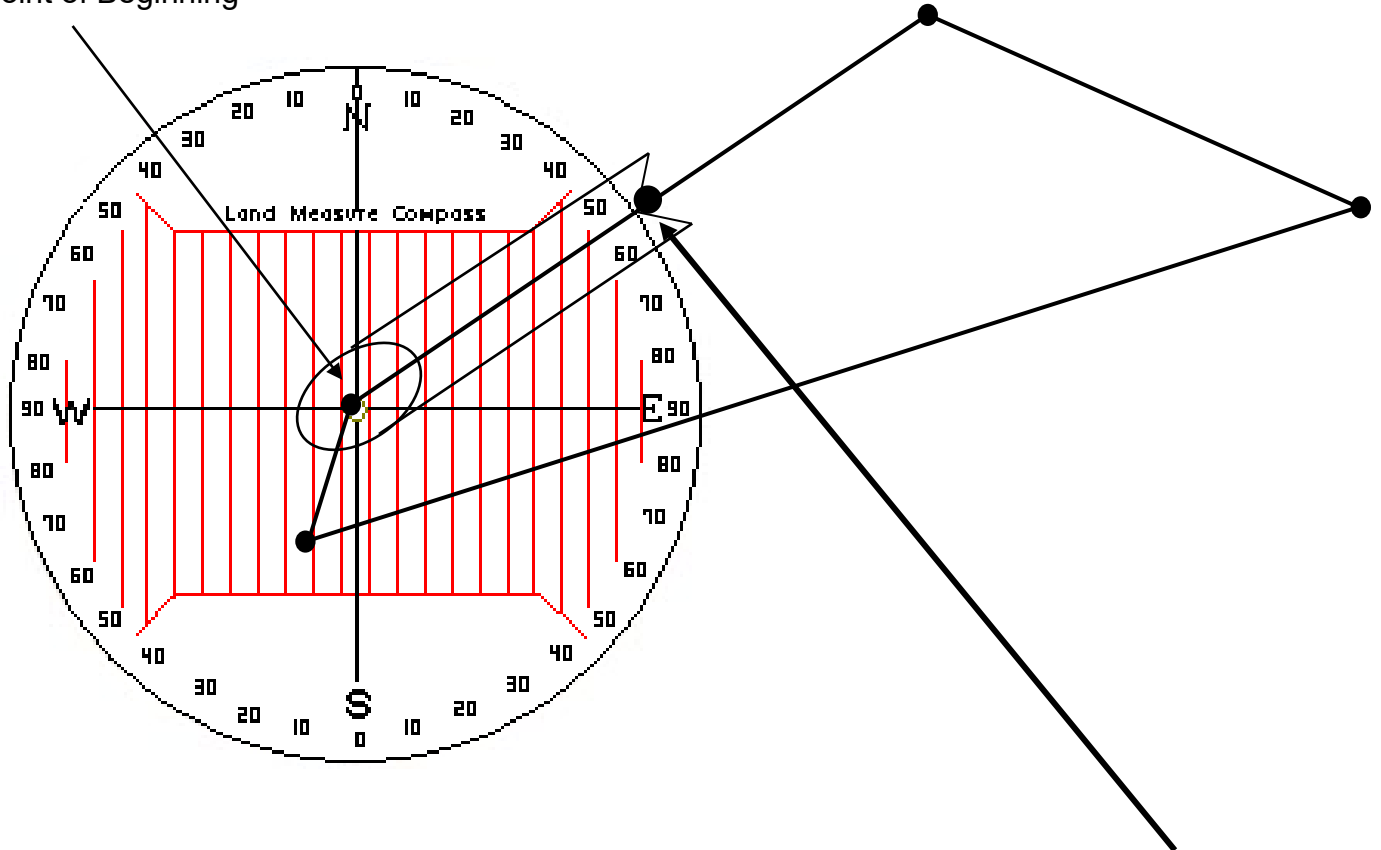

Step 2: Move the arm on the land compass to line up exactly over the first line (that is already labeled to North 55° East). There is a notch on the movable arm on the compass to fit your pen or pencil in to make a dot. Make that dot.

Use your map scale 1:200 for this exercise

Step 3: Remove the land measure compass, and using a drafting scale (your ruler), place the “0” on the POB, and line up the scale with the mark made at the **N 55° E bearing**. Then follow the line that represents 700'. With a map scale of 1" = 200', that would be a line that is 3.5 inches long (number of feet divided by the map scale = $700/200 = 3.5$ inches to Point A). Line up your drafting scale at the POB and measure 700 feet on the 1:200 side of your scale. Mark this point with a bigger dot and label it Point A. This line may be longer or shorter than the location of the dot you made at the end of the moveable arm on your compass.

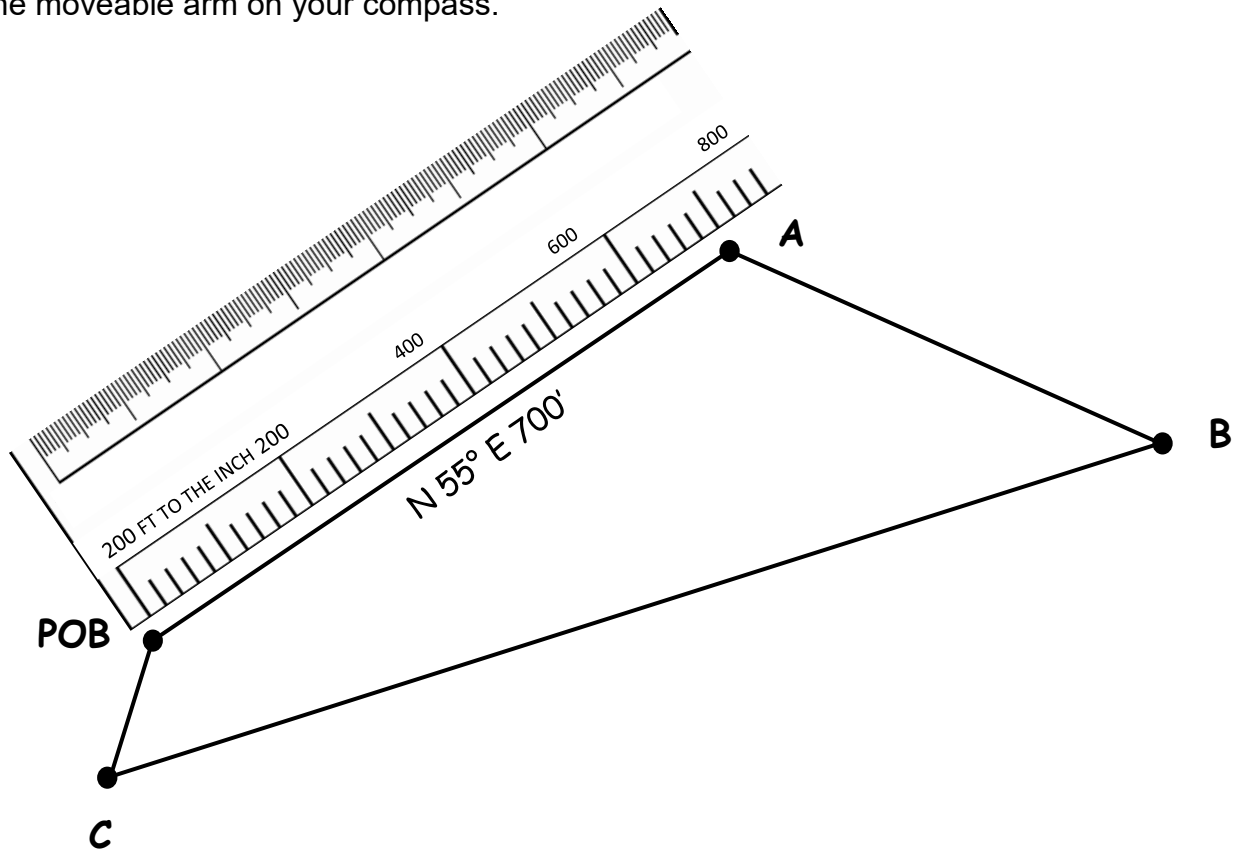

Step 4: It is recommended that each line should be labeled with both bearings and distances (traverse) as it is drawn, so that if a problem is discovered the information from the legal description is right there on the drawing. The mark you made at N 55° E only gives the direction (bearing) of the line. The drafting scale shows the length of the line.

The line will be labeled **N 55° E 700'**.

Step 5: Place the land measure compass on top of Point A, ready for the next measurement in the legal description. At this point, it is important to be sure that the land measure compass is oriented on the page the same way as it was when beginning the drawing. Otherwise, even a small twist in the compass could have dramatic effects.

To avoid this problem, **backsighting** is used.

A backsight is defined as “reading taken by a surveyor back toward a position from which a previous sight has been made”. On the land measure compass, **the backsight is the opposite of the bearing previously used**. Since the previous bearing was **N 55° E**, the backsight is **S 55° W**. So, orienting the land measure compass on the map with the center over Point A, and the line drawn matching up with S 55° W indicates that the compass is now sitting on the page the same way as when the drawing began.

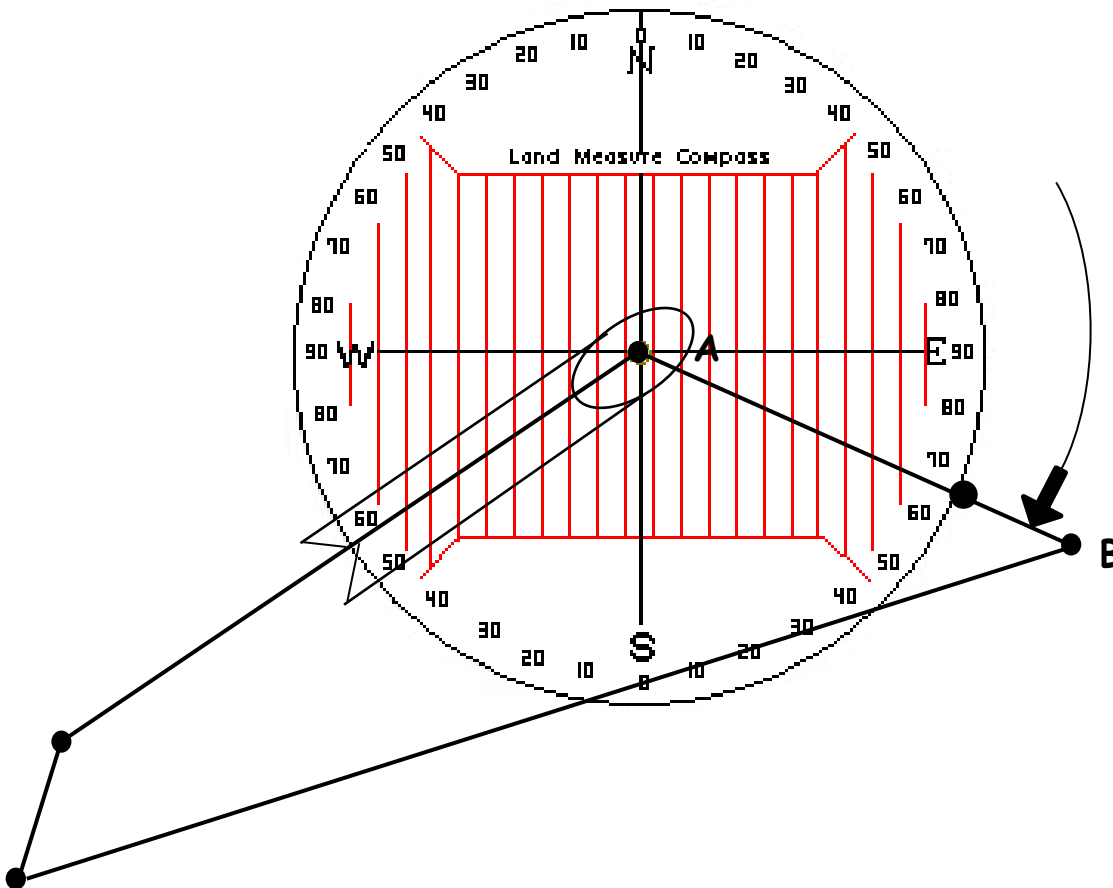

Now, with Point A in the center use your land compass to determine the degree-measurement of the line adjoining Point A with Point B. Now measure the length of the line. Label the line. Continue orienting the compass and backsighting from each point and measure each line and angle and label for lines B-C & C-POB.

The measurements should be: A-B = S 68° E 475 ft.
 B-C = S 71° W 1100 ft.
 C-POB = N 17° E 175 ft.

If your measurements differ greatly, you may not have oriented the compass correctly!

Drawing Legal Descriptions

In the last exercise, we measured an existing parcel shape. Now you will learn how to draw the parcel by reading the legal description

This is a practice example in drawing a metes and bounds legal description. Follow along by tracing over the diagram using the legal description accompanying the drawing.

Step 1: Place the land measure compass on top of the point of beginning (POB) so that the center hole of the compass is directly over the POB and North (N) is up. Line up one of the red vertical lines with the left-hand edge of the paper to first orient the compass or use the two adjacent sides that make up the right angle of the triangle to orient the compass.

Use a map scale of 1:100 for this exercise.

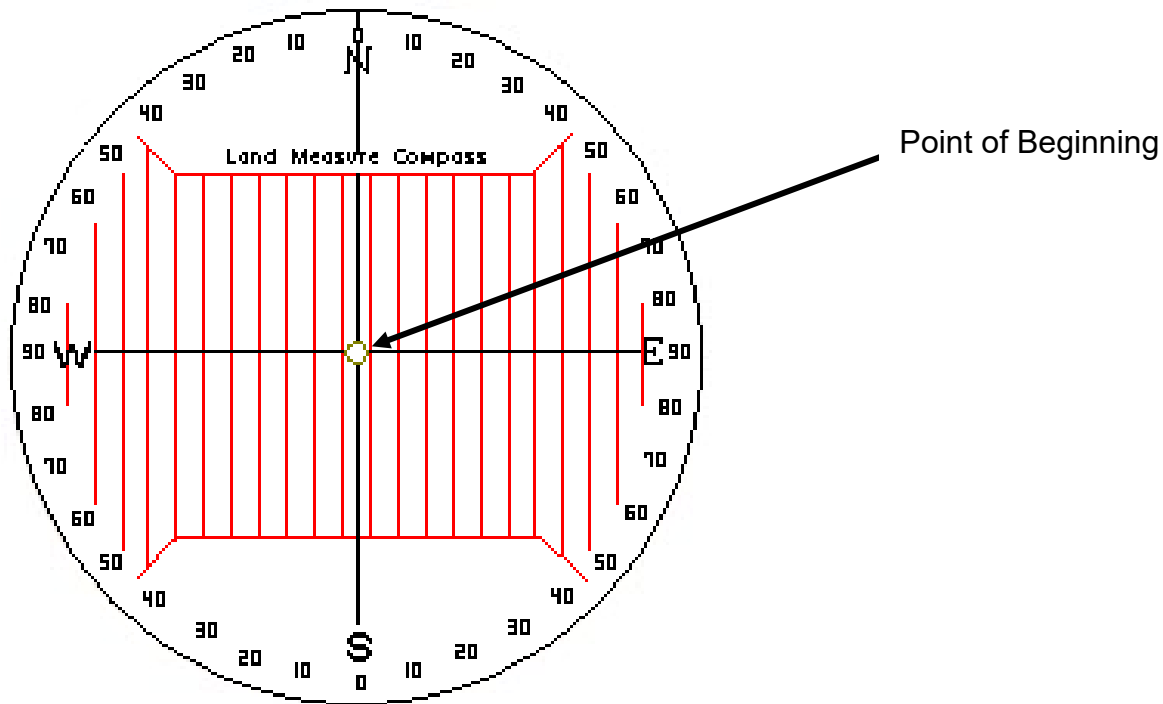

Step 2: Reading the first measurement of the legal description, (N 80° E, 350'), make a mark on the paper at N 80° E. There is a notch on the movable arm on the compass to fit your pen or pencil in to make a dot.

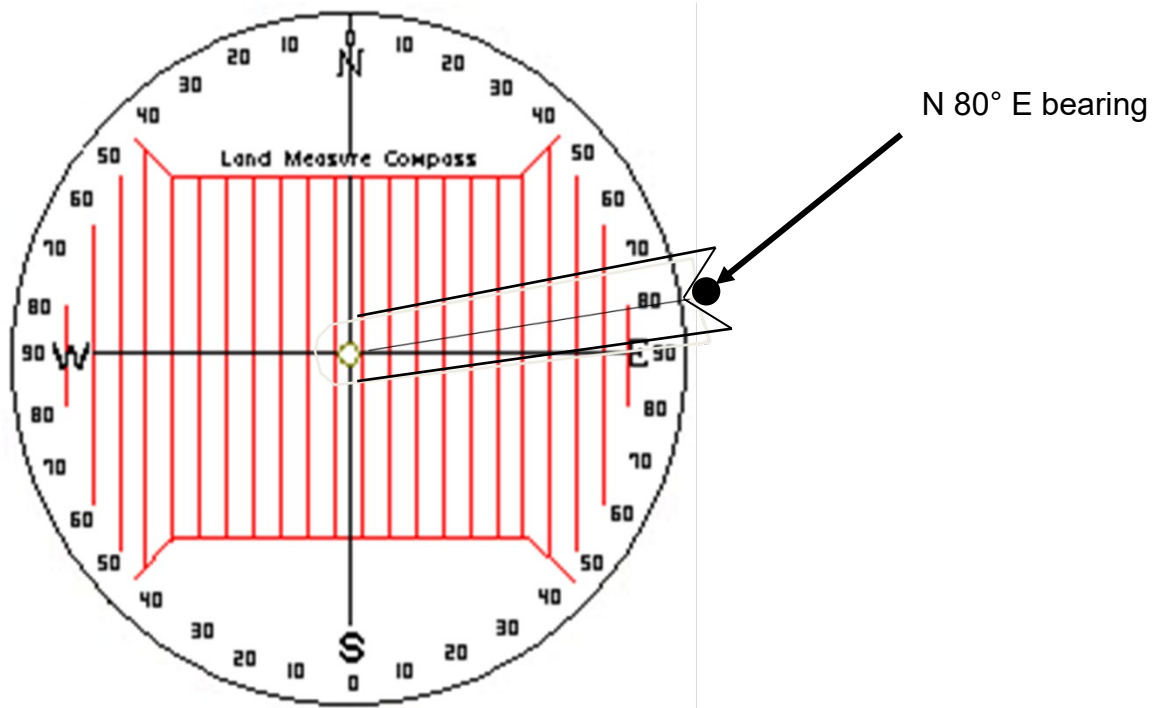

Step 3: Remove the land measure compass, and using a drafting scale (your ruler), place the "0" on the POB, and line up the scale with the mark made at the N 80° E bearing. Then draw a line that represents 350'. **With a map scale of 1" = 100'**, that would be a line that is 3.5 inches long (to Point A). This line may be longer or shorter than the location of the dot you made at the end of the moveable arm on your compass. The mark you made at N 80° E only gives the direction (bearing) of the line. The drafting scale shows the length of the line.

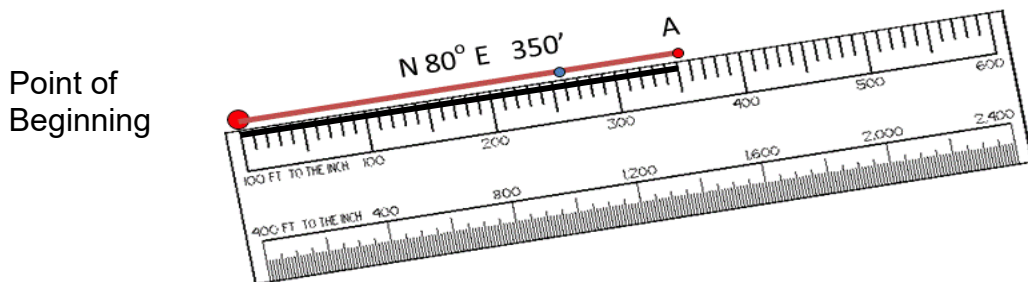

Step 4: It is recommended that each line should be labeled with both bearings and distances (traverse) as it is drawn, so that if a problem is discovered the information from the legal description is right there on the drawing.

Step 5: Place the land measure compass on top of Point A, ready for the next measurement in the legal description. The next step is to **backsight**.

Remember, a backsight is the opposite of the bearing previously used. Since the previous bearing was **N 80° E**, the backsight is **S 80° W**. So, orienting the land measure compass on the map with the center over Point A, and the line drawn matching up with S 80° W indicates that the compass is now sitting on the page the same way as when the drawing began.

Without moving the land measure compass, make a mark on the map using the second bearing (S 45° E). This time look at due South. Make the mark that is 45° East (counter-clockwise) of South.

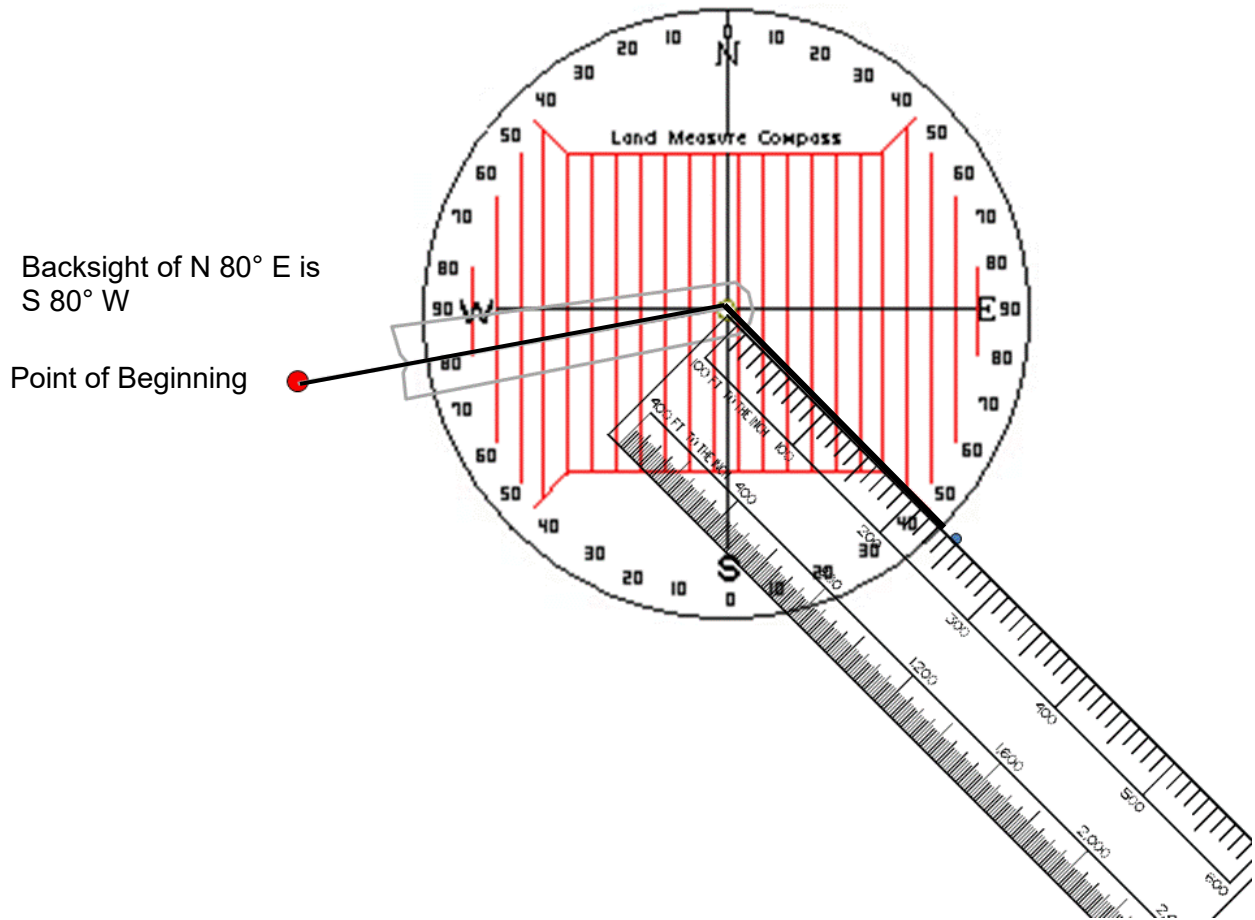

Step 6: Remove the land measure compass, and using a drafting scale, place the “0” mark on Point A, and line up the scale with the mark made at the S 45°E bearing. Then draw a line that represents 250'. With a map scale of 1" =100', that would be a line that is 2.5 inches long (to Point B).

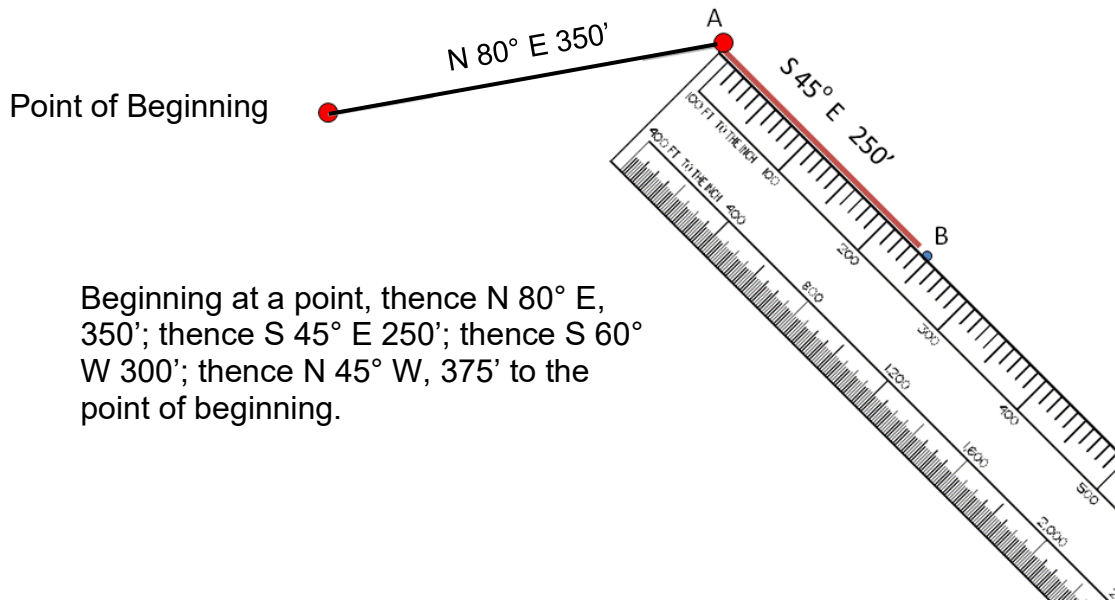

Beginning at a point, thence N 80° E, 350'; thence S 45° E 250'; thence S 60° W 300'; thence N 45° W, 375' to the point of beginning.

Step 7: Place the land measure compass on top of Point B. Backsight the previous line to be sure the compass is oriented correctly. The previous bearing was S 45°E, therefore the backsight is N 45°W. Turn the land measure compass until the last line drawn lines up with N 45°W.

Step 8: Without moving the land measure compass, make a mark on the map using the third bearing (S 60°W).

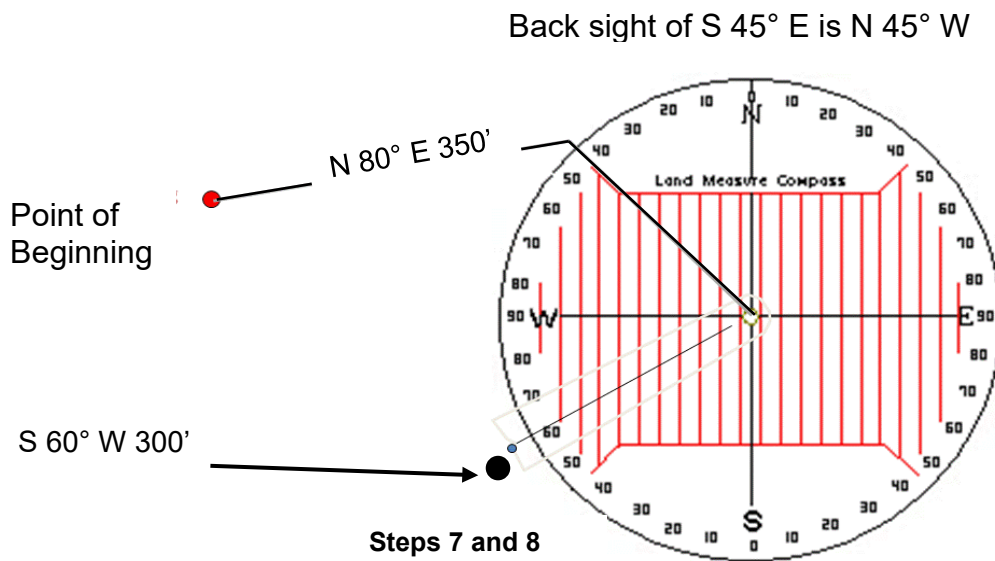

Step 9: Remove the land measure compass, and using a drafting scale, place the “300” on Point B, and line up the scale with the mark made at the S 60° W bearing. Then draw a line that represents 300'. With a map scale of 1" =100', that would be a line that is 3.0 inches long (to Point C).

Beginning at a point, thence N 80° E, 350'; thence S 45° E 250'; thence S 60° W 300'; thence N 45° W, 375' to the point of beginning.

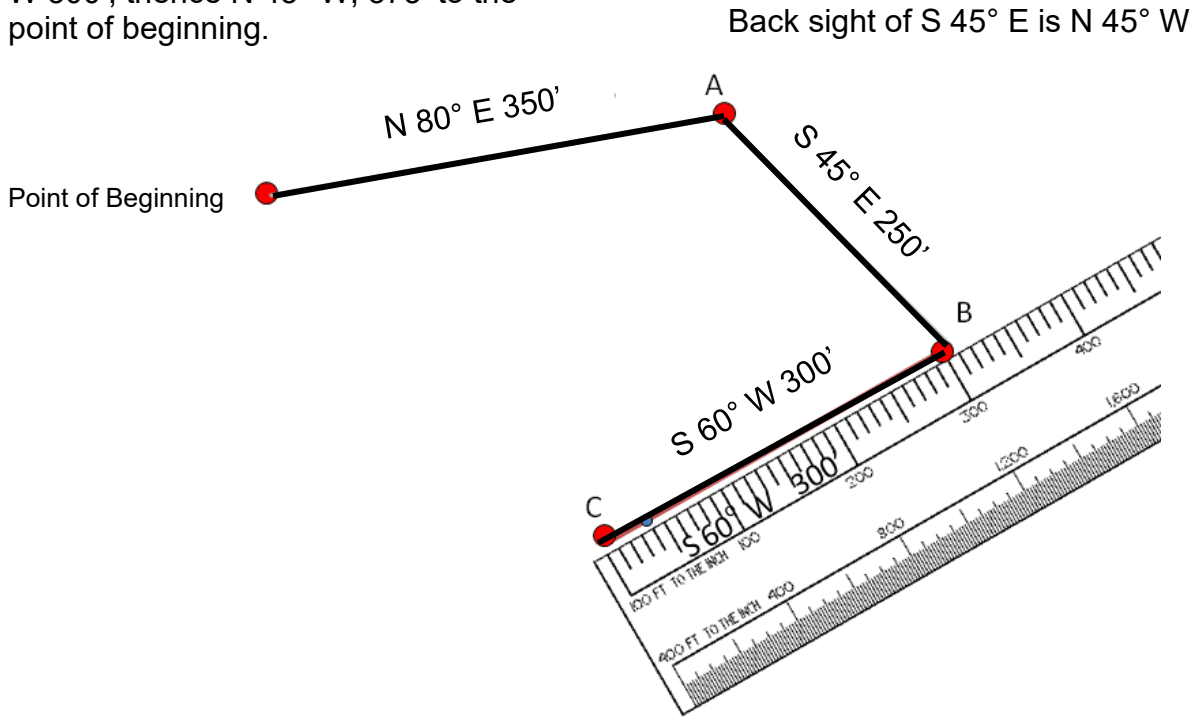

Step 10: Place the land measure compass on top of Point C. Backsight the previous line to be sure the compass is oriented correctly. The previous bearing was S 60° W, therefore the backsight is N 60° E. Turn the land measure compass until the last line drawn lines up with N 60° E.

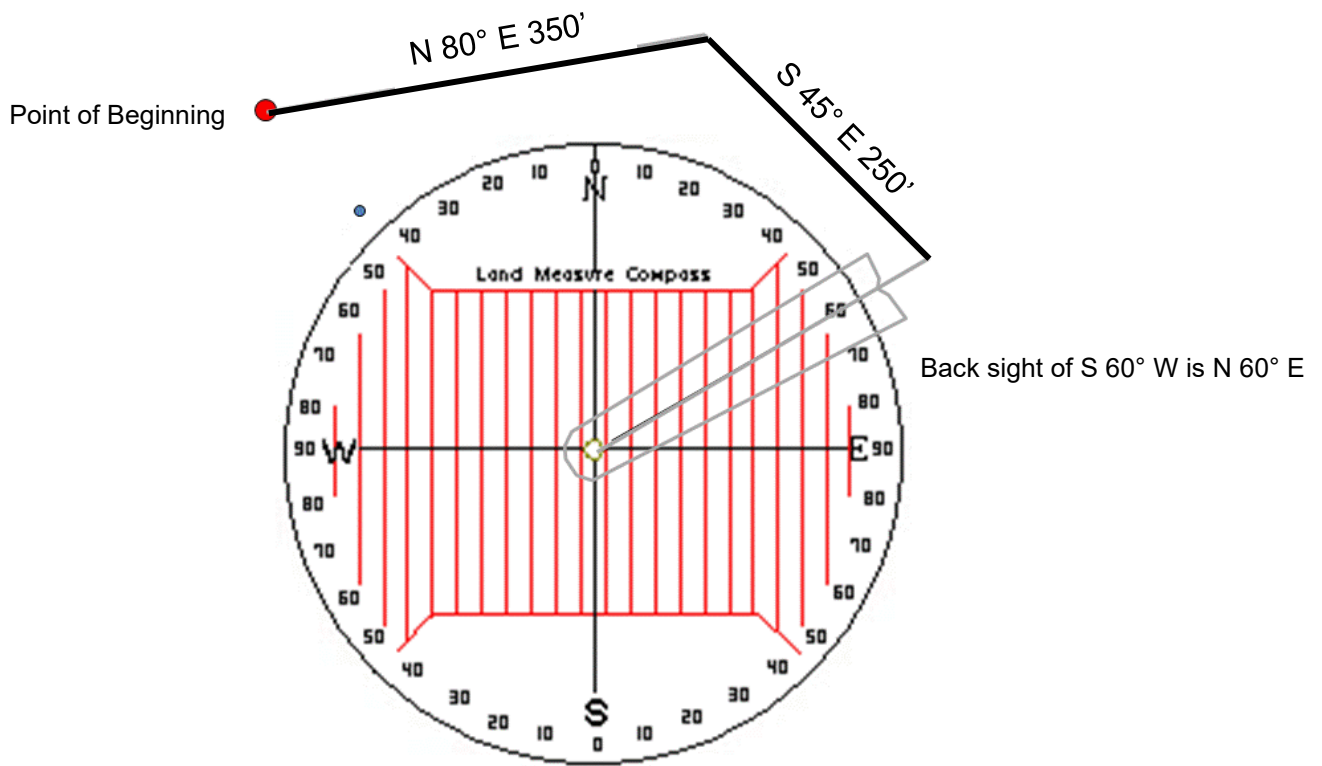

Step 11: Without moving the land measure compass, from Point C, mark a line on the map using the fourth and final bearing (N 45° W).

Step 12: Remove the land measure compass, and using a drafting scale, place the "375" on Point C, and line up the scale with the mark made at the N 45° W bearing. Then draw a line that represents 375'. With a map scale of 1" = 100', that would be a line that is 3.75 inches long back to the POB. (Note: if this final line does not connect with the point of beginning, check the accuracy of each bearing and line length).

Back sight of S 60° W is N 60° E

Beginning at a point, thence N 80° E, 350'; thence S 45° E 250'; thence S 60° W 300'; thence N 45° W, 375' to the point of beginning.

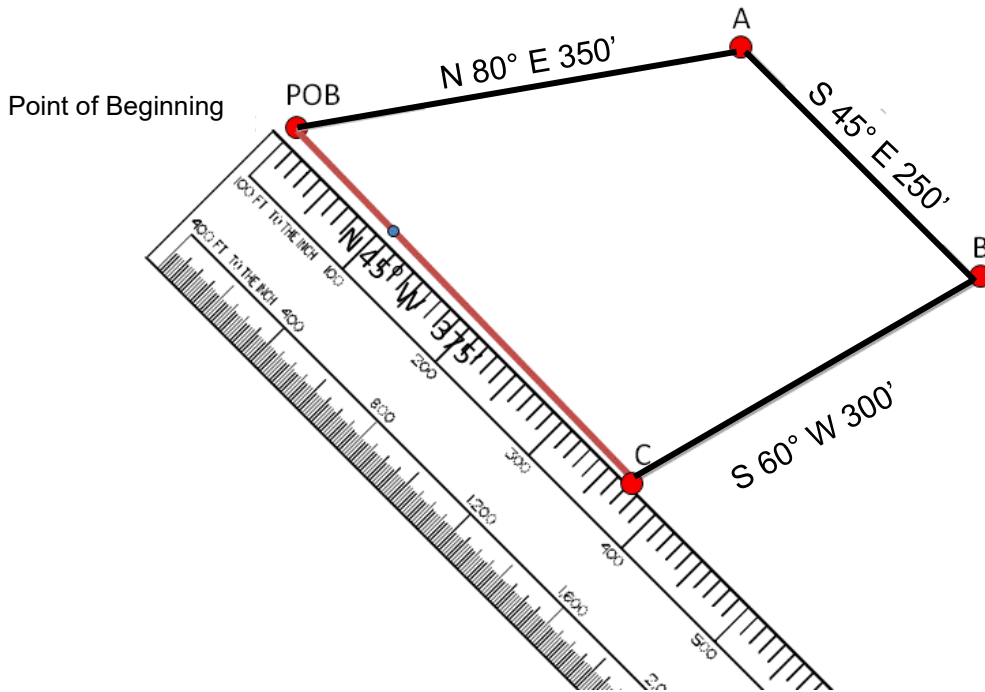

Beginning at a point, thence N 80° E 350'; thence S 45° E 250'; thence S 60° W 300'; thence N 45° W, 375' to the point of beginning.

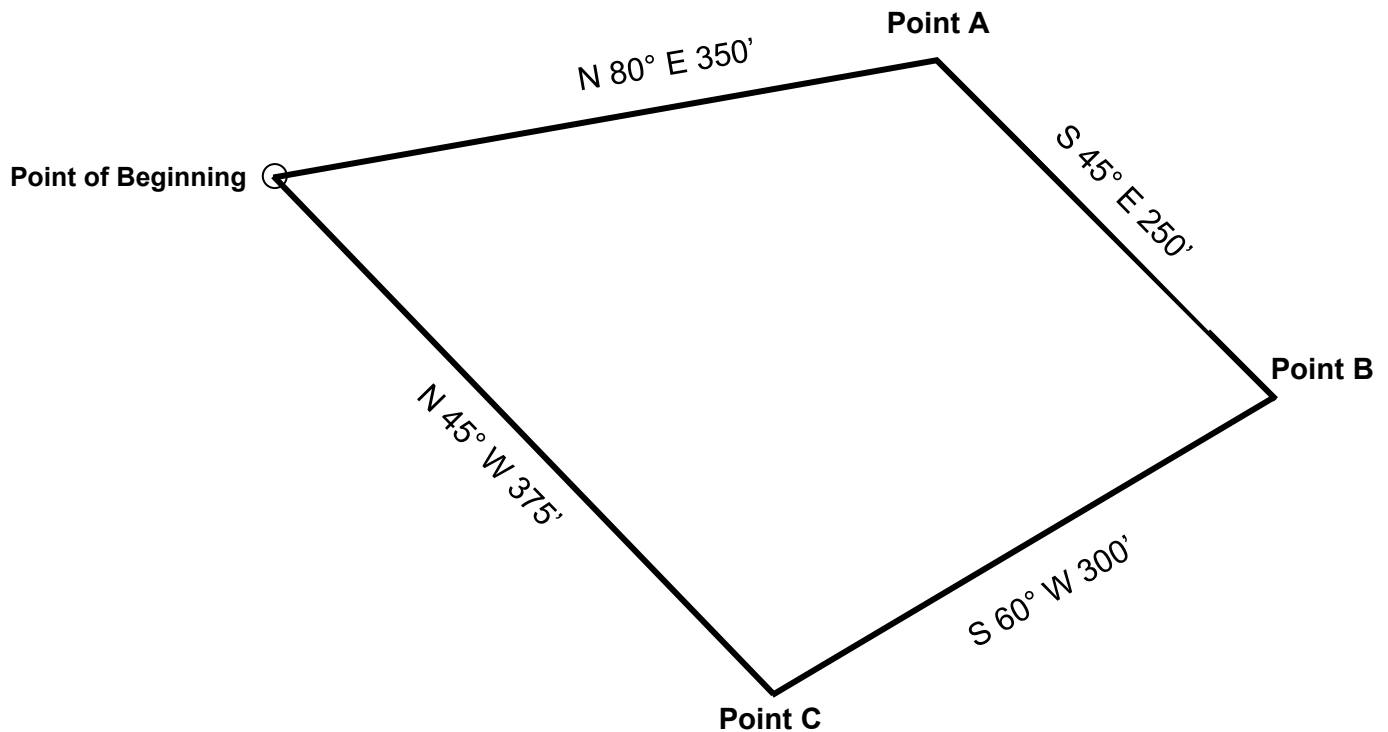

For additional practice, draw a large dot on another sheet of paper at the same spot on the page as your POB on this drawing. Use the legal description above to make a copy. The copy should fit exactly on top of the drawing above. Other drawings will be accomplished on the following pages.

Unit 5, Exercise 5-2 Drawing Legal Descriptions

Remove this page from your binder to make drawing easier!

Using a scale of 1" = 100 feet, draw the following legal descriptions. The dot represents the point of beginning for each description. **Label your drawings!**

1. Beginning at a point, thence N 80°E, 400'; thence S 30°E, 300'; thence S 80°W, 300'; thence N 46°W, 350', to the point of beginning.

Place your compass on the dot below and orient the compass so that North is straight up.

Beginning from the North on the compass, find the mark on the compass that is 80° to the East of North and mark this place on the paper.

Now place your drafting scale on the dot below and line it up with the mark that you just made. Draw a line from the dot along the ruler 4.0" (400 feet ÷ 100 feet = 4.0")

Next, backsight to orient the compass. Place the compass on the end of the line you just drew. Orient the compass so that the line you just drew is at the place on the compass that has a bearing of 80°

Continue with the traverses. You should end up at the point of beginning.



Remove this page from your binder to make drawing easier!

2. Beginning at a point, thence N 82°E, 450'; thence S 10°W, 200'; thence S 82°W, 250'; thence N 43°W, 230' to the point of beginning.

Scale 1:100



Remove this page from your binder to make drawing easier!

3. Beginning at a point, thence S 77°E, 500' to a point; thence S 40°W, 250' to a point; thence N 65°W, 250' to a point; thence N 29°W, 220' to the point of beginning.

Scale 1:100



Remove this page from your binder to make drawing easier!

4. Beginning at a point, thence S 78° E, 425' to a point; thence S 15° E, 100' to a point; thence S 85° W, 550' to a point; thence N 25° E, 260' to the point of beginning.

Scale 1:100



Remove this page from your binder to make drawing easier!

5. Beginning at a point, thence N 23° E, 175' to a point; thence N 68° E, 350' to a point; thence N 88° E, 150' to a point; thence S 32° E, 250' to a point; thence S 53° W, 150' to a point; thence N 67° W, 150' to a point; thence S 80° W, 420' to the point of beginning.

Scale 1:100



Extra Practice for Over-Achievers!

Use the Blank Page following to complete the drawing

6. Using a scale of $1'' = 200'$, please draw the following legal description and calculate the total acreage.

Note that in this legal description “Commencing at” leads you to the point of beginning.

Commencing at the Northwest corner of Section 6, Township 11 South, Range 2 West of the 3rd Principal Meridian, thence East along the Section line 460 feet to the **point of beginning**. Thence continue East 90° , 200 feet to a point; thence S 0° , 45 feet to a point; thence East 90° , 50 feet to a point; thence S 0° , 40 feet to a point; thence W 90° , 110 feet to a point thence S 0° , 815 feet; thence N 38° W, 105 feet to a point; thence W 90° , 40 feet to a point; thence S 0° , 30 feet to a point; thence W 90° , 35 feet to a point; thence S 0° , 50 feet to a point; thence W 90° , 150 feet to a point; thence N 0° , 180 feet to a point; S 40° W, 235 feet to a point; thence W 90° , 45 feet to a point; thence N 0° , 470 feet to a point; thence E 90° , 195 feet to a point; thence N 58° W, 225 feet to a point; thence N 0° , 80 feet to a point; thence E 90° , 195 feet to a point; thence N 0° , 145 feet to a point; thence N 70° E, 160 feet to a point; thence N 0° , 45 feet to the point of beginning

Drawing for Over-Achievers!
Northwest Corner



Unit 5 Summary

Various tools are of assistance when drawing metes and bounds descriptions. Since many descriptions are given in bearings and distances of each traverse listed, it is necessary to have some type of compass to measure the bearings or degree of angles.

A right triangle is helpful to keep parcel drawings square as well as to identify right angles when calculating the area of a right triangle.

A ruler or drafting scale is also a needed instrument to measure the distances.

When drawing out legal descriptions, it is important to understand map scale. To convert property line distances into map scale to represent the line appropriately on the map, divide the legal description measurement by the map scale. If the paper to map scale is 1"-100', then 1 inch on the map equals 100 feet on the ground.

A bearing is the direction of a line measured as the acute angle from a reference meridian.

A traverse is the distance traveled.

POB = Point of Beginning

A properly measured parcel drawn by outlining the boundary should "close", meaning the point of beginning and the end point should meet.

Unit 5 Review

1. Conversion- Draw the following legal description and calculate acreage.

Use your 1:400 scale.

Beginning at the Northwest corner of the Southwest Quarter of Section 12, Township 8 North, Range 3 West of the Third Principal Meridian; thence East 2 Furlongs; thence South 6 rods; thence East 2 chains, 1 rod; thence South 26 degrees East 990 feet, thence West 2 furlongs, 34 rods; thence North 1000 feet to the point of beginning, containing _____ acres, more or less.



2. Please draw and compute the acreage for the Harper parcel. Use the Scale **1" = 100'** and complete your drawing below.

Beginning at the SW corner of the SE $\frac{1}{4}$ of the NE $\frac{1}{4}$ of Section 27, Township 12 South, Range 2 West of the 3rd PM, thence N 275 feet to a white pine tree, thence East 38 feet to a stone, thence S 50 feet to a fence post at the corner of the Brown farm, thence E 200 feet to a maple tree 2 inches in diameter, thence S 28° E 250 feet to a Wahoo, thence W 350 feet to the point of beginning, containing _____ acres, more or less.

The Harper Parcel

●

Unit 6 Assigning a Property Index Number (PIN)

Learning Objectives

After completing the assigned readings, you should be able to

- locate real property using a PIN.
- create a PIN.
- follow a series of property sales.

Terms and Concepts

Description

Section

Parcel

Section Number

Property Index Number (PIN)

Subdivision

Range

Township

Lot and Block

The Property Index Number

A Property Index Number (PIN) is another form of a legal description. This is since, just like a written legal description, a PIN identifies one specific parcel. If a parcel splits, the description of the original and new parcel changes. Therefore, the PIN must also change.

There are principles for assigning PIN numbers. When used consistently throughout the county, finding a parcel based on a PIN is equivalent to using a written legal description. When assigning PINs, these principles apply:

1. A change of ownership without any change in property boundaries does not necessitate a new parcel number. As long as the boundary of the property does not change, like a written legal description, the PIN does not change either.
2. Parcel splits require the original number to be retired. The original owner (**grantor**) would be assigned the next available number, and the new owner (**grantee**) would be assigned the next number after that assignment.
3. Once a parcel number is placed on the assessment roll, it becomes a **legal description**. Consequently, as stated above, when the boundaries of a parcel are changed, the resulting parcel must have a new number assigned to denote the new legal description.
4. Block numbers are assigned according to the lowest numbered block in which a person owns property. (Block numbers will be discussed in the following pages.)
5. A PIN is a 14-character series of numbers that describe the geographic location and use of a specific tax parcel. No two parcels share the same PIN.

Example 07 – 32 – 203 – 021 – 0040

07 = County Township Number
32 = Township Section Number
203 = Block Number
021 = Parcel Number
0040 = Use or Unit Number

County Township Number Derivation

The Congressional Township and Range numbers used in the Rectangular Survey System (T21S, R14W, etc.) are impractical for use in the County PIN due to the fact that it is alpha-numeric and is from 6-8 characters long. Therefore, each county uses a standard County Township number of 2 digits (01-99) as the first two digits of the PIN.

The County Township Number is assigned by overlaying the government survey townships over the county. Beginning in the northwest government survey township of the county, and progressing west to east, then north to south each township is assigned a number.

No matter how small an area of the county in the government survey township, it receives a number. Additionally, the government survey townships do not necessarily correspond to the political townships created with the county.

In this example, there are 15 County Townships. Referring to the example PIN, the County Township is number "07" as highlighted below. The first and second digits in the property index number indicate the county township in which the parcel is located.

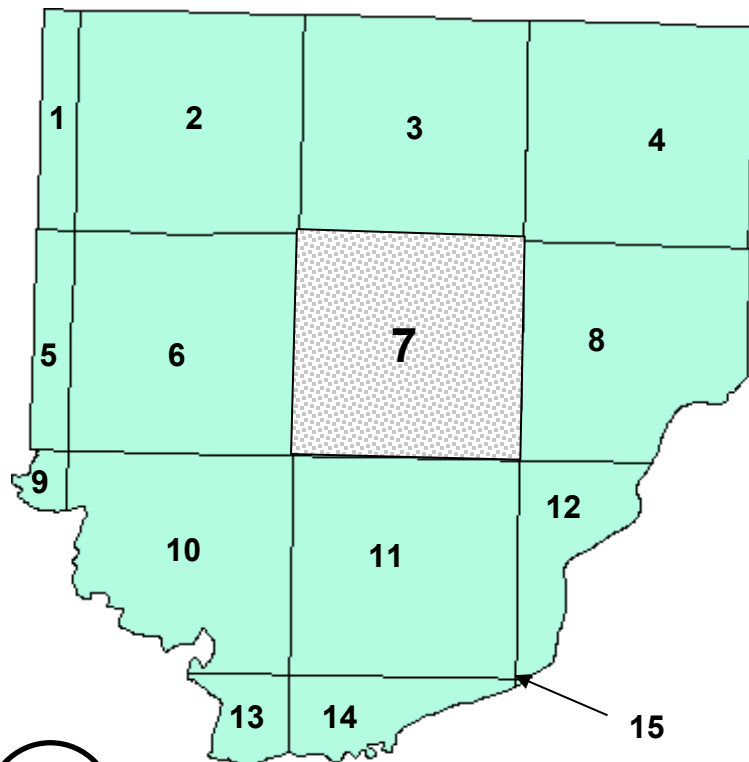

County Township

07				
----	--	--	--	--

Section Number Derivation

6	5	4	3	2	1
7	8	9	10	11	12
18	17	16	15	14	13
19	20	21	22	23	24
30	29	28	27	26	25
31	32	33	34	35	36

Section Number

07

32

--	--	--

The numbering of sections begins in the northeast corner of the township, and progresses west then east, back and forth in a serpentine manner.

Referring back to the example PIN on **page 132**, Section “32” is indicated. The third and fourth digits in the property index number indicate the section in which the parcel is located.

Block Number Derivation

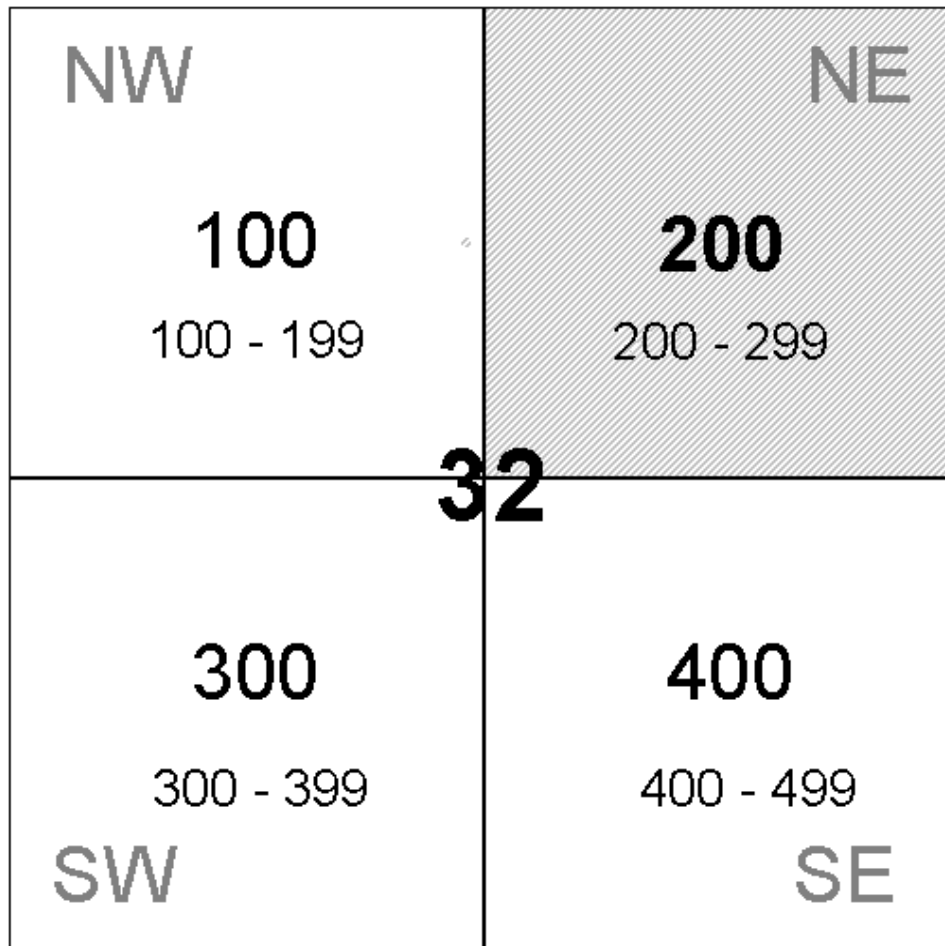

Block Number

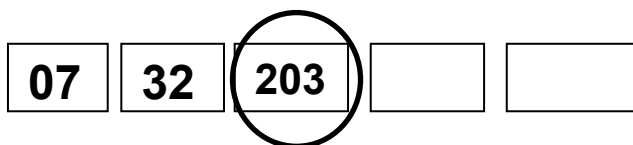

The Block Number refers to the **quarter section within the section**. The numbering of the blocks begins in the northwest quarter of the section, and progresses west to east, north to south. As illustrated above, property in the northwest quarter of the section would receive a block number between 100 and 199; the northeast quarter 200 to 299; the southwest quarter 300 to 399 and the southeast quarter 400 to 499. The specific number is dependent upon any subdivisions with the quarter section. The subdivision numbers are typically assigned in order of creation. However, this varies within each county.

Referring back to the example PIN, Block Number “203” is indicated, meaning the northeast quarter. The 5th, 6th and 7th digits of the property index number indicate the block (in the quarter section) in which the parcel is located.

Parcel Number Derivation

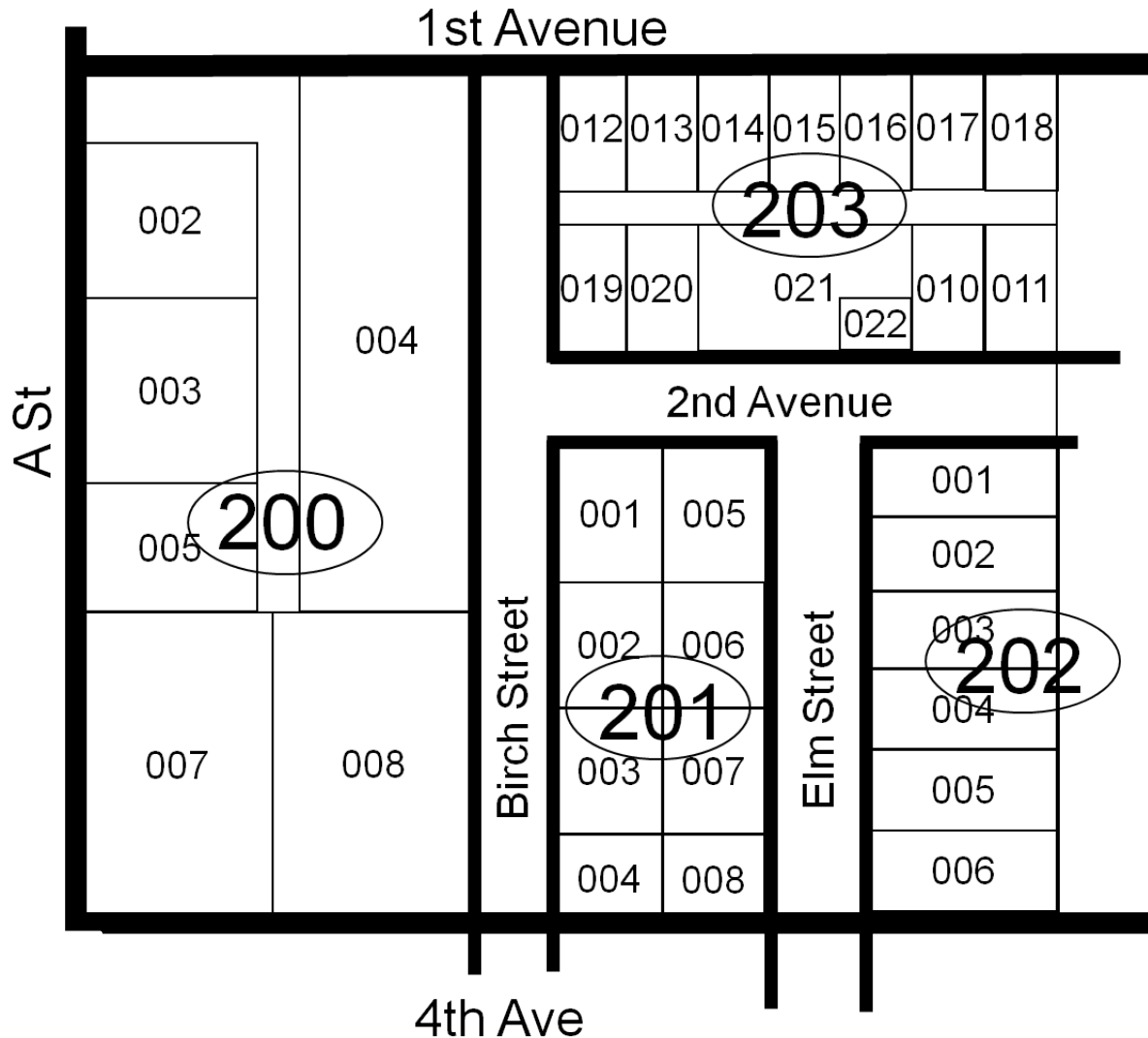

Parcel Number 07 32 203 021

The Parcel Number is unique to the property within a Block. Typically, Parcel Numbers are assigned in the order of creation.

Referring back to the example PIN on **page 132**, Parcel Number “021” is indicated. The 8th, 9th and 10th digits of the property index number indicate the legal description within the quarter section in which the parcel is located.

Unit Number Derivation

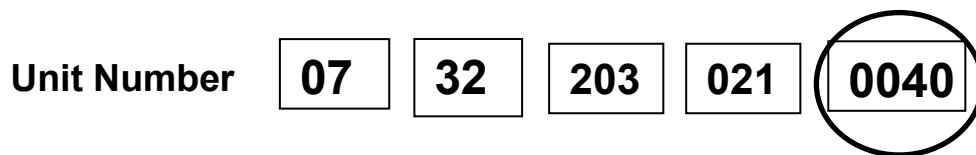
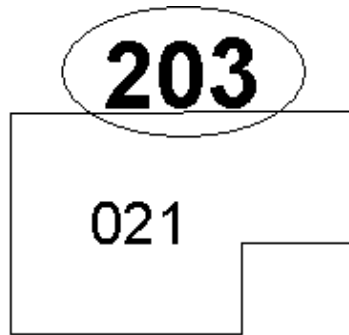

The Unit or Use Number refers to the taxable use of the property, or in the case of condominiums, the unit number.

Referring to the example PIN above, the Use Number "0040" is indicated. The "0040" refers to a residential parcel, with a dwelling. The 11th, 12th, 13th and 14th digits of the property index number indicate the use of the property.

Common Use/Unit numbers:

- 0010 Rural property improved with buildings. Not assessed under the Farm Bill.
- 0011 Rural property improved with buildings. Assessed under the Farm Bill.
- 0020 Rural property not improved with buildings. Not assessed under the Farm Bill
- 0021 Rural property not improved with buildings. Assessed under the Farm Bill
- 0030 Residential vacant land
- 0040 Residential with dwelling
- 0050 Commercial residence – 6 units or more
- 0060 Commercial business
- 0070 Commercial office
- 0080 Industrial
- 0090 Miscellaneous

The PIN number has 14 digits. The first 10 digits refer to the geographical location and the last 4 digits refer to the use of the property.

Rules for PIN Progression Summarized:

- A change of ownership without any change in property boundaries does not necessitate a new PIN.
- Parcel splits require the original number to be retired. The original owner (**grantor**) would be assigned the next available number, and the new owner (**grantee**) would be assigned the next number after that assignment.
- The County Township Number and Section number will not change based on ownership change of a parcel.
- The Block number is assigned based on the first block of the section in which the owner owns property.
- The Parcel number is unique within a block. Parcels can be created by splits and additional property development and their numbers can also be retired.
- The last 4 digits of the PIN can indicate Use and or Unit number. If a parcel's use changes, like from farmland to residential, the PIN should change as well.

Example A: Homeowner Smith sells his house and land to Homeowner Jones. Smith's PIN is 21-32-402-0025-0040. What is Jones' new PIN?

Answer: The PIN is the same-no property boundaries have changed.

Example B: Farmer Brown sells off 5 acres of an entire section of farmland he owns to Businessman Boyd, so Boyd can build his new home. Brown's original PIN is 02-15-100-0001-0011. What are the new PIN's?

Answer: Farmer Brown's original PIN will be retired, and he will get the next available PIN. The only number position that will change will be the parcel number, 0001. Businessman Boyd's new number would be the next available number after that. Depending on where the new parcel is located in the section, the numbers that could change would be the block number (1st block in which the owner owns property; the parcel number (next available); and use number (from farmland 0011 to residential 0040 once the home is built).

Example C: Developer Dawes builds a duplex. The PIN is 03-31-300-0007-0040. He sells one side and lives in the other. What are the new PINS?

Answer: The original PIN is retired, Dawes gets the next available PIN in which the parcel number and use code (if unit number is used) change. The new buyer of the other side of the duplex gets the next available PIN after that.

Unit 6 Exercise 6-1

The goal of this exercise is to understand how to identify the correct PIN for parcels that are created when portions of the original parcel are sold. For this exercise, the original parcel is the entire section (640 acres). The County Township Number shall be '01'.

Using the map (grid) of Section 26 provided next to each transaction, identify the PINs for the following real estate transactions. Section 26 is the Rectangular Land Survey section number while the "01" in the PIN refers to the first township in the NW corner of the county. As the transactions are completed, it is recommended that the areas of Section 26 are shaded in to assist with tracking the property associated with the original PIN. **The use for the property will be "0021" designating "farmland."**

Transaction "A":

Section 26

Grantor: Thomas and Judy Bates
Grantee: Richard and Rebecca Heart
Date: November 25, 1984
Legal: Section 26 Twp. 4S, Range 3 West, 3rd PM
(640 acres)

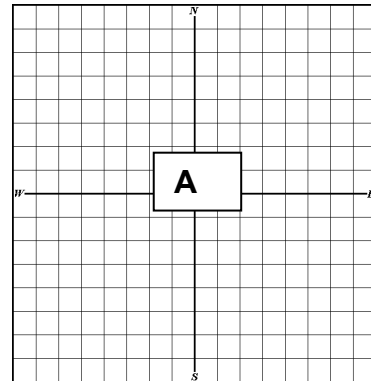

Original PIN 01-26-100-001-0021

(A) 01-26-100-001-0021 (Heart Tract)

Since the Grantor owns all 640 acres of Section 26, the block number is 100, because remember block number is determined by the first block of the section in which you own property. Since he has all 640 acres, the parcel number will also be the first, or 001. The use is 0021 as given in the description. **Conveying the parcel will not change the PIN**

Transaction "B":

Section 26

Grantor: Richard and Rebecca Heart
Grantee: Thomas Johnson
Date: April 17, 1989
Legal: The SW ¼ of Section 26, T 4S, R 3W, 3rd PM
(160 acres)

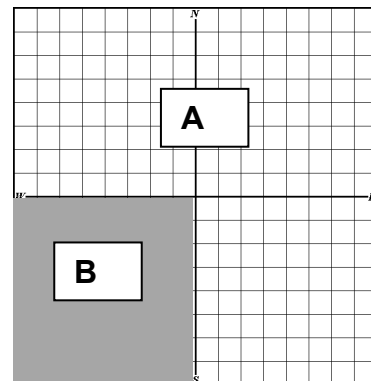

01-26-100-002-0021 (Heart Tract)

(B) 01-26-300-001-0021 (Johnson Tract)

Both parcel numbers will change here because now Heart does not own all of the property in Section 26. Heart gets the next available parcel number in the sequence and the original PIN is retired. The next number would be **01-26-100-002-0021**.

So now Johnson owns property in Section 26 of the same township (01). And the first block in which he owns property is in the 300 block. He owns the one and only parcel in the 300 block, so his block number is 300 and his parcel number is 001. The use code remains 0021 for farmland. The Johnson tract is now **01-26-300-001-0021**

Transaction "C":

Section 26

Grantor: Richard and Rebecca Heart
 Grantee: Christopher Freeman
 Date: February 7, 1990
 Legal The NE 1/4 of the NE 1/4 of Section 26,
 T 4S. R 3W, 3rd PM
(40 acres)

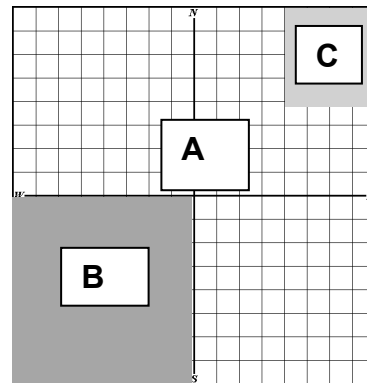

01-26-100 003-0021 (Heart Tract)

(C) 01-26-200-001-0021 (Freeman Tract)

The Grantor, Heart, is still conveying property. The NE 1/4 of the NE 1/4 now goes to Freeman. The Johnson property (B) has no boundary line changes, so its PIN remains the same. The Heart track does have a boundary change, which means its PIN must change, too. Heart gets the next available parcel number in the sequence and the original PIN is retired. The next available PIN is **01-26-100 003-0021**.

The newcomer, Freeman, has his first property in the Section in the 200 block, so he will get a new PIN of **01-26-200-001-0021**

Transaction "D":

Section 26

Grantor: Richard and Rebecca Heart
 Grantee: John and Mary Carter
 Date: March 4, 1990
 Legal Description: The NW 1/4 of the NW 1/4 of
 Section 26, Twp. 4S, Range 3 West, 3rd PM
(40 acres)

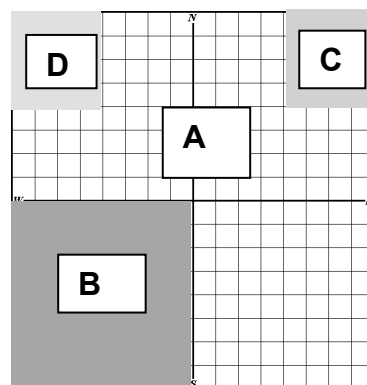

01-26-100-004-0021 (Heart Tract)

(D) 01-26-100-005-0021 (Carter Tract)

For this conveyance, only the new buyer, Carter, and the Hearts will have changes to their boundaries. Heart will again have to retire his PIN and get the next in line. Their first property owned is still in the 100 block, so the block number would remain the same, but the parcel number would change. That would be **01-26-100-004-0021**. Now Carter also owns property in the 100 block (or Northwest Quarter). So, he gets the next available number after Heart's new number. **01-26-100-005-0021**

Solve for the following conveyances. Indicate the new parcel on the map.

Transaction "E":

Section 26

Grantor: Richard and Rebecca Heart
Grantee: Thomas Jones
Date: April 1, 1990
Legal Description: The SW 1/4 of the NW 1/4 of Section 26, Twp. 4S Range 3 West, 3rd PM
(40 Acres)

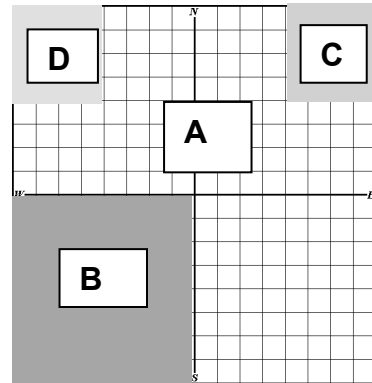

01-_____ (Heart Tract)

(E) 01-_____ (Jones Tract)

Transaction "F":

Section 26

Grantor: Richard and Rebecca Heart
Grantee: Mike and Christine Weber
Date: June 1, 1991
Legal Description: The NE 1/4 of the NW 1/4 and the SE 1/4 of the NW 1/4 of Section 26, T 4S., R 3W, 3rd PM
(80 acres)

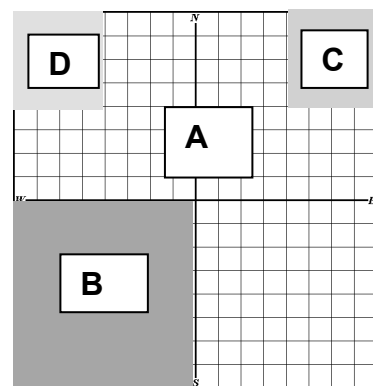

01-_____ (Heart Tract)

(F) 01-_____ (Weber Tract)

Unit 6 Exercise 6-2

On the section map that follows on Page 145, identify the PINs for the following real estate transactions and calculate the acreage for each. For the purposes of this exercise, the township number has been provided.

Real Estate Transaction "A"

Deed Record 104, page 570
Grantor: Larry L. Davis
Grantee: Patrick D. and Rebecca J. Joseph
Date: May 9, 1988

Legal Description: The Northeast Quarter; and the Northwest Quarter; and the Southeast Quarter; and the Southwest Quarter being all of Section 36, Township 8 South, Range 1 East of the Third Principal Meridian.

Containing _____ acres, more or less. PIN: 08-_____ (Joseph tract)

Real Estate Transaction "B"

Deed Record 108, page 669
Grantor: Patrick D. and Rebecca J. Joseph
Grantee: James Harris
Date: February 14, 1989

Legal Description: The South 1320' of the entire NW 1/4, Section 36, Township 8 South, Range 1 East of the Third Principal Meridian.

Containing _____ acres, more or less

PIN: 08-_____ (Joseph tract)

PIN: 08-_____ (Harris tract)

Real Estate Transaction "C"

Deed Record 110, page 238
Grantor: Patrick D. and Rebecca J. Joseph
Grantee: Thomas Davis
Date: May 12, 1989

Legal Description: Beginning at the Southwest corner of Section 36, Township 8 South, Range 1 East of the Third Principal Meridian, thence North 2,640' to a point, thence East 2,640' to a point, thence South 2,640' to a point, thence West 2,640' to the point of beginning.

Containing _____ acres, more or less.

PIN: 08-_____ (Joseph tract)

PIN: 08-_____ (Davis tract)

Real Estate Transaction "D"

Book 150, page 222

Grantor: Patrick D. and Rebecca J. Joseph

Grantee: Richard Charles

Date: May 25, 1989

Legal Description: Beginning at the Northwest corner of Section 36, Township 8 South, Range 1 East of the Third Principal Meridian, thence South 1320' to a point; thence East 1320' to a point; thence North 1,320' to a point; thence West 1320' to the point of beginning. **Also**, the NE 1/4 of the NW 1/4 of Section 36.

Containing _____ acres, more or less.

PIN: 08-_____ (Joseph tract)

PIN: 08-_____ (Charles tract)

Real Estate Transaction "E"

Deed Record 310, page 339

Grantor: Patrick D. and Rebecca J. Joseph

Grantee: Gary Hardy

Date: November 25, 1989

Legal Description: South 1/2 of the West 1/2 of the SW 1/4 of the SE ¼ of Section 36, Township 8 South, Range 1 East of the Third Principal Meridian

Containing _____ acres, more or less.

PIN: 08-_____ (Joseph tract)

PIN: 08-_____ (Hardy tract)

How many acres remain in the Joseph parcel? _____ acres.

Unit 6, Exercise 6-2 Drawing (draw parcels all on one grid)

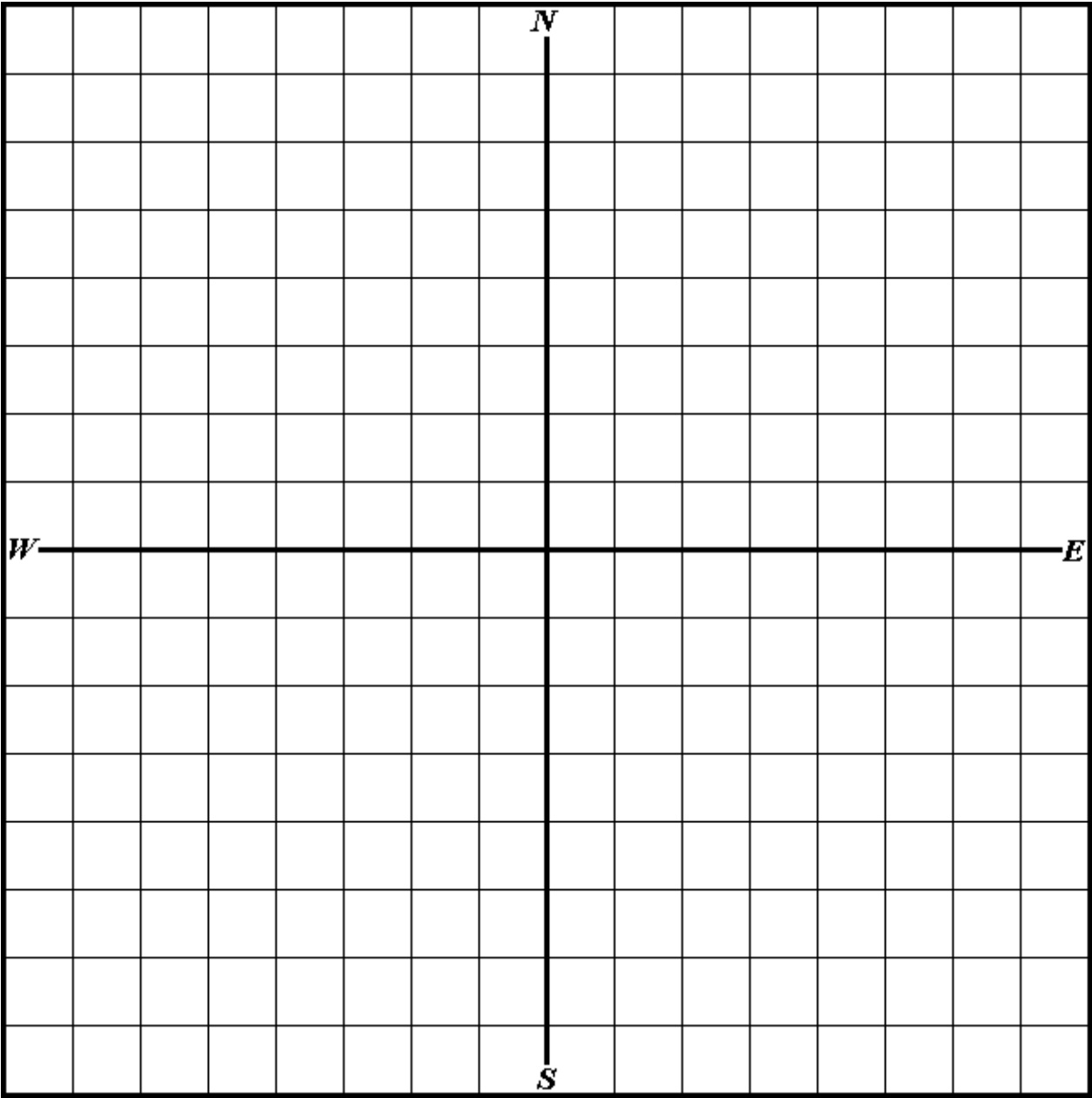

Unit 6 Summary

A PIN is a 14-character series of numbers that describe the geographic location and use of a specific tax parcel. No two parcels share the same PIN.

There are principles for assigning PIN numbers. When used consistently throughout the county, finding a parcel based on a PIN is equivalent to using a written legal description. When assigning PINs, these principles apply:

- A change of ownership without any change in property boundaries does not necessitate a new PIN nor a new legal description.
- A PIN can be a legal description of property.
- Parcel splits require the original number to be retired. The original owner (**grantor**) would be assigned the next available number, and the new owner (**grantee**) would be assigned the next number after that assignment.
- Once a parcel number is placed on the assessment roll, it becomes a **legal description**. Consequently, as stated above, when the boundaries of a parcel are changed, the resulting parcel must have a new number assigned to denote the new legal description.
- Block numbers are assigned according to the lowest numbered block in which a person owns property.
- The Parcel number is unique within a block. Parcels can be created by splits and additional property development and their numbers can also be retired.
- The last 4 digits of the PIN can indicate Use and or Unit number. If a parcel's use changes, like from farmland to residential, the PIN should change as well.

Unit 6 Review Questions

Draw the property described on the following sheet and record the PINS for each property and calculate the acreage. **Scale 1:660**

Mikey Moose owns the property described as all of Section 16.
The PIN is 01-16-100-001-0020

Mr. Moose decides to convey the following to Duffy Duck:

(A) Moose to Duck

Legal....**SE $\frac{1}{4}$ of the NE $\frac{1}{4}$ of the SE $\frac{1}{4}$ of the NW $\frac{1}{4}$**
_____Acres, more or less.

Moose PIN _____

Duck PIN _____

Now Mr. Moose decides to convey some property to Froghorn Leaphorn.

(B) Moose to Leaphorn

Legal...**SE $\frac{1}{4}$ of the NE $\frac{1}{4}$ of the NE $\frac{1}{4}$ of the NE $\frac{1}{4}$**
_____Acres, more or less

Moose PIN _____

Leaphorn PIN _____

Once again, Mikey Moose conveys some property to Why Lee Coyote.

(C) Legal.... **S $\frac{1}{2}$ of the NE $\frac{1}{4}$ and the NW $\frac{1}{4}$ of the NE $\frac{1}{4}$ of the SE $\frac{1}{4}$.**

_____Acres, more or less

Moose PIN _____

Coyote PIN _____

Finally, Mr. Moose makes a new friend, Tweety Byrd, and decides to convey to her:

(D) Legal.... **From the point of the SW corner of Section 16, traverse East 1155 feet to the POB. Thence North 330', thence E 165 feet, thence South 330 feet, thence West 165 feet.**

_____Acres, more or less.

Moose PIN _____

Byrd PIN _____

Unit 6, Review Questions The Property of Mr. Mikey Moose, Section 16
Scale 1:660

Section 16 PIN 01-16-100-001-0020

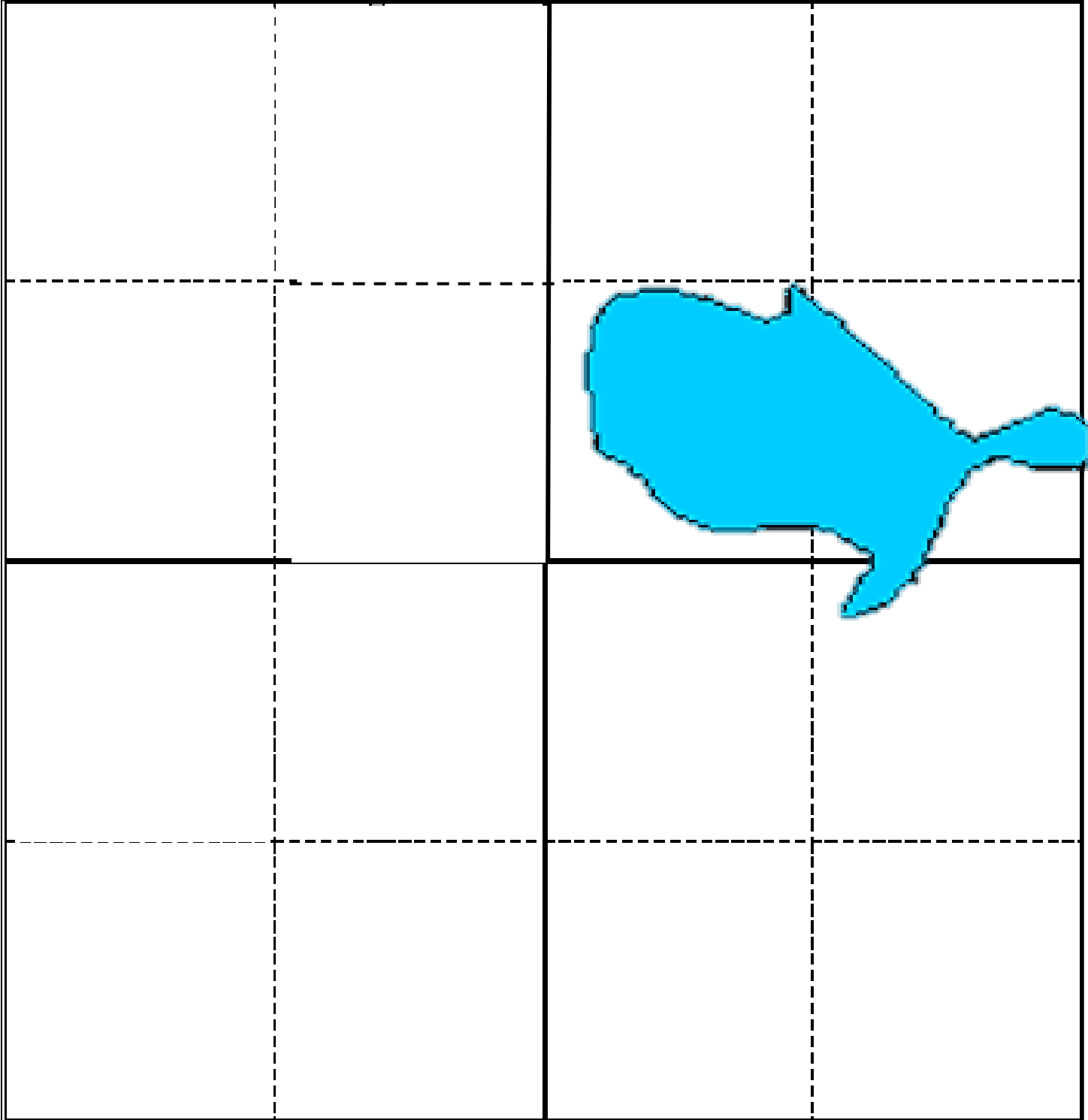

Unit 7 GIS and Mapping

This unit covers the use of GIS in mapping and assessing property.

The purpose of this unit is to provide an understanding of how computers and a GIS are used in modern mapping.

Learning Objectives

After completing the assigned readings, you should be able to

- explain the benefits of using computerized data.
- define GIS and GPS.
- understand the uses of a GIS.

Terms and Concepts

Geographic Information System (GIS)

Global Positioning System (GPS)

Vector Data

Raster Data

Attributes

GPS Technology Makes GIS Maps a Reality

Maps historically were drawn, photographed, and measured “by hand”. Satellite technology that we use every day on our phones, in our cars, and on our jobs is provided by GPS technology. But what really is **GPS**?

GPS is the Global Positioning System owned by the U.S. government. It is a utility comprised of a constellation of satellites flown into space and controlled by the U.S. Air Force. As of the writing of this manual, there are currently 31 satellites in the GPS constellation which transmit radio signals to users. The satellites circle the Earth two times per day. Data that is collected by the satellites can be used in local GIS mapping systems.

GPS supports the accurate mapping and modeling of the physical world — from mountains and rivers to streets and buildings to utility lines and other resources. Features measured with GPS can be displayed on maps and in geographic information systems (GIS).

Computerized Mapping

Geographic Information System (GIS)

A Geographic Information System is a system designed to capture, store, manipulate, analyze, manage and present spatial or geographic data.

The property tax assessor can use GIS as another tool to provide fair and equitable property tax assessments.

GIS allows the assessor to view, understand and visualize data in many ways that can reveal relationships, patterns and trends in the form of maps, reports and charts. Its main strength lies in allowing the user to view data to select, sort, list, group, report and print data by a wide variety of criteria.

GIS was developed for spatial analysis needs such as planning, natural resources, and land records management. It offers the ability to integrate spatial data (map layers) and attribute data (information from a database) among different layers, which makes it ideal for multi-purpose users.

Each layer in the GIS can be compared to a single map overlay. For example, planimetric features such as bodies of water, soil types, geologic structure, land use, zoning, political boundaries, utilities, sewers, topography, property lines, and others can be overlaid.

Especially noteworthy are the GIS systems that can provide past and present polygon changes (outline of a home or property) to help detect new improvements or previously undetected improvements.

The photo on the left is 1 year old. The GIS flagged this photo on the right as a property that may have changed. The new polygon overlay indicates a large addition to the structure.

Previous

Current

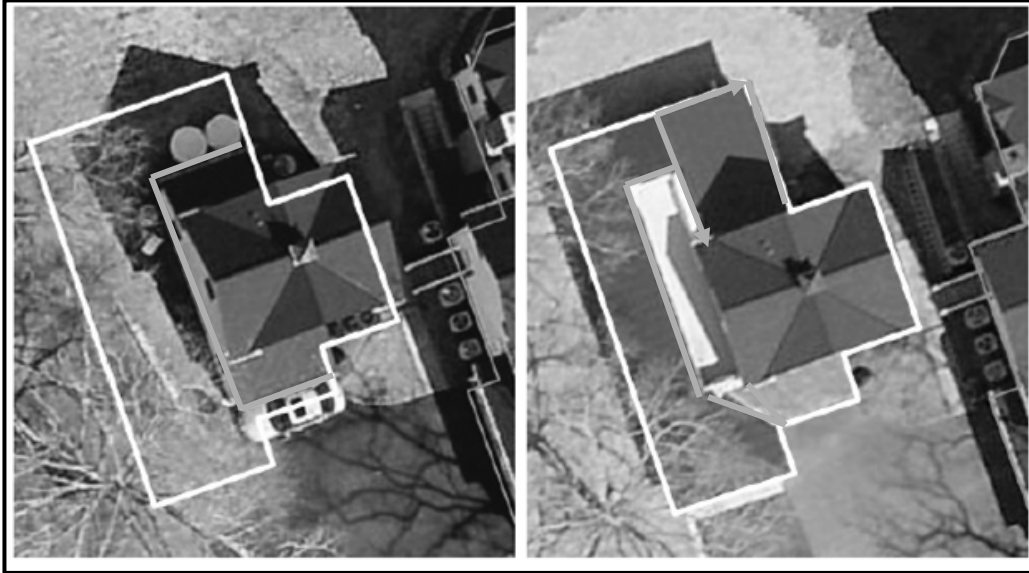

Previous

Current



Looks like a new pool and patio as well as a second story addition-note the changes to the roofline...

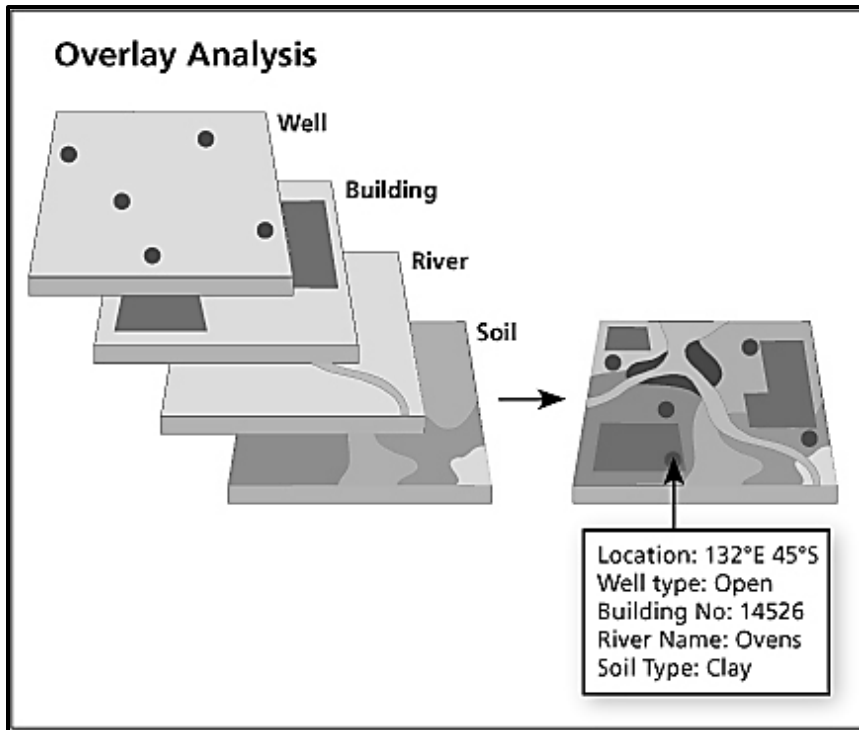

Data and Mapping Systems

GIS data represent real objects (such as roads, houses, trees, elevation, etc.) with digital data determining the mix. Real objects can be divided into two forms—discrete objects, (like a building); and continuous field (like elevations) and can be stored as raster images and vector images. **GIS vector data** appear on the map as a specific type of shape which can either be a point, line or polygon (area). Each map layer is a collection of these points, lines or polygons.

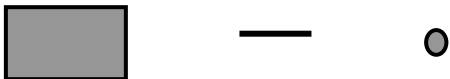

Each feature (a single point, line or polygon) in a GIS has a geographic or “shape” component and a tabular “attribute” component. The **geographic component** is the visual part that appears on the map and is tied to a location on the earth. The **attribute component** contains a record of information such as name, parcel identification number, block number and parcel address.

The tabular component supports relationships with other tables by using traditional database linked key fields. However, a GIS “geodatabase” supports spatial, or location, relationships as well. It is this geographic location aspect that makes GIS data appear in the correct location on the map in relation to other data.

The visualization of the data helps to find answers to important questions relating to “Place”.

- Where are these addresses or parcel numbers?
- What is near the place of interest?
- How large is the parcel?
- What else could be influencing this site?

Other GIS Technology

Assessors have even newer and less expensive tools at their fingertips with the advent of the smart phone. Besides regular software programs that can be installed on an office PC, phone applications, or “apps”, are available for assessors, realtors, property buyers and surveyors to use on their phones. This technology can locate and draw legal descriptions.

For instance, there are apps for both iPhones and android phones that can be downloaded for free or as little as five dollars that can translate the coordinates of a metes and bounds description to a closed drawing. If the user does not know actual GIS coordinates, some of these apps allow the user to bring in the coordinates to their phone while visiting the subject property.

These apps can be used in finding errors and discrepancies in deeds and legal descriptions. Sometimes, linear measurements are incorrect, directions are wrong, and size calculation errors often occur. As use of these products increases and errors are corrected, the data quality overall will increase, hopefully making the assessors’ jobs easier.

GIS Benefits for Assessors, Township and County Offices

Digital technology is one of the greatest enhancements for mapping in recent history. Some advantages of using computers in a modern mapping program are speed, precision, flexibility, productivity, display capabilities, storage and retrieval efficiencies, and improved correction of errors and omissions. Another notable advantage is ease of providing updates, and elimination of shrinkage or quality deterioration of base material (transparency and paper) over time.

Summary of benefits of computerized data vs. hard copy data

- easy to share
- takes less space
- preserves information
- inventories information
- analyzes information
- organizes information
- displays information

If an office does not already use a GIS mapping system, use of these systems can provide many benefits by dramatically reducing time and expense of field assessments. It can also increase revenue by allowing the assessor to discover previously undetected improvements. Other benefits include:

- determining changes based on polygonal shape overlays.
- identifying changes more quickly.
- saving on staffing, vehicle and fuel costs.
- providing access to gated, uninhabited, and other hard-to-reach structures.
- finding new improvement quickly in areas where no permits are used or not applied for (often farms).
- providing a solution to restrictions against traveling between farms due to risk of spreading bacteria or disease.
- improving map maintenance to most current version.
- overlaying layers of data.

Often, costs and use can be shared with other entities, like police, fire, and the public.

Additionally, use of a GIS mapping system can help improve communications in the assessment office by

- using images during the appeal process.
- easing complaint resolution at protest time.
- reducing confrontations from property owners when images can be discussed face-to-face.
- reducing time for complaint resolution by eliminating many field inspections.

Unit 7 Summary

GIS vector data appear as basic points, lines, and polygons (enclosed areas) that make up the features of a map.

GIS refers to geographic information system.

GPS refers to the Global Positioning System owned by the U.S. government.

There are many benefits to providing assessors with tools to help them make fair and equitable assessments.

Unit 7 Review Questions

1. Define GIS

2. What are three benefits of GIS for assessors?

3. Define GIS Vector data.

Examination Information and Prep

- The exam consists of 50 multiple choice questions.
- Each question is worth an equal number of points when the exam is graded.
- There is only one best answer for each question on the examination.
- Two hours are allotted for completion of the exam.
- The exam is closed book. All class materials, papers, computers, and cellular devices must be removed from the table before taking the exam.
- Cellular phones may not be used as calculators.

Test-Taking Strategies

- Read each question thoroughly and choose the one best answer provided.
- Review the answer sheet for any skipped answers or multiple answers for the same question.
- Tips for taking a multiple-choice exam:
 - Some test-takers prefer to answer questions that they are confident in the answers first and choose to skip over harder questions or questions that involve math calculations. If this is done, be sure to complete the correct answer on the answer sheet for the questions being answered. The answer sheets are graded by hand, so question numbers may be circled so that they can be easily identified during the second pass through the exam.
 - Be mindful of the time allotted. If a question is taking a lot of time to answer, move past it and come back to it later.
 - Guessing an answer is better than leaving it blank if time becomes an issue.

Course Answer Key

Unit 1 Review Answers

1. What is an aerial mosaic map? **An assembly of aerial photographs to form a continuous photographic representation of a portion of the Earth's surface.**

2. What is a topographic map? **A map which represents the horizontal and vertical position of the land features.**

3. What is a cadastral map? **A map that shows the size, shape, and extent of each land parcel for purposes of describing and recording ownership.**

4. What is the recommended scale for an urban aerial-based tax map?

1" = 100'

5. What is the recommended scale for a rural aerial-based tax map?

1" = 400'

6. What are the basic functions of maps?

1. **Location**

2. **Identification**

3. **Inventory**

7. A Soil Survey Map has 3 sets of alphanumeric characters which indicate what features of the soil (in order):

Soil Type

Slope

Erosion

Unit 2, Exercise 2-1 Answers

<u>Parcel shape</u>	<u>Measurements</u>	<u>Square Footage</u>	<u>Acreage</u>
1. Square	1,528 ft. x 1,528 ft.	<u>2,334,784</u>	<u>53.60</u>
2. Square	680 ft. each side	<u>462,400</u>	<u>10.62</u>
3. Rectangle	1,250 ft. x 1,000 ft.	<u>1,250,000</u>	<u>28.70</u>
4. Rectangle	125 ft. x 75 ft.	<u>9,375</u>	<u>.22</u>
5. Square	65 ch. x 65 ch. 1 ch. = 66 ft. 4,290 ft. x 4,290 ft.	<u>18,404,100</u>	<u>422.50</u>
6. Rectangle	30 ch. x 48 ch. 1 ch. = 66 ft. 1,980 ft. x 3,168 ft.	<u>6,272,640</u>	<u>144.00</u>
7. Triangle	475 ft. x 986 ft. 468,350 sq. ft. / 2	<u>234,175</u>	<u>5.38</u>
8. Triangle	680 ft. x 360 ft. 680 ft. x 360 ft. = 244,800 sq. ft. / 2	<u>122,400</u>	<u>2.81</u>
9. Triangle	22 ch. x 48 ch. 1,452 ft. x 3,168 ft. = 4,599,936 sq. ft. / 2	<u>2,299,968</u>	<u>52.80</u>
10. Triangle	38 ch. x 46 ch. 2,508 ft. x 3,036 ft. = 7,614,288 sq. ft. / 2	<u>3,807,144</u>	<u>87.40</u>
11. Square	5 rds. x 5 rds. 1 rd. = 16.5 ft. 82.5 ft. x 82.5 ft.	<u>6,806</u>	<u>.16</u>
12. Rectangle	5 rds. x 7 rds. 1 rd. = 16.5 ft. 82.5 ft. x 115.5 ft.	<u>9,529</u>	<u>.22</u>
13. Rectangle	200 lks. x 300 lks. 1 lk. = .66 ft. 132 ft. x 198 ft.	<u>26,136</u>	<u>.60</u>
14. Square	(8 chains, 3 rods, 16 links)	<u>345,815</u>	<u>7.94</u>

Unit 2 Review Answers (round SF and carry Acreage to 2 decimal pts)

<u>Parcel shape</u>	<u>Measurements</u>	<u>Square Footage</u>	<u>Acreage</u>
1. Square	1,742 ft. x 1,742 ft.	<u>3,034,564</u>	<u>69.66</u>
2. Rectangle	165 ft. x 95 ft.	<u>15,675</u>	<u>.36</u>
3. Square	82 ch. x 82 ch. (5,412' x 5,412')	<u>29,289,744</u>	<u>672.40</u>
4. Triangle	720 ft. x 490 ft.	<u>176,400</u>	<u>4.05</u>
5. Triangle	27 ch. x 36 ch.	<u>2,117,016</u>	<u>48.60</u>
6. Rectangle	9 rds. x 6 rds.	<u>14,702</u>	<u>.34</u>
7. Rectangle	500 lks. x 38 rds.	<u>206,910</u>	<u>4.75</u>
8. Square (6 chains, 2 rods, 23 links)		<u>197,296</u>	<u>4.53</u>

$$396 + 33 + 15.18 = 444.18 \times 444.18 = 197,296$$

9. Calculate the square footage and the acreage for the following:
Note that the figure is the same on the right side as on the left side.

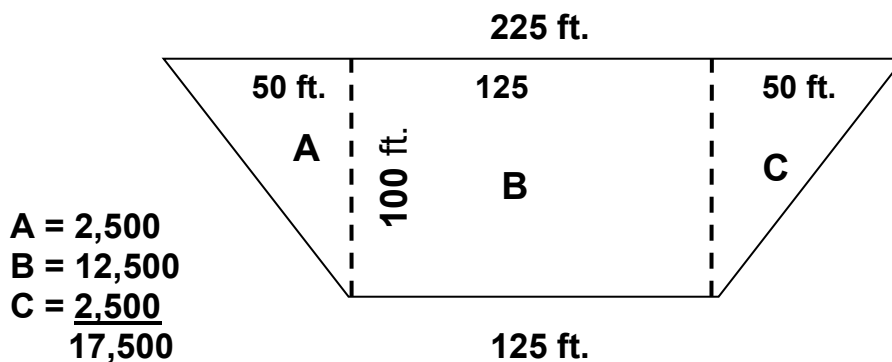

$$\begin{aligned} A &= 2,500 \\ B &= 12,500 \\ C &= 2,500 \\ \hline &17,500 \end{aligned}$$

Square footage 17,500 Acreage .40

10. Calculate the square footage and acreage for the following parcel.

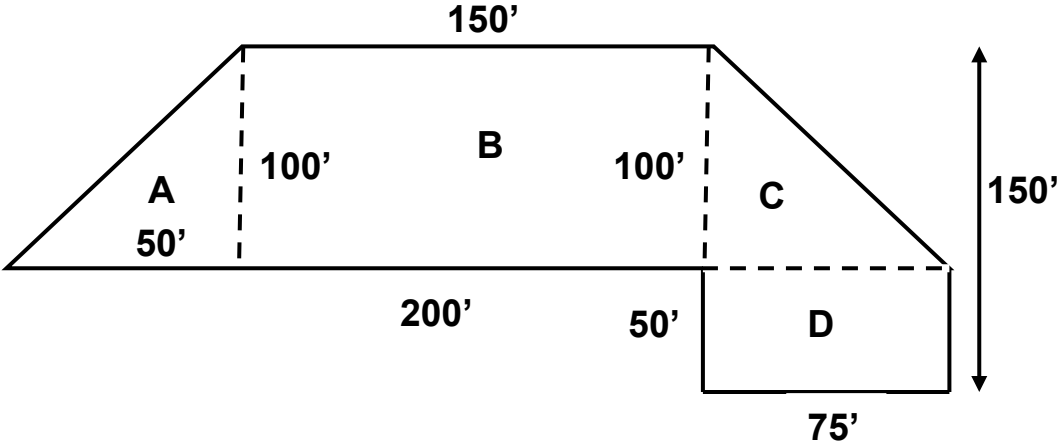

$$\begin{aligned}
 A &= \frac{50 \times 100}{2} = 2,500 \text{ SF} \\
 B &= 150 \times 100 = 15,000 \text{ SF} \\
 C &= \frac{75 \times 100}{2} = 3,750 \text{ SF} \\
 D &= 75 \times 50 = 3,750 \text{ SF} \\
 &= \frac{25,000 \text{ SF} + 3,750 \text{ SF}}{43,560} = .57 \text{ acres}
 \end{aligned}$$

Square footage = 25,000 Acreage = .57

Unit 3, Exercise 3-1 Answers

Locating Townships and Sections

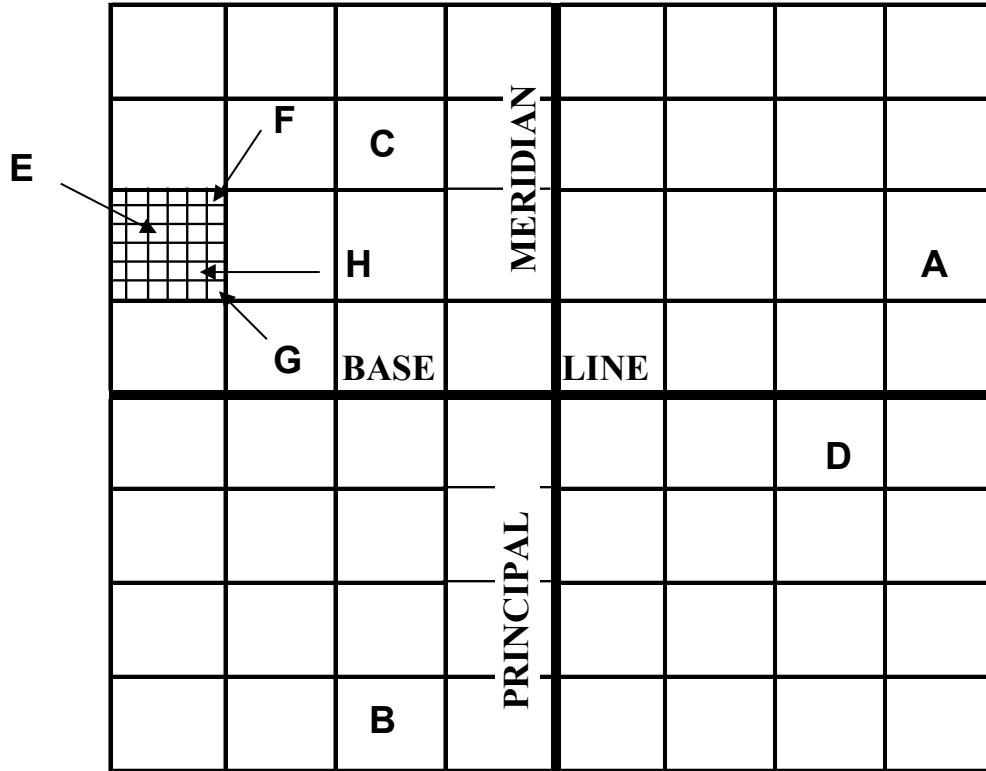

Locate the following and place the appropriate letter in the proper location:

- A.** Township 2 North, Range 4 East
- B.** Township 4 South, Range 2 West
- C.** Township 3 North, Range 2 West
- D.** Township 1 South, Range 3 East
- E.** Section 16, Township 2 North, Range 4 West
- F.** Section 1, Township 2 North, Range 4 West
- G.** Section 36, Township 2 North, Range 4 West
- H.** Section 26, Township 2 North, Range 4 West

Unit 3, Exercise 3-2 Answers

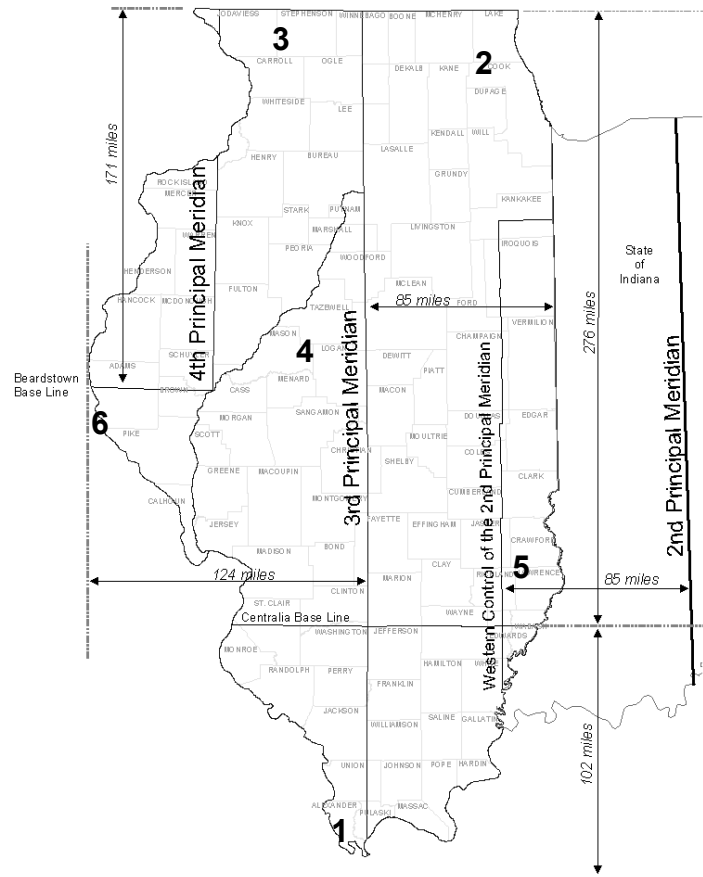

	Location	Township Miles	Range Miles
1.	T12S-R1W, 3rd PM	S / SW	72
2.	T43N-R10E, 3rd PM	NE	258
3.	T27N-R4E, 4 th PM	NW	162
4.	T20N-R3W, 3rd PM	C/ WC	120
5.	T2N-R11W, 2 nd PM	E / SE	12
6.	T3S-R7W, 4 th PM	W / WC	18

Note: Township size is 6 mi. x 6 mi.

Unit 3 Review Answers

1. Sections are numbered in a Serpentine fashion, beginning in the NE corner. There are 36 sections within a township/ range tier.
2. Legal descriptions using the Rectangular Survey System are tied to base lines and meridians. In Illinois, these descriptions are governed by the 2nd, 3rd, or 4th Principal Meridian, and by the Centralia Baseline, or the Beardstown Baseline.
3. The 3rd Principal Meridian virtually cuts Illinois in half. The 2nd Principal Meridian is partially located in Indiana. Both are tied to the Centralia Baseline. The 4th Principal Meridian is located in the northwest portion of the state, and is tied to the Beardstown Baseline.
4. A committee headed by Thomas Jefferson developed a plan for dividing public land into rectangles. This plan was the basis for the Land Ordinance of 1785.
5. A township is a nearly square area of land. Each township is 36 square miles and contains 36 square miles. The first township north of a baseline would be referenced as township 1 N.
6. T44N – R2E, of the 3rd Principal Meridian, is located in the N part of the state of Illinois.
7. Identify the section number marked with an “X” in the township map below.

Cleary Township

			X		

“X” marks Section Number 15

Unit 4, Exercise 4-1 Answers

1. SE $\frac{1}{4}$ of SE $\frac{1}{4}$
40 Acres

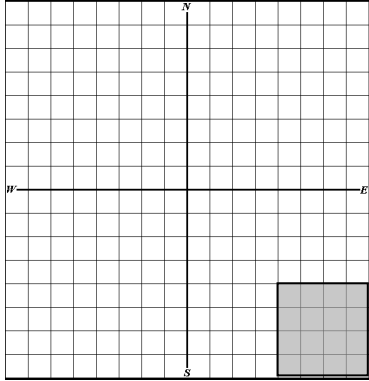

4. E $\frac{1}{2}$ of NW $\frac{1}{4}$ and NW $\frac{1}{4}$ of NW $\frac{1}{4}$
120 Acres

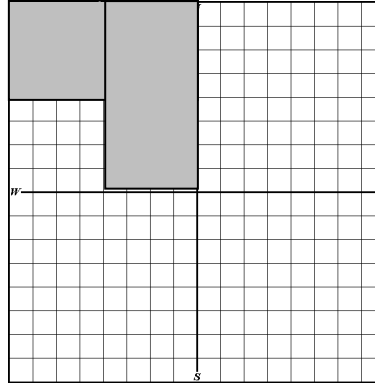

2. S $\frac{1}{2}$ of NW $\frac{1}{4}$
80 Acres

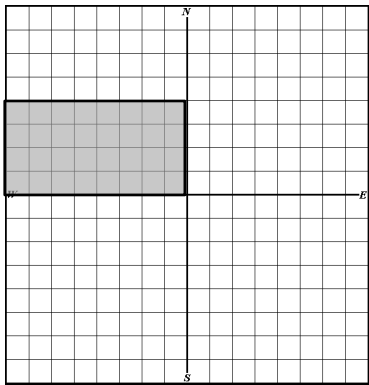

5. SW $\frac{1}{4}$ of SE $\frac{1}{4}$ of SW $\frac{1}{4}$
10 Acres

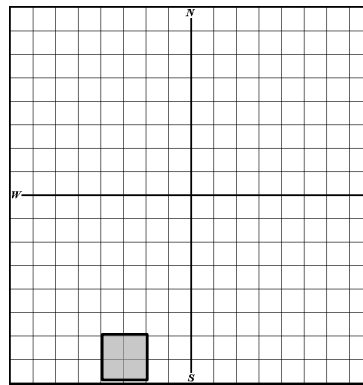

3. N $\frac{1}{2}$ of NE $\frac{1}{4}$ of SE $\frac{1}{4}$
20 Acres

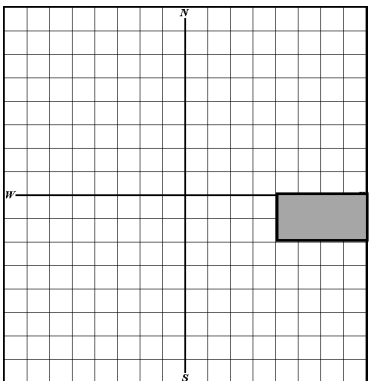

6. NE $\frac{1}{4}$ of NW $\frac{1}{4}$ of SW $\frac{1}{4}$
10 Acres

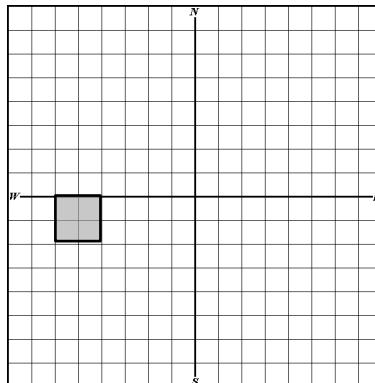

Unit 4, Exercise 4-2 Legal Descriptions with Exceptions Answers

Draw the parcel and calculate the acreage.

The parcel is described as:

The SE $\frac{1}{4}$ of the SE $\frac{1}{4}$ of the NE $\frac{1}{4}$ **and** the NE $\frac{1}{4}$ of the NE $\frac{1}{4}$ of the SE $\frac{1}{4}$ of Section 19, Township 11 South, Range 2W.

($\frac{1}{4} \frac{1}{4} \frac{1}{4} = 10 \text{ acres} + \frac{1}{4} \frac{1}{4} \frac{1}{4} = 10 \text{ acres} = 20 \text{ acres}$).

Except the SW $\frac{1}{4}$ of the NE $\frac{1}{4}$ of the NE $\frac{1}{4}$ of the SE $\frac{1}{4}$ as described above,

($\frac{1}{4} \frac{1}{4} \frac{1}{4} \frac{1}{4} = 2.5 \text{ acres}$. $20 - 2.5 = 17.5 \text{ acres}$)

The entire remaining parcel containing 17.5 acres, more or less

Section 19

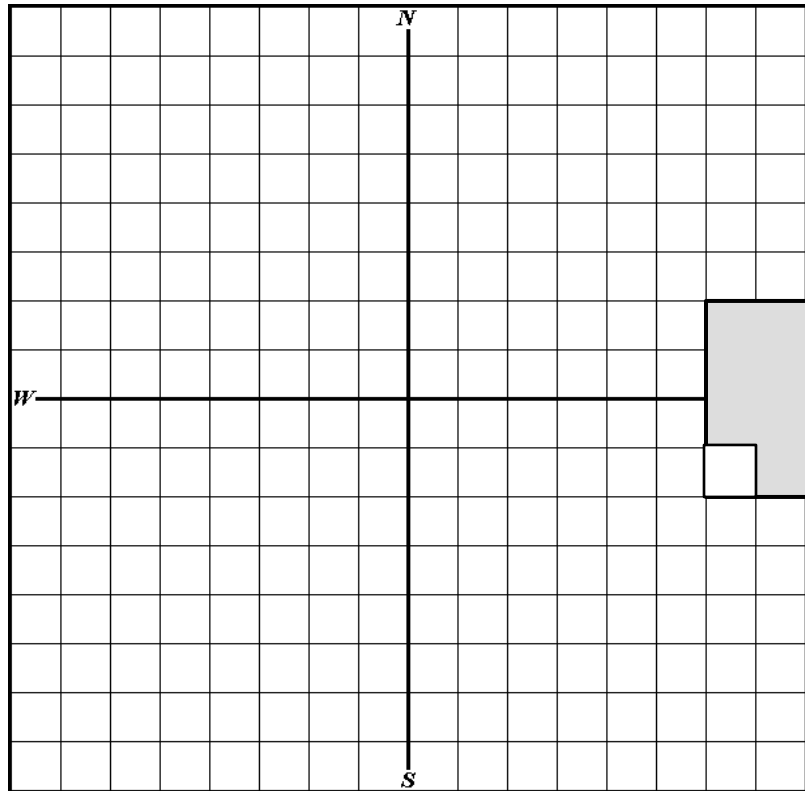

Unit 4, Exercise 4-3 Answers

Please calculate the acreage for the following:

1. The Southeast Quarter of the Southeast Quarter of the Northwest Quarter 10 ;
and the Southwest Quarter of the Southwest Quarter of the Northeast Quarter 10 ;
and the Northwest Quarter of the Northwest Quarter of the Southeast Quarter 10 ;
and the Northeast Quarter of the Northeast Quarter of the Southwest Quarter 10 .
40 acres
2. The East One-half of the Northeast Quarter of the Northeast Quarter of the
Southeast Quarter; and the Southeast Quarter of the Northeast Quarter of the
Southeast Quarter; and the North One-half of the Northeast Quarter of the
Southeast Quarter of the Southeast Quarter.
20 acres
3. The South One-half of the Southwest Quarter of the Southwest Quarter; and the
South One-half of the Southeast Quarter of the Southwest Quarter; and the South
One-half of the Southwest Quarter of the Southeast Quarter; and the Northeast
Quarter of the Southwest Quarter of the Southeast Quarter; and the Northeast
Quarter of the Northwest Quarter of the Southwest Quarter of the Southeast
Quarter; and the Northwest Quarter of the Northwest Quarter of the Southwest
Quarter of the Southeast Quarter.
75 acres
4. The Northeast Quarter of the Northeast Quarter; and the North One-half of the
Northwest Quarter of the Southeast Quarter of the Northeast Quarter; and the
Northeast Quarter of the Northeast Quarter of the Southwest Quarter of the
Northeast Quarter.
47.5 acres
5. The Southwest Quarter of the Southwest Quarter of the Northwest Quarter; and the
Northwest Quarter of the Southwest Quarter of the Northwest Quarter; and the
Southwest Quarter of the Northwest Quarter of the Northwest Quarter.
30 acres
6. The Northwest Quarter of the Northwest Quarter of the Southeast Quarter of the
Northwest Quarter; and the Northeast Quarter of the Northeast Quarter of the
Southwest Quarter of the Northwest Quarter; and the Southeast Quarter of the
Southeast Quarter of the Northwest Quarter of the Northwest Quarter; and the
Southwest Quarter of the Southwest Quarter of the Northeast Quarter of the
Northwest Quarter.
10 acres

Unit 4, Exercise 4-4 Answers

1. The E 80 acres of the N 320 acres
2. The N 40 acres of the E 80 acres of the NW $\frac{1}{4}$
3. The N 40 acres of the SW $\frac{1}{4}$
4. The S 80 acres of the SW $\frac{1}{4}$
5. The E 20 acres of the NW $\frac{1}{4}$ of the NW $\frac{1}{4}$
6. The S 5 acres of the SW $\frac{1}{4}$ of the SW $\frac{1}{4}$ of the SE $\frac{1}{4}$
7. The NE 10 acres of the NW $\frac{1}{4}$ of the SE $\frac{1}{4}$

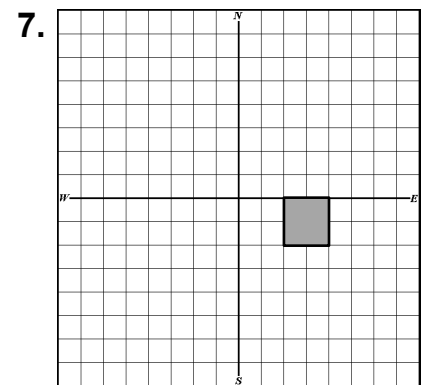
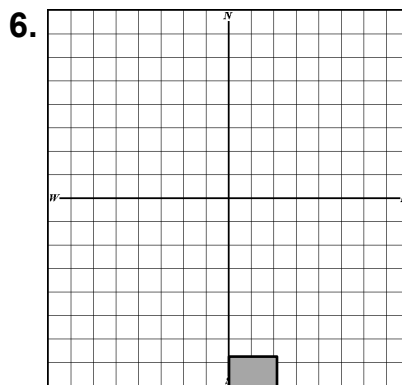
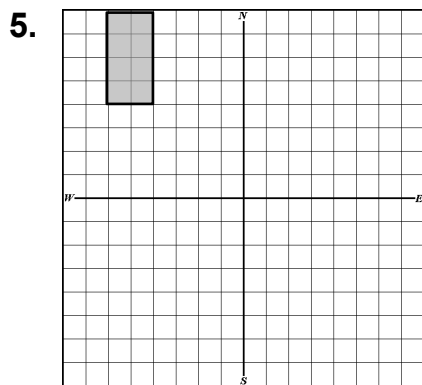
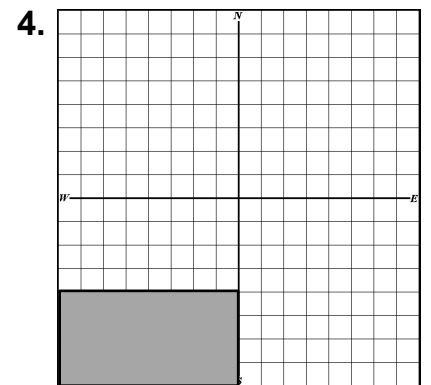
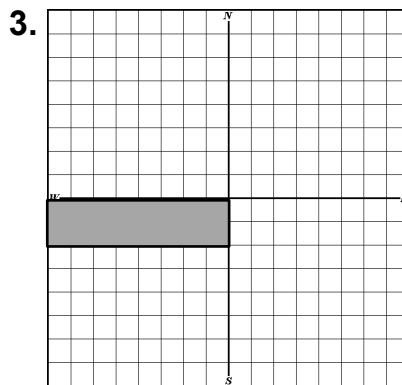
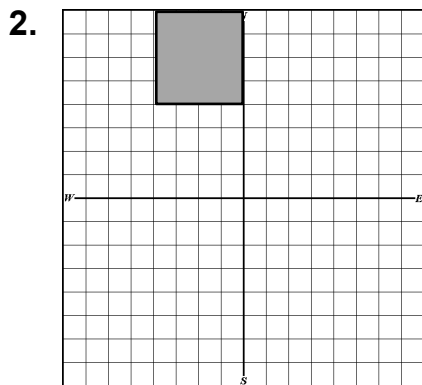
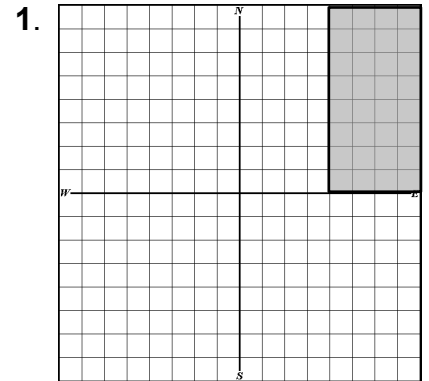

Unit 4, Exercise 4-5 Answers

Draw the following and calculate the correct acreage

1. Beginning at the Southwest corner of Section 12, thence North 2,640 feet; thence East 1,320 feet; thence South 2,640 feet; thence West 1,320 feet to the point of beginning.

Section 12

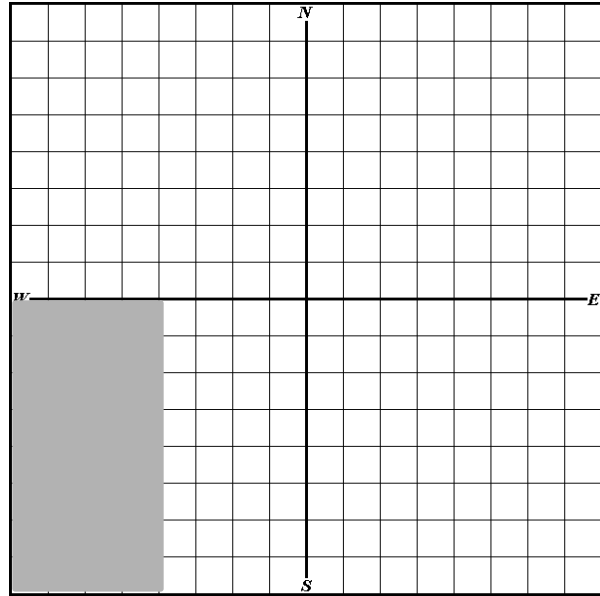

Acreage is calculated by multiplying
 $2,640 \times 1,320 = 3,484,800 / 43,560 =$

80 Acres

2. Beginning at the Northeast corner of Section 32, thence West 1,320 feet; thence South 3,960 feet; thence East 990 feet; thence North 660 feet; thence East 330 feet; thence North 3,300 feet to the point of beginning.

Section 32

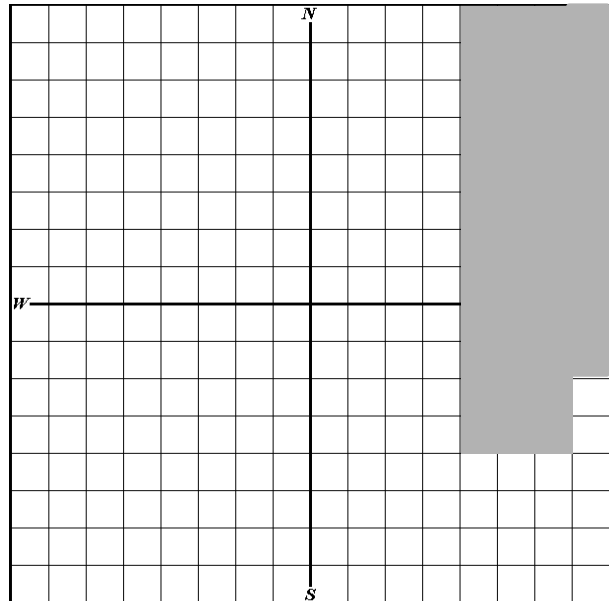

Acreage is calculated by multiplying
 $1,320 \times 3,960 = 5,227,200$ and
then subtracting $660 \times 330 = 217,800$

$$5,227,200 - 217,800 = 5,009,400$$

$$5,009,400 / 43,560 = \mathbf{\underline{115 Acres}}$$

Unit 4, Exercise 4-6

1. The N 10 chains off of the NW $\frac{1}{4}$

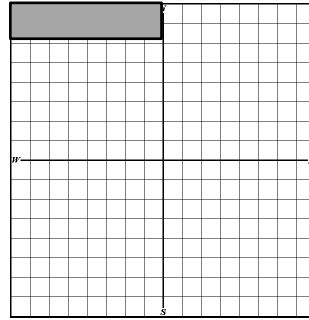

2. The W 330 feet off of the SW $\frac{1}{4}$ of the SE $\frac{1}{4}$

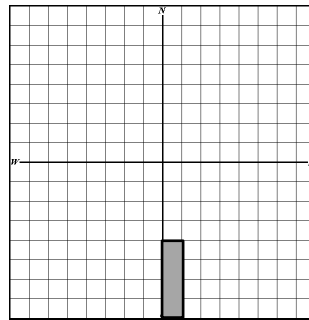

3. 82.5 ft. off of the S side of the NW $\frac{1}{4}$

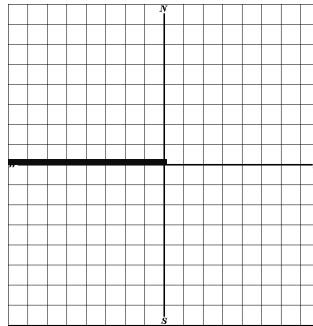

4. The East 330 ft. off of the E $\frac{1}{2}$
of the NW $\frac{1}{4}$ of the NE $\frac{1}{4}$

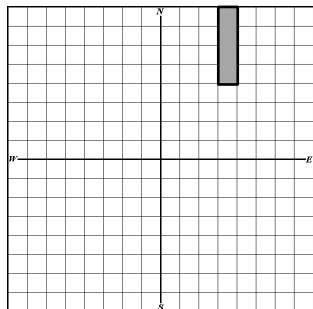

Unit 4, Exercise 4-7 Answers

In this exercise, you will measure the shapes in linear feet and then convert them into acreage. In addition, you will write the legal description describing the parcel.

Figure 1.

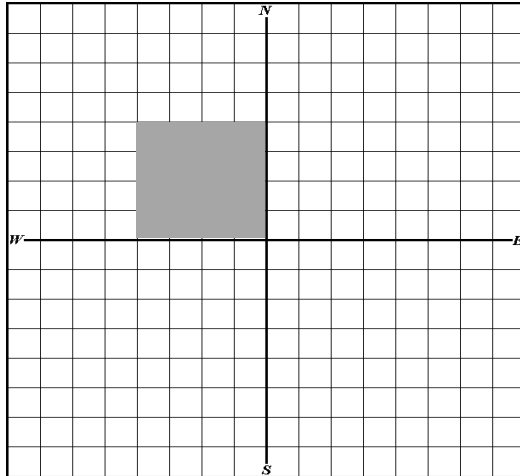

Linear measurements 1,320 feet X 1,320 feet.

Acreage calculation $1,320 \times 1,320 = 1,742,400 \text{ SF} / 43,560 = 40 \text{ acres}$

Legal Description "Section 14, Township 9 North, Range 1 E of the 3rd Principal Meridian, **The South 1,320 feet of the NW ¼ except the West 1,320 feet of the NW ¼.** *There are several ways to describe this parcel.*

Figure 2.

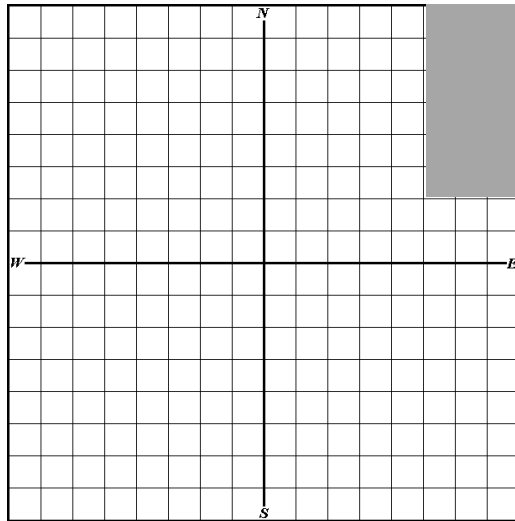

Linear measurements 990 feet X 1,980 feet.

Acreage calculation $990 \times 1,980 = 1,960,200 \text{ SF} / 43,560 \text{ SF} = 45 \text{ acres}$

Legal Description "Section 14, Township 9 North, Range 1 E of the 3rd Principal Meridian, **The East 990 feet of the NE ¼ excepting the South 660 feet of the NE ¼.**"

Unit 4 Review Answers

1. Answers for questions A through F are on the section grid on **the following page**.

A. The NW $\frac{1}{4}$

B. The SE $\frac{1}{4}$ of the SE $\frac{1}{4}$

C. The S 165 feet off of the SW $\frac{1}{4}$

D. 82.5 ft. off of the E side of the NE $\frac{1}{4}$

E. The East 40 acres of the W 80 acres of the NE $\frac{1}{4}$

F. The North 10 chains off of the SE $\frac{1}{4}$

2. Calculate the acreage for the following.

a. The Northeast Quarter of the Northwest Quarter = 40 acres.

b. The SE $\frac{1}{4}$ of the SE $\frac{1}{4}$ of the SE $\frac{1}{4}$ = 10 acres.

c. The East $\frac{1}{2}$ of the Northwest Quarter of the Northeast Quarter = 20 acres.

3. To locate a parcel using a metes and bounds description, first read the land description portion of the legal description backwards, and then read the metes and bounds portion of the description in the order written.

4. Read all legal descriptions not written in metes and bounds backwards.

D. 82.5 feet off of the E side of the NE ¼ 5 acres

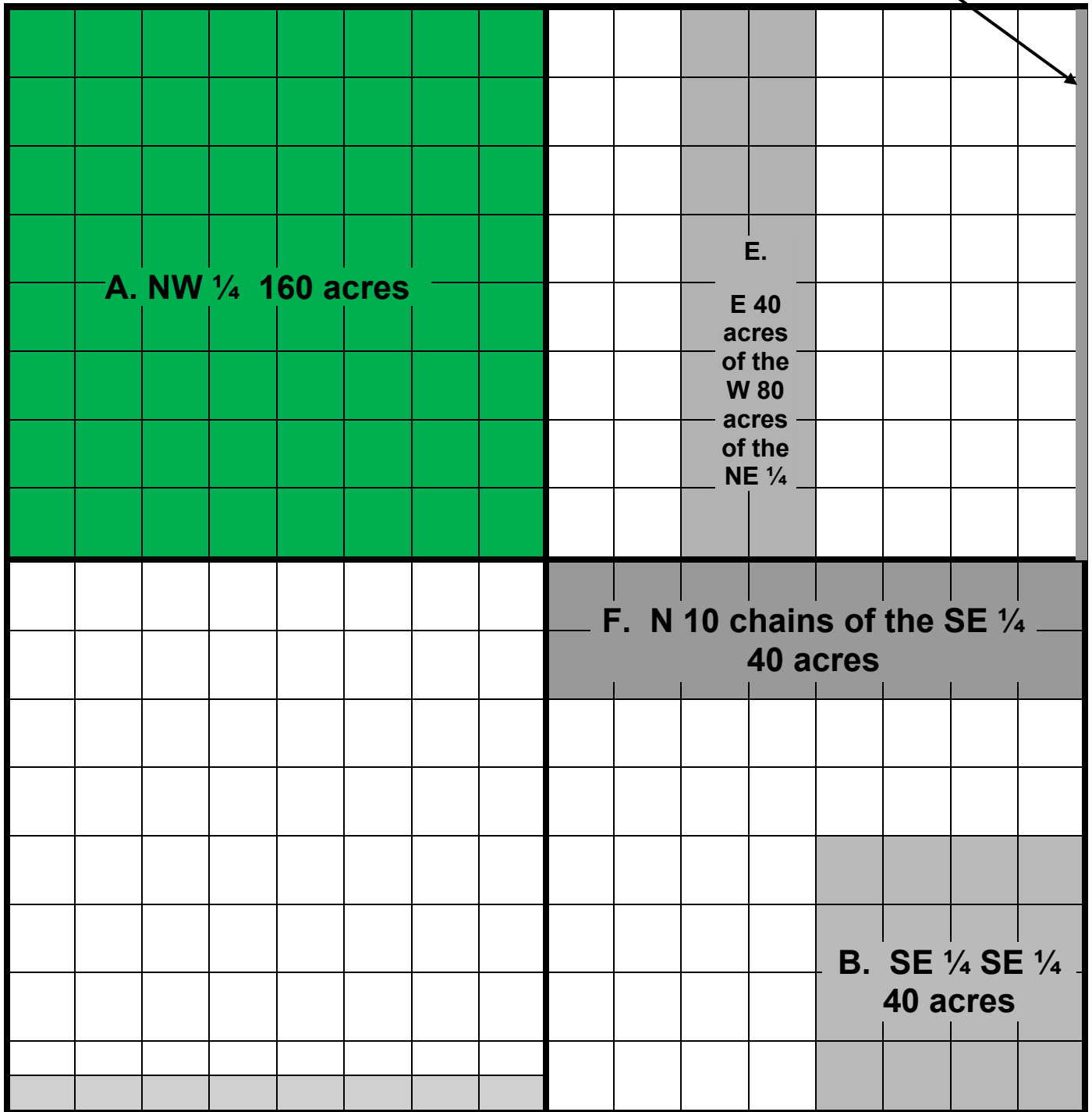

C. S 165 feet of the SW ¼ 10 acres

5. Write the legal description and calculate acreage below each section map:

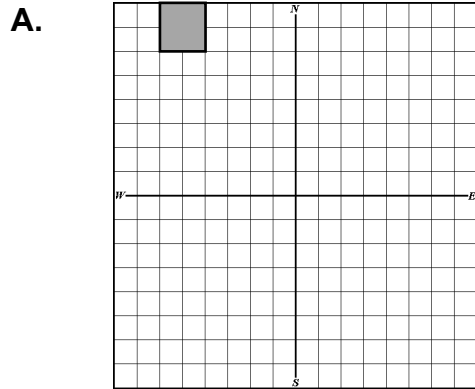

NE 1/4 NW 1/4 NW 1/4

10 acres

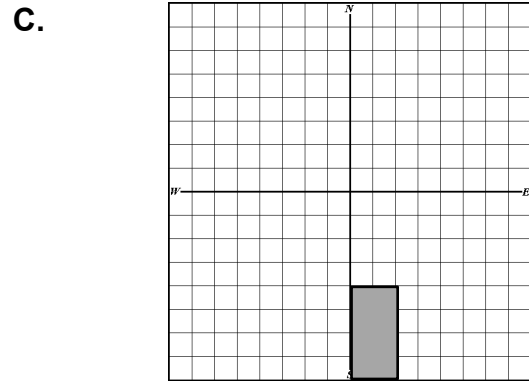

W 1/2 SW 1/4 SE 1/4

20 acres

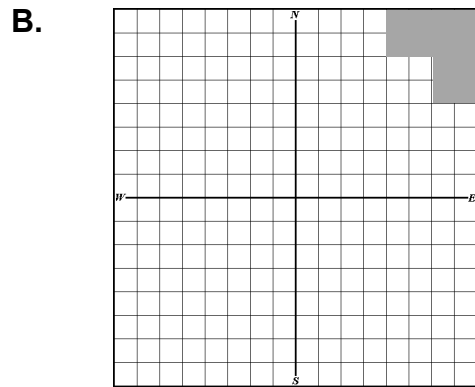

N 1/2 NE 1/4 NE 1/4 and

SE 1/4 NE 1/4 NE 1/4

30 acres

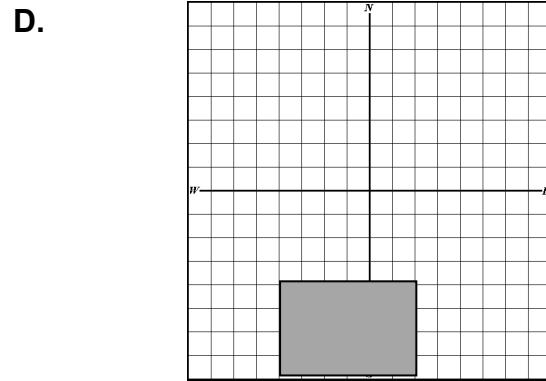

SE 1/4 SW 1/4 and the

W 1/2 SW 1/4 SE 1/4

60 acres

6. Compute the acreage for the following parcel of land.

A part of the Southwest Quarter of Section 30, Township 11 South Range 1 East, of the Third Principal Meridian, described as follows: Commencing at the N.W. corner of the Southwest Quarter, thence running East 18 chains, thence running South 8 chains, thence East 5 chains, thence South 4 chains, thence West 23 chains, thence North 12 chains to the point of beginning.

Convert First! 1 chain = 66 feet.

- 18 x 66' = 1,188'
- 8 x 66' = 528'
- 5 x 66' = 330'
- 4 x 66' = 264'
- 23 x 66' = 1,518'
- 12 x 66' = 792'

$$1,188' \times 792' = 940,896 + 330' \times 264' = 87,120$$

$$1,028,016 / 43,560 = \underline{23.6 \text{ acres}}$$

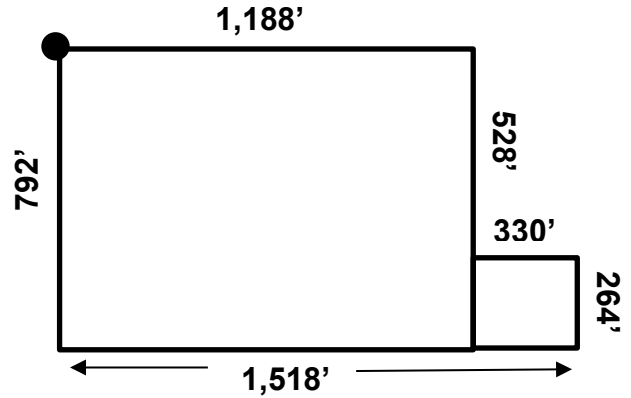

Unit 5, Exercise 5-1 Answers

Map Scale	Ground Distance	Length of Line on Map
1. <u>1:100</u>	330 ft.	<u>3.3"</u>
2. <u>1:400</u>	2,640 ft.	<u>6.6"</u>
3. <u>1:600</u>	5,280 ft.	<u>8.8"</u>
4. <u>1:660</u>	5,280 ft.	<u>8.0"</u>
5. <u>1:660</u>	1,320 ft.	<u>2.0"</u>
6. <u>1:200</u>	675 ft.	<u>3.4"</u>

Unit 5, Exercise 5-2 Answers

1. Beginning at a point, thence N 80° E, 400'; thence S 30° E, 300'; thence S 80° W, 300'; thence N 46° W, 350', to the point of beginning.

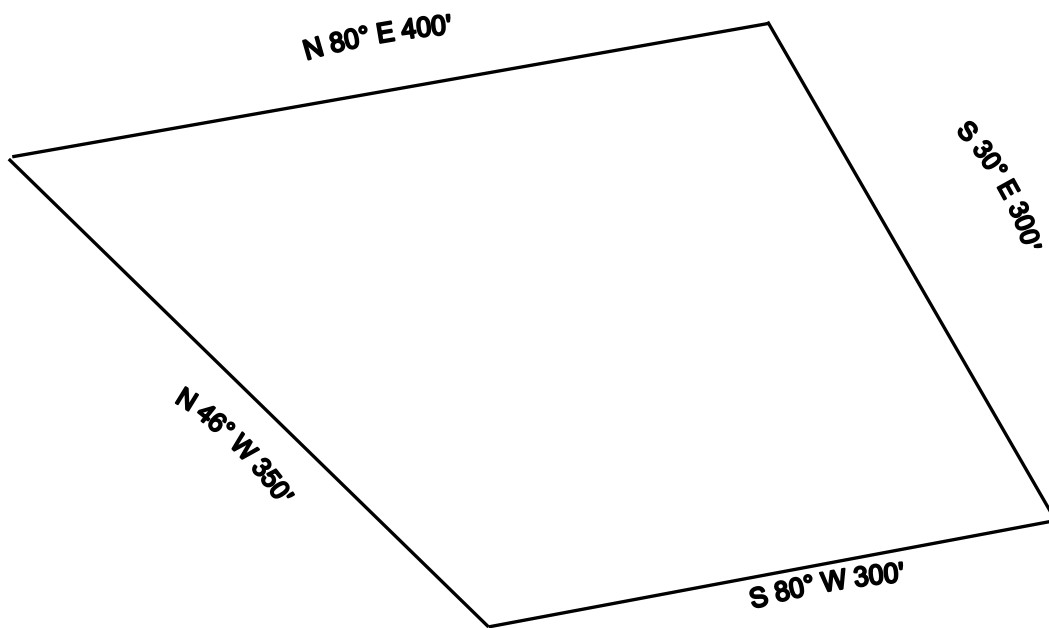

Unit 5, Exercise 5-2 Answers (continued)

2. Beginning at a point, thence N 82° E, 450'; thence S 10° W, 200'; thence S 82° W, 250'; thence N 43° W, 230' to the point of beginning.

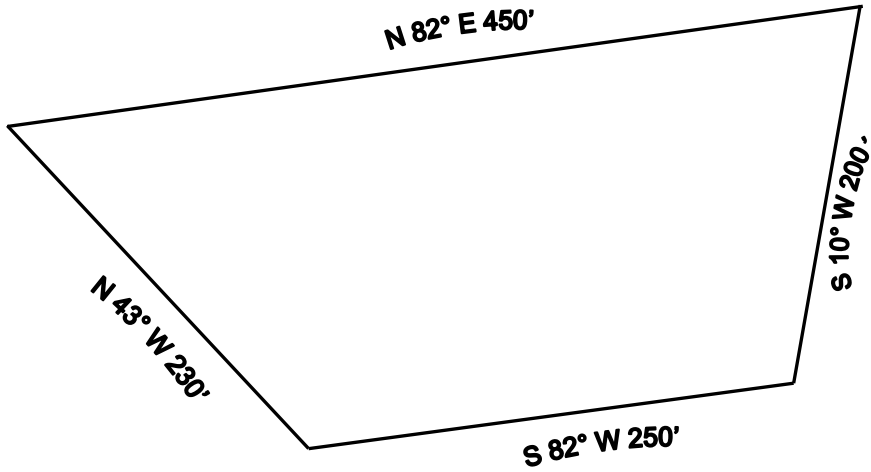

3. Beginning at a point, thence S 77° E, 500' to a point; thence S 40° W, 250' to a point; thence N 65° W, 250' to a point; thence N 29° W, 220' to the point of beginning.

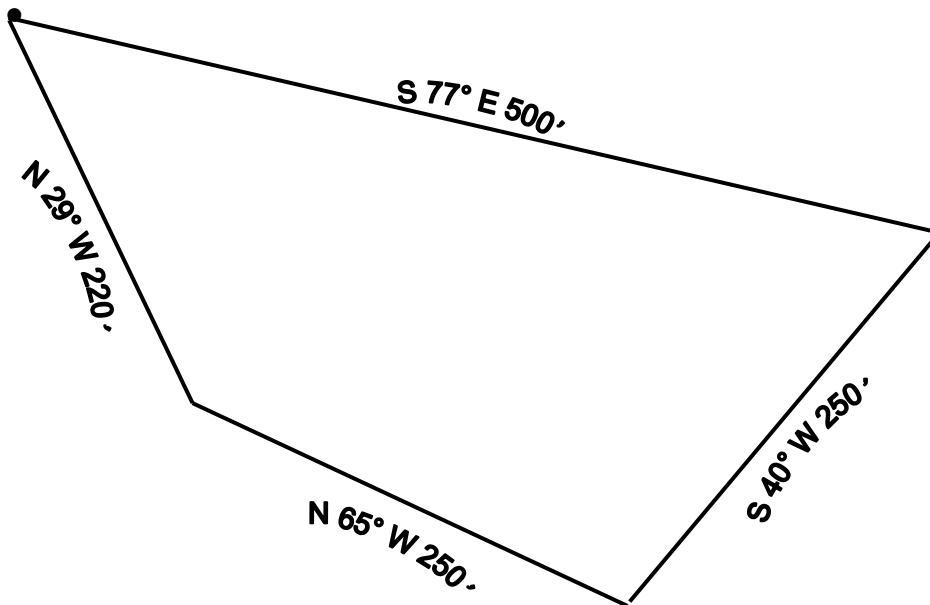

4. Beginning at a point, thence S 78°E, 425' to a point; thence S 15° E, 100' to a point; thence S 85°W 550' to a point; thence N 25°E, 260' to the point of beginning.

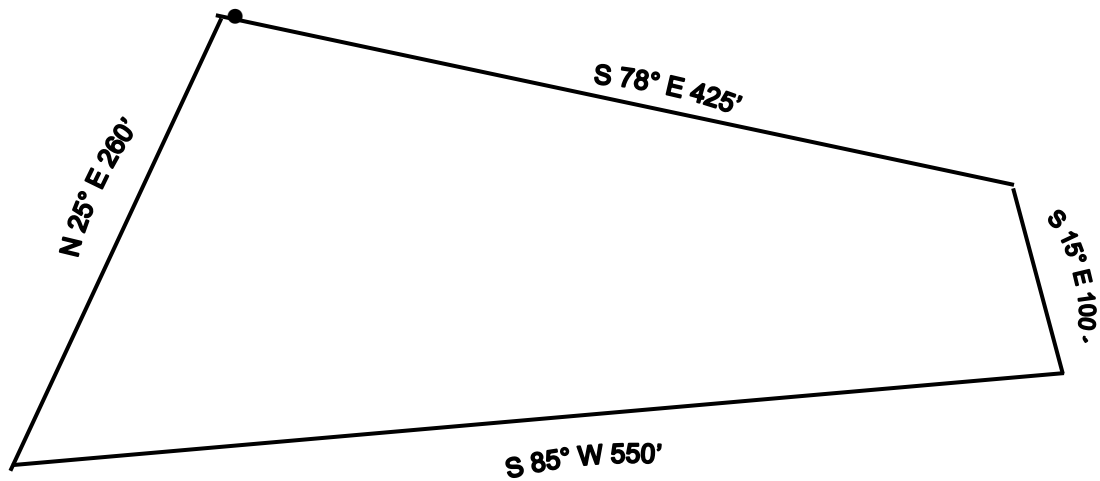

5. Beginning at a point, thence N 23°E, 175' to a point; thence N 68°E, 350' to a point; thence N 88°E, 150' to a point; thence S 32°E, 250' to a point; thence S 53°W, 150' to a point; thence N 67°W, 150' to a point; thence S 80°W, 420' to the point of beginning.

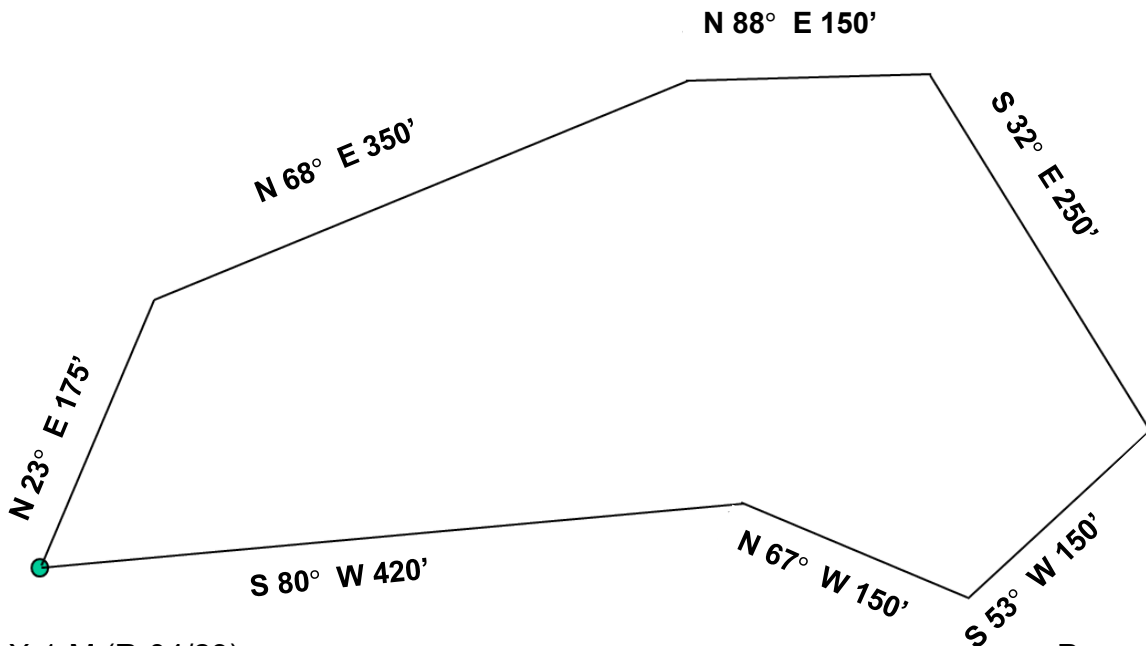

Extra Practice for Over-Achievers!

Use the Blank Page following to complete the drawing

6. Using a scale of 1" = 200', please draw the following legal description and calculate the total acreage.

Note that in this legal description “Commencing at” leads you to the point of beginning.

Commencing at the Northwest corner of Section 6, Township 11 South, Range 2 West of the 3rd Principal Meridian, thence East along the Section line 460 feet to the **point of beginning**. Thence continue East 90°, 200 feet to a point; thence S 0°, 45 feet to a point; thence East 90°, 50 feet to a point; thence S 0°, 40 feet to a point; thence W 90°, 110 feet to a point thence S 0°, 815 feet; thence N 38° W, 105 feet to a point; thence W 90°, 40 feet to a point; thence S 0°, 30 feet to a point; thence W 90°, 35 feet to a point; thence S 0°, 50 feet to a point; thence W 90°, 150 feet to a point; thence N 0°, 180 feet to a point; S 40° W, 235 feet to a point; thence W 90°, 45 feet to a point; thence N 0°, 470 feet to a point; thence E 90°, 195 feet to a point; thence N 58° W, 225 feet to a point; thence N 0°, 80 feet to a point; thence E 90°, 195 feet to a point; thence N 0°, 145 feet to a point; thence N 70° E, 160 feet to a point; thence N 0°, 45 feet to the point of beginning

Extra Practice for Over-Achievers!

6.

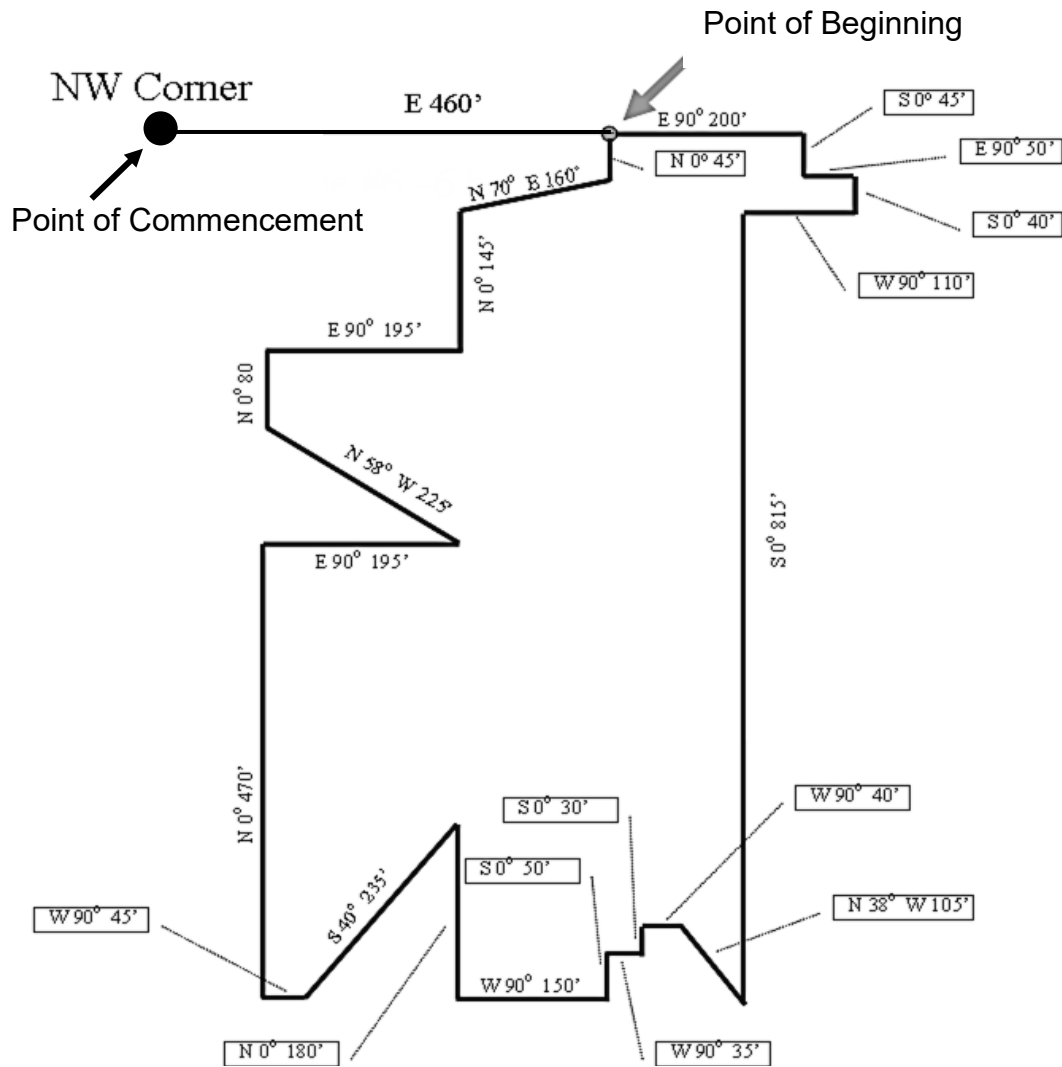

Please note measurements may not be exactly on scale to 1:200 due to converting to pdf format, copying, etc.

Your drawing should match the overall shape and “close”.

Unit 5 Review Answer 1 and Drawing

Beginning at the Northwest corner of the Southwest Quarter of Section 12, Township 8 North, Range 3 West of the Third Principal Meridian, thence East 2 Furlongs; thence South 6 rods; thence East 2 chains, 1 rod; thence South 26 degrees East 990 feet; thence West 2 furlongs, 34 rods; thence North 1000 feet to the point of beginning, containing 37.64 acres, more or less.

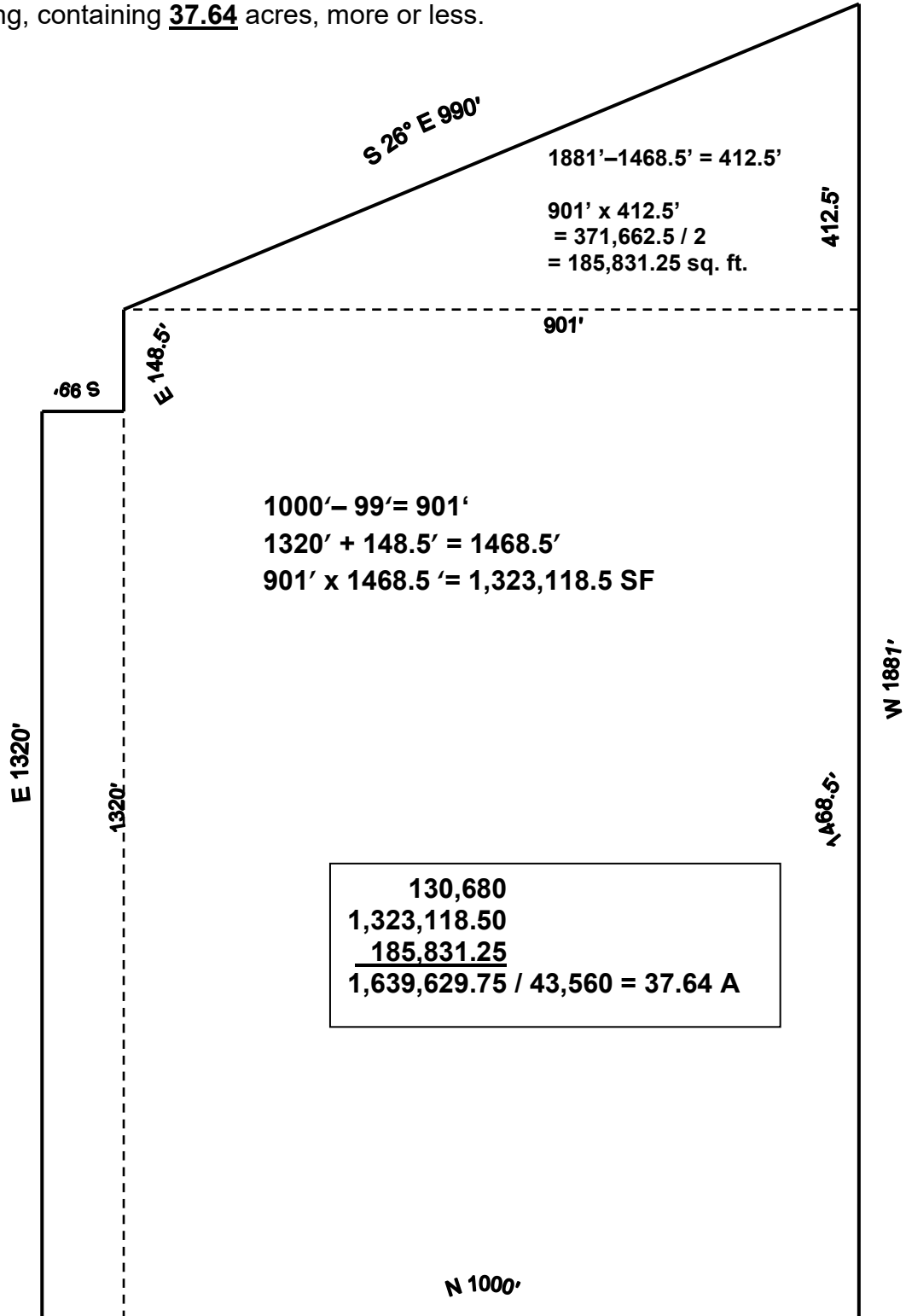

Unit 5, Review Answer 2 and Drawing

The Harper Parcel

Beginning at the SW corner of the SE $\frac{1}{4}$ of the NE $\frac{1}{4}$ of Section 27, Township 12 South, Range 2 West of the 3rd PM, thence N 275 feet to a white pine tree, thence East 38 feet to a stone, thence South 50 feet to a fence post at the corner of the Brown farm, thence E 200 feet to a maple tree 2 inches in diameter, thence S 28° E 250 feet to a Wahoo, thence W 350 feet to the point of beginning, containing 1.56 acres, more or less.

$$38 \times 50 = 1900$$

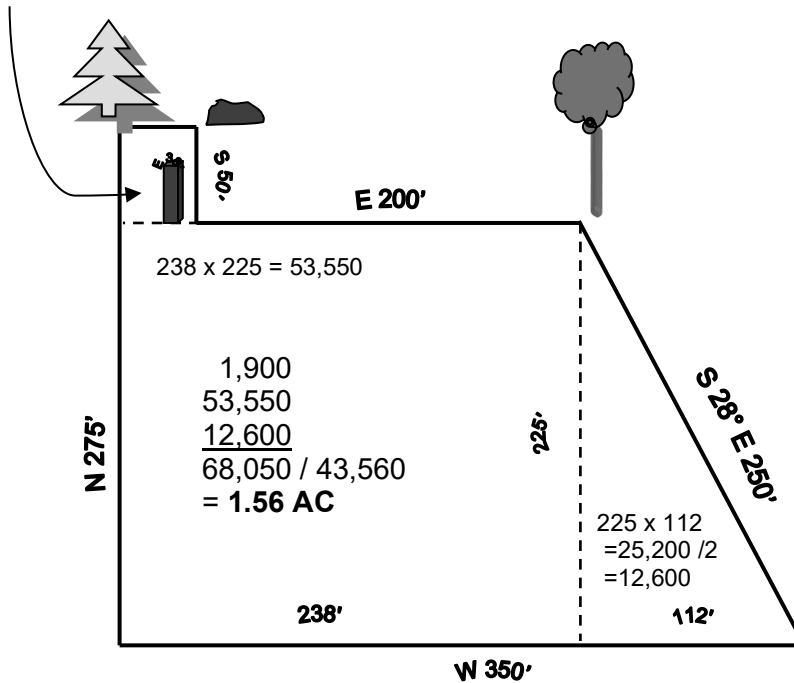

WAHOO!!!



Unit 6, Exercise 6-1 Answer and Drawing

Transaction "A":

Legal Description: Section 26, Twp. 4S, Range 3W, 3rd PM (640 acres)

(A) 01-26 - 100 - 001 – 0021 (Heart Tract)

Transaction "B":

Legal Description: The SW $\frac{1}{4}$ of Section 26, Twp. 4S, Range 3W, 3rd PM (160 acres)

01 - 26 - 100 - 002 – 0021 (Heart Tract)

(B) 01 - 26 - 300 - 001 – 0021 (Johnson Tract)

Transaction "C":

Legal Description: The NE $\frac{1}{4}$ of the NE $\frac{1}{4}$ of Section 26, Twp. 4S, Range 3W, 3rd PM (40 acres)

01 - 26 - 100 - 003 – 0021 (Heart Tract)

(C) 01 - 26 - 200 - 001 – 0021 (Freeman Tract)

Transaction "D":

Legal Description: The NW $\frac{1}{4}$ of the NW $\frac{1}{4}$ of Section 26, Twp. 4S, Range 3W, 3rd PM (40 acres)

01 - 26 - 100 - 004 – 0021 (Heart Tract)

(D) 01 - 26 - 100 - 005 - 0021 (Carter Tract)

Transaction "E":

Legal Description: The SW $\frac{1}{4}$ of the NW $\frac{1}{4}$ of Section 26, Twp. 4S Range 3W, 3rd PM (40 Acres)

01 - 26 - 100 - 006 – 0021 (Heart Tract)

(E) 01 - 26 - 100 - 007 – 0021 (Jones Tract)

Transaction "F":

Legal Description: The NE ¼ of the NW ¼ and the SE ¼ of the NW ¼ of Section 26,
Twp. 4S, Range 3W, 3rd PM (80 acres)

01 - 26 - 200 - 002 - 0021 (Heart Tract)

(F) **01 - 26 - 100 - 008 - 0021** (Weber Tract)

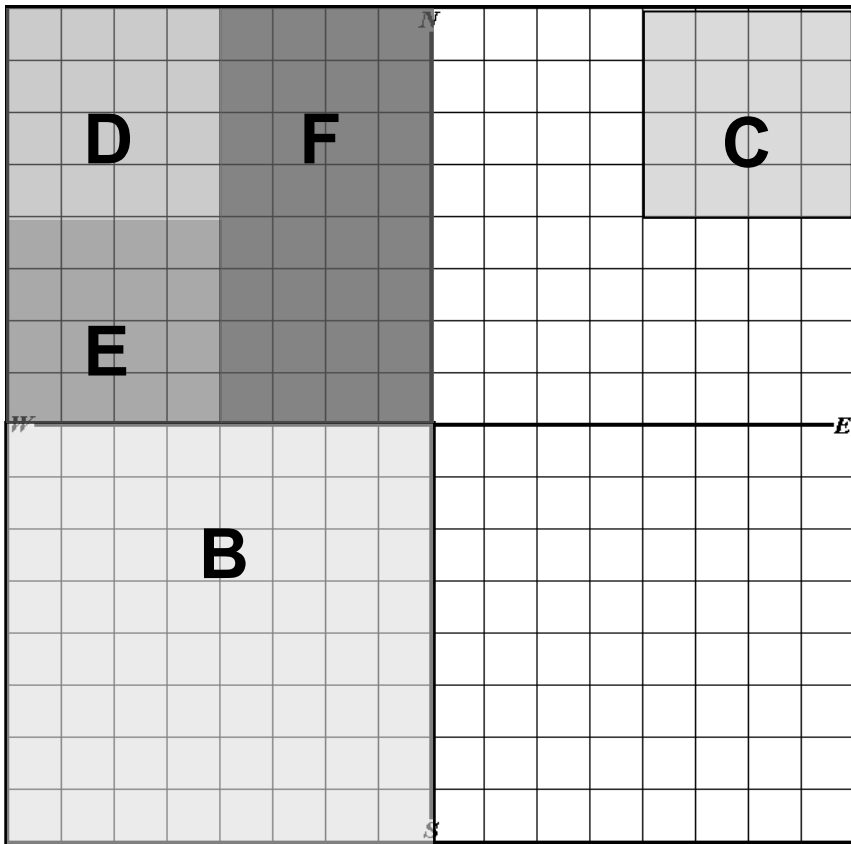

Unit 6 Exercise 6-2 Answers

Real Estate Transaction "A" containing 640 acres, more or less.

PIN: 08-36-100-001-0021 (Joseph tract)

Real Estate Transaction "B" containing 80 acres, more or less

PIN : 08-36-100-002-0021 (Joseph tract)

PIN: 08-36-100-003-0021 (Harris tract)

Real Estate Transaction "C" containing 160 acres, more or less.

PIN : 08-36-100-004-0021 (Joseph tract)

PIN: 08-36-300-001-0021 (Davis tract)

Real Estate Transaction "D" containing 80 acres, more or less.

PIN : 08-36-200-001-0021 (Joseph tract)

PIN: 08-36-100-005-0021 (Charles tract)

Real Estate Transaction "E" containing 10 acres, more or less.

PIN : 08-36-200-002-0021 (Joseph tract)

PIN: 08-36-400-001-0021 (Hardy tract)

How many acres does Joseph own now? 310 acres.

Unit 6, Exercise 6-2 Answers and Drawing

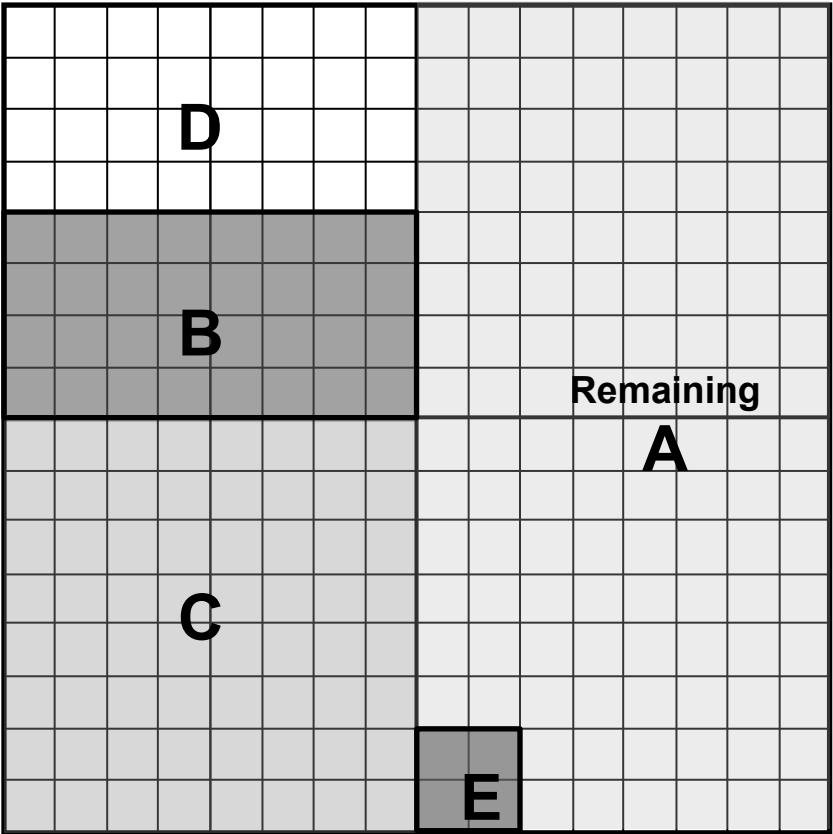

Unit 6, Review Answers

Draw the property described on the following sheet and record the PINS for each property and calculate the acreage. **Scale 1:660**

Mikey Moose owns the property described as all of Section 16.

The PIN is 01-16-100-001-0020

Mr. Moose decides to convey the following to Duffy Duck:

(A) Moose to Duck

Legal...**SE $\frac{1}{4}$ of the NE $\frac{1}{4}$ of the SE $\frac{1}{4}$ of the NW $\frac{1}{4}$**
2.5 Acres, more or less.

Moose PIN 01-16-100-002-0020

Duck PIN 01-16-100-003-0020

(B) Moose to Leaphorn

Legal...**SE $\frac{1}{4}$ of the NE $\frac{1}{4}$ of the NE $\frac{1}{4}$ of the NE $\frac{1}{4}$**

2.5 Acres, more or less

Moose PIN 01-16-100-004-0020

Leaphorn PIN 01-16-200-001-0020

(C) Legal.... **S $\frac{1}{2}$ of the NE $\frac{1}{4}$ and the NW $\frac{1}{4}$ of the NE $\frac{1}{4}$ of the SE $\frac{1}{4}$.**

90 Acres, more or less

Moose PIN 01-16-100-005-0020

Coyote PIN 01-16-200-002-0020

(D) Legal.... **From the point of the SW corner of Section 16, traverse East 1155 feet to the POB. Thence North 330', thence E 165 feet, thence South 330 feet, thence West 165 feet to the point of beginning.**

1.25 Acres, more or less.

Moose PIN 01-16-100-006-0020

Byrd PIN 01-16-300-001-0020

Unit 6, Review Drawing

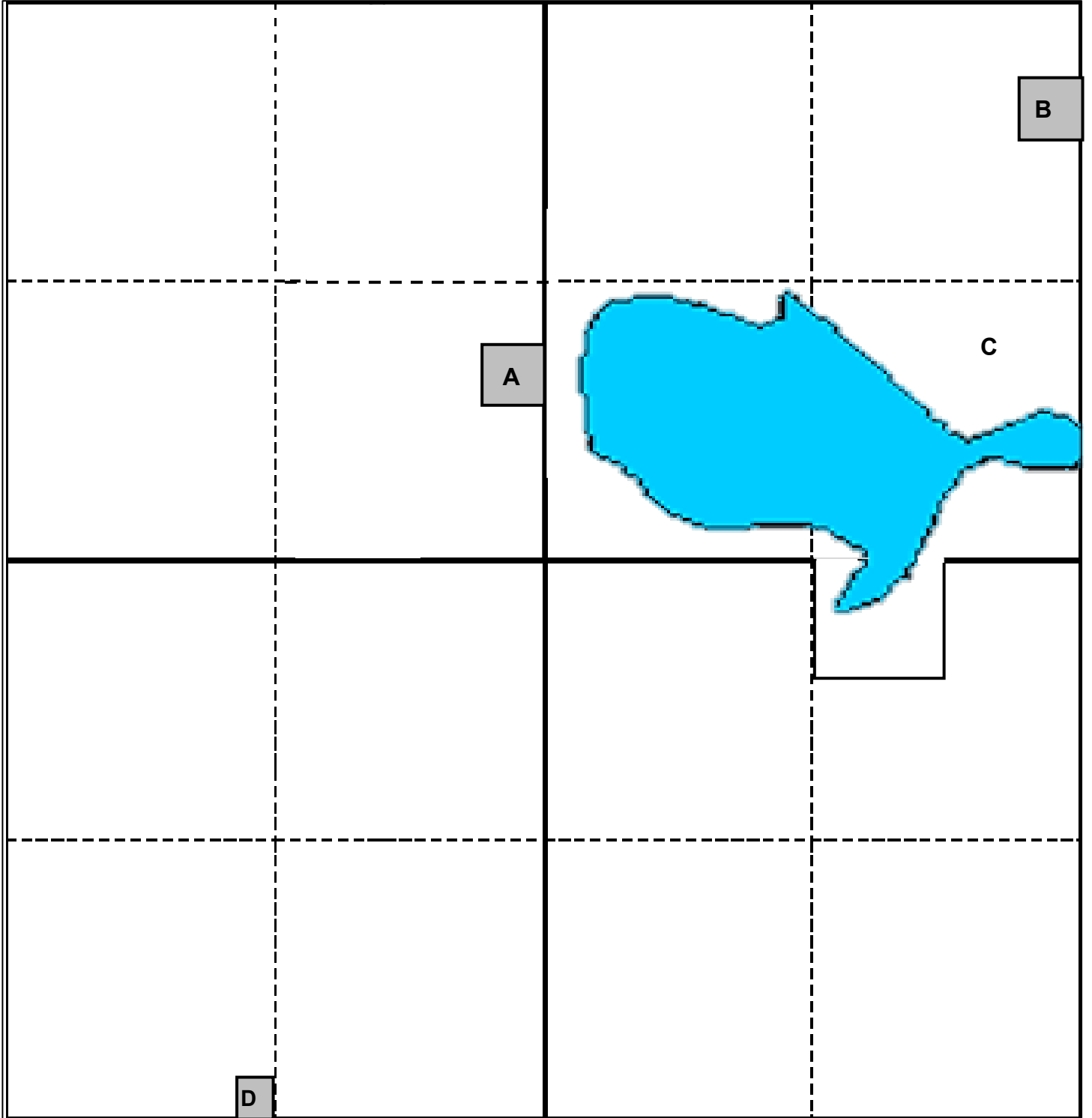

Unit 7 Review Answers

1. Define GIS.

Geographic Information System – A system developed for spatial analysis needs such as planning natural resources and land records management.

2. What are three benefits of GIS for assessors?

Reduce time and expense of field assessments; Increase revenue by discovering previously undetected improvements; Identify changes more quickly; Provide access to gated, uninhabited and hard-to reach structures; Share costs with other users; Improve communications with property owners; Improve ability to “travel” between farms without risk of spreading bacteria or disease; Efficiently maintain maps.

3. Define GIS Vector data.

Basic points, lines, and polygons that make up features of a map.
